



taranto



LINEA PESADA **2018**



En este Catalogo usted puede encontrar todos los artículos para las aplicaciones en las líneas vehicular, pesada y asiáticas.
Para facilitar su búsqueda Taranto le ofrece dos metodologías distintas de búsqueda:
In this Catalog you can find all the articles for the applications in light lines, heavy duty lines and asiatic models.
To facilitar your search Taranto offers two different methodologies:

1 INDICE ORDENADO POR REFERENCIA TARANTO

Index ordered by Taranto references.

► SIMBOLOS - Symbols



Catálogo Vehicular
Automotive Catalog



Catálogo Línea Asiática
Asiatic Catalog



Catálogo Línea Pesada
Heavy Duty Catalog

TABLA DE REFERENCIAS / REFERENCE TABLE

Ref. TARANTO	Pág. C. PESADO	Ref. TARANTO	Pág. C. PESADO	Ref. TARANTO	Pág. C. PESADO	Ref. TARANTO	Pág. C. PESADO	Ref. TARANTO	Pág. C. PESADO	Ref. TARANTO	Pág. C. PESADO
210000	05	350200	85	400800	82	423000	01	700400	43	850100	74
210100	06	350300	86	400900	128	423100	02	700500	44	850200	75
210200	07	350400	88	401000	129	423200	03	700600	45	850300	76
210300	08	350600	90	401100	130	440000	119	700700	46	850400	77
210400	11	350800	92	401500	131	440100	120	700800	47	850500	78
210500	12	350900	93	401600	132	650000	23	700900	48	850600	79
210600	13	351000	95	401700	134	650100	24	710100	49	850700	80
210700	14	352000	96	410000	136	650200	25	710200	50	870000	15
210800	09	352200	97	410100	137	650300	26	750000	69	870100	17
310400	107	360000	99	410200	138	650400	27	750100	70	870200	19
310500	109	360100	100	410300	139	650500	28	750200	71	870500	21
320400	111	360200	101	410400	140	650600	29	800000	51	870600	22
320800	112	360300	102	410500	141	650700	30	800100	53	880000	159
330000	65	360400	103	410600	142	650800	31	800200	54	880100	161
330100	66	360800	105	410700	143	650900	32	800300	55	880200	163
330200	67	400000	121	410800	144	651000	33	800500	57	880300	165
330400	113	400100	122	410900	145	660000	35	800600	59	880400	167
330700	114	400200	123	420000	146	660100	36	800800	61	880500	169
330800	116	400300	124	420100	147	660200	37	800900	62	880600	171
331200	117	400400	125	420200	148	700000	39	801000	64	880700	173
331300	118	400500	126	420400	149	700100	40	810000	153	880800	175
350000	83	400600	127	420600	150	700200	41	810100	154	910900	157
350100	84	400700	81	422000	151	700300	42	850000	73		

2 INDICE ORDENADOS POR CM³

Index ordered by cm³.

MOTORES ORDENADOS POR CM³ - ENGINES ARRANGED BY CM³

AGCO/SISU

Ref.	Modelo/Model	CM ³	Motor/Engine		
423000	A65/A75, 305/355/365/405/455/465/555/565/600/700, Case-IH CS 68/75	DIESEL 3300cc.	320D/DS Agco Sisu Power 33/69HP Ø108		01
423100	A950/A990/BM100/BM110 (4x2, 4x4) - MF4292, MF4297	DIESEL 4400cc.	420D/DS Agco Sisu Power 106/129HP Ø108		02
423200	8000 - Case-IH CS/CVX 120/130/150 - CVX 1135/1145/1155/1170/1190	DIESEL 6600cc.	620D/DS Agco Sisu Power 147/189 Ø108		03

AGRALE

330800	Camión TX 1600 1983/...	DIESEL 2942cc.	D229-3 72HP Ø102		116
330400	7000/7500/8500	DIESEL 4300cc.	4.10 X10 90HP - 4.10T/TCA 133/167HP Ø103		113
331200	8500/9200	DIESEL 4800cc.	4.12TCE Commom Rail 150/180HP Ø105		117

BEDFORD

210800	C14 - J17/J27/J37 1962/64	DIESEL 3285cc.	200D 62HP Ø98.3		09
210200	C50 Turbo 1971/79	DIESEL 4927cc.	300DX 97HP Ø98.3		07
210300	J6 1956/61	DIESEL 4927cc.	300D 97HP Ø98.3		08
210000	J6 1961/71	DIESEL 4927cc.	300D 97HP Ø98.3		05
210100	350H, C60, 714 1971/79	DIESEL 5755cc.	350D - CD600 137HP Ø106.36		06



CATERPILLAR					
Ref.	Modelo/Model		Cm³	Motor/Engine	
960532	Caterpillar Motoniveladora	DIESEL		D339 - D17 - 2 cilindros	XXI
960534	Caterpillar	DIESEL		D318 - 12 70 D - 6 cilindros	XXI
960535	Caterpillar	DIESEL		D8 14A - 46A D342 - 3 cilindros	XXI
960541	Caterpillar	DIESEL		9 44/43 A950 D330 - 4 cilindros	XXI
960542	Caterpillar	DIESEL		D315 112 34 - 4 cilindros	XXI
960543	Caterpillar	DIESEL		922 59A D6 - 4 cilindros	XXI
960544	Caterpillar	DIESEL		12 99E 966 - 334 - 6 cilindros	XXI
960547	Caterpillar	DIESEL		D9 D353 - 3 cilindros	XXI
960548	Caterpillar Motoniveladora	DIESEL	6969cc.	3304 Ø120.65 - 4 cilindros	XXI
960549	Caterpillar Motoniveladora	DIESEL	10453cc.	3306 Ø120.65 - 6 cilindros	XXI
960550	Caterpillar	DIESEL		3054 - 4 cilindros	XXI
960551	Caterpillar	DIESEL		3056 - 6 cilindros	XXII
GM - CHEVROLET					
210800	C14/J17/J27/J37 1962/64	DIESEL	3285cc.	200D 62HP Ø98.3	09
401000	D20	DIESEL	3860cc.	Q20B4 lny. Directa 70HP Ø98.4	323 129
410600	D10/20/40 Aspirado Turbo	DIESEL	3860cc.	Q20B4- 4.236 lny. Directa 70HP Ø98.4	325 142
210000	J6 1961/71	DIESEL	4927cc.	300D 97HP Ø98.3	05
210200	C50 Turbo 1971/79	DIESEL	4927cc.	300DX Turbo 97HP Ø98.3	07
210300	J6 1956/61	DIESEL	4927cc.	300D 97HP Ø98.3	08
210100	350H - C60 - 714 1971/79	DIESEL	5755cc.	350D - CD600 137HP Ø106.36	06
410900	Brasil D60 - D70	DIESEL	5840cc.	6-357 Agrícola 91HP - Industrial 108HP Ø104.14	145
CIMARRON					
210500	3300D 1986/...	DIESEL	3283cc.	3300D 89HP Ø98.42	12
210400	3300D 1976/85	DIESEL	3285cc.	3300D 88HP Ø98.3	11
210600	3800D 1979/85	DIESEL	3840cc.	3800D 99HP Ø106.4	13
210700	3800D 1986/...	DIESEL	3840cc.	3800D 99HP Ø106.4	14
CUMMINS					
870000	Serie B - F100 1998/... - F4000 2000/... - Cargo 915 - Euro II	DIESEL	3900cc.	4B - 4BT - 4BTA 100/130HP Ø102	15
870500	Bus - Agrale - Euro III/IV - Electrónico 2003/...	DIESEL	3920cc.	ISBe 150/170HP Ø102	21
800800	ISB 2004/...	DIESEL	5883cc.	ISBe 6 275HP Ø102	61
870100	Serie B - F14000/F4000 - 1416 Euro I, Dodge Truck 359	DIESEL	5900cc.	6B - 6BT - 6BTA 180/205/330HP Ø102	17
870600	Serie C - Bus 17260EOT/18320EOT - Cargo 2003/...	DIESEL	8270cc.	ISCe 6 Serie 1832/2632 315HP Ø114	22
870200	Serie C - Bus - Camión - Cargo 1722/1730/2625 - F14000	DIESEL	8300cc.	6C - 6CT - CTA 254/294HP Ø114	19
870307	Serie C - Bus - Cargo 1722/1730/2625 1998/... - F14000	DIESEL	8300cc.	6C - 6CT - CTA 254/294HP Ø114	XXIII
DEUTZ					
650000	A40 - Tractor	DIESEL	2660cc.	F 2L 514 56HP Ø110	23
650200	69/75 A46 -Tractor 74/78 A65 1969/75	DIESEL	2908cc.	AF 2L 1114 Ø115	25
660000	913 1978/81	DIESEL	3064cc.	BF 3L 913 Ø102	35
650200	69/75 A46 - Tractor 74/78 A65 1969/75	DIESEL	3167cc.	AF 2L 2114 Ø120	25
650300	514 - Tractor A55 1959/69	DIESEL	3990cc.	F 3L 514 50HP Ø110	26
660100	913 - Agrale 4.913, Turbo 4.913 1978/...	DIESEL	4086cc.	F 4L 913 87HP Ø102	36
650600	1114 - Tractor A65 1969/78	DIESEL	4363cc.	AF 3L 1114 Ø115	29
650600	2114 - Tractor A65 1969/78	DIESEL	4750cc.	AF 3L 2114 Ø120	29
660200	913 1978/...	DIESEL	5106cc.	BF 5L 913 Ø102	37
650400	514 - Tractor 470 1959/69	DIESEL	5320cc.	F 4L 514 65HP Ø110	27
650700	1114 - Tractor A85 1969/78	DIESEL	5817cc.	AF 4L 1114 Ø115	30
650100	DD1000/DD9000 Camión - F7000 - Tractor 1978/81	DIESEL	6128cc.	F 6L 913 130HP Ø102	24
650700	2114 - Tractor A85 1969/78	DIESEL	6333cc.	AF 4L 2114 Ø120	30
650500	514 A110 - Tractor 1959/69	DIESEL	7980cc.	F 6L 514 Ø110	28
650800	1114 - Turbo - Bus - Tractor - A130/A144 1969/78	DIESEL	8725cc.	AF 6L 1114 Ø115	31
650800	2114 - Turbo - Bus - Tractor - A130/A144 1969/78	DIESEL	9500cc.	BF 6L 2114 Ø120	31
650900	200 D16/D19/D2M/RS, 210 EV 120, 5020 1969/77	DIESEL	11309cc.	F 8L 413 V8 Ø120	32
651000	Estacionarios 0302 6472 AY 0148/00 - 0301 7177 UY 0147/00 Omnibus, Camiones, 0302 6545 AY 0148/00 - 0301 7177 UY0147-00	DIESEL	11309cc.	F 8L 413 F V8 205HP Ø125	33



DODGE						
Ref.	Modelo/Model		Cm ³	Motor/Engine		
400000	D100/D200 1987/...	DIESEL	3336cc.	4.203-P4-192Z 71HP Ø91.49	322	121
400100	DP 400/500 1964/...	DIESEL	5004cc.	6.305 Cadenero 100HP Ø91.44		122
440100	Camión 1978/...	DIESEL	5100cc.	D225-6 102HP Ø95		120
400200	DP 600/800 1968/...	DIESEL	5798cc.	6.354-2 140HP Ø98.47		123
400400	D600/800 1976/...	DIESEL	5798cc.	6.354-4 Turbo 172HP Ø98.42		125
400900	DP 600/800	DIESEL	5798cc.	6.354-1 135HP Ø98.43		128
410900	P700D - P900	DIESEL	5840cc.	6-357 Agrícola 91HP - Industrial 108HP Ø104.14		145
870100	Truck 359 1989/93 - Ram 2007/...	DIESEL	5883cc.	6B 330HP Ø102		17

DYNAPAC						
330800	Cilindro Vibratorio CHF 44 1983/...	DIESEL	2942cc.	D229-3 72HP Ø102		116

FIAT TRACTOR / CAMION						
710200	Motor Arranque, Tractor 1955/74	DIESEL	665cc.	Motorino 55/60/788R Ø75		50
700600	Tractor U25 1957/62, Tractor 211R 1962/65	DIESEL	1135cc.	U25 - 211R - CD Ø85		45
700900	Tractor 411R/411T/431R 1959/85	DIESEL	2270cc.	615 40HP Ø85		48
710305	Tractor	DIESEL	2592cc.	480-540T 100HP		XXVI
440000	850E	DIESEL	2977cc.	D225-4 68HP Ø95		119
700300	Tractor Someca - CN3 1961/70	DIESEL	3421cc.	650 - 700 Ø110		42
700800	Tractor 400 E.V.U - 500 - Super 600E - 480 1969/80	DIESEL	3421cc.	CN3 Ø110		47
710405	Tractor Camiones	DIESEL	3455cc.	640-670-680 100HP		XXVI
700400	Tractor Someca - Leoncino 1950/...	DIESEL	3456cc.	DA - 50 - 40 Ø100		43
710505	Tractor - Camiones 780 - 780 DT - 765C - 766 - 855	DIESEL	3663cc.	780/780DT Ø103		XXVI
700800	Tractor 400 E.V.U - 500 - Super 600E - 480 1969/80	DIESEL	3705cc.	CN4 Ø110		47
310400	Excavadora FB80	DIESEL	3922cc.	D229-4 96HP Ø102	317	107
700000	Tractor Someca 1965/74	DIESEL	4156cc.	M45 - 450 - 55 Super Son Ø105		39
700300	Someca M45/M50 - Super Som 55/46A - Tigrotto 1969/...	DIESEL	4397cc.	CO3 Ø108		42
440100	Tractor AD7B - 980E - S90	DIESEL	5100cc.	D225-6 102HP Ø95		120
700500	Tractor - CO3 1971/80	DIESEL	5401cc.	700E - 800E - CO3 - 640 - 740 90/106HP Ø115		44
310500	Tractor S90 - FE105 - FA120 - FE105B	DIESEL	5883cc.	D229-6 145HP Turbo 160HP Ø102		109
700700	Tractor 1955/...	DIESEL	6546cc.	60 RL Ø122		46
700100	Tractor 1962/69	DIESEL	6872cc.	780 - R - AE Ø125		40
700200	Tractor - CP3 1972/80	DIESEL	7412cc.	840 - 900 - 1100 - CP3 - 900E 165HP Ø110		41
710100	Camión 1964/83	DIESEL	7412cc.	673N - CP - 840 - 900 Ø110		49
800100	Camión 203	DIESEL	10676cc.	682 N2 MK3 Ø125		53

FIAT IVECO						
800407	Iveco 150 Turbo Eurocargo	DIESEL	3666cc.	8040.04 Ø103		XXVI
800300	Camión 150 N Turbo AU130, Eurocargo 150 E23, 150 E20	DIESEL	5861cc.	8060.25 177HP - 8060.45/45S 207HP Ø104		55
800600	75/80/85/95/100/120/130/150/170 E15 Turbo 1991/... - 80/85/100/120 130/135/150/170 E18 Turbo 1991/... - 80/90/100/E21 - 135/150/170/180/E23	DIESEL	5861cc.	8060.25 143/177HP - 8060.45/S Eurocargo 207/277HP Ø104		59
800800	Eurocargo 80 E18 - 80 E21 - 90 E18 - 90 E21 Tector 2004/... Common Rail Turbo Intercooler EDC 130 E18 - 120 E24 - 120 E28 - 150 E18	DIESEL	5880cc.	170E22 - F4AE0681D 24V TDI- EDC 180/210HP Ø102 Tector Common Rail Turbo Intercooler		61
800900	Eurotech E24/E31/E35 - Eurotrakker/Euromover E24/E27/E31/E35/T27 T31/T33/T35/T36 - Stralis S27/S30/S31/S33/S35/S36 - Cavallino 2007/...	DIESEL	8000cc.	F2BE0681 - F2BE3681 E4 - 310HP Ø115 Cursor 8 - Turbo Intercooler		62
800200	Camión Bus 341A/221/221H, 619 NP, 693 N/N1/T/T1 1965/68	DIESEL	12883cc.	221 - 8210.01 240HP Ø135		54
801000	Euro Stard 260E48 - 440E46/48 - Stralis 260 - 440S44-190/260/440S48 260/440S50/54/56 - Eurotrakker 190/260/340/380E38/E44-400/410/440/720E38	DIESEL	13000cc.	F3BE3681A 380/420HP Ø135 Cursor 13 - Turbo Intercooler		64
800000	Camión 619N1/697N TB - Bus 391/691/319N - 221A 1970/...	DIESEL	13798cc.	8210.02 260HP Ø137		51
800500	Euro Trakker - Euro Star - Euro Tech 1989/... - 180E42 - 190E31/E42 190E36 - 240E42/E36 - 260E37/E42/E36 - 400E31/E37/E42 410E37/E42 - 440E37/E42 - 720E31 - 380E31 1991/...	DIESEL	13798cc.	8210.42L LE2 370HP - 8210.42K KE2 420HP 8210.22.800 310HP Ø137		57

FORD TRACTOR / CAMION						
330000	Tractor 4600/4110/4140/4190/4200/4410/4610/4610H/4610SU	DIESEL	3294cc.	BSD 332 - 333/H 81HP Ø111.8		65
870000	F4000 2000/... - Cargo 915 - Euro II	DIESEL	3900cc.	4B - 4BT - 4BTA 100/130HP Ø102		15
310400	F1000 1994/96 - F4000 1992/93, F2000 - FB4000 1980/...	DIESEL	3922cc.	D229-4 96HP Ø102	317	107
320400	Camión F4000 1986/...	DIESEL	4156cc.	D226-4 82HP Ø105		111

INDICE - CATALOGO PESADO

Index- Heavy Duty Catalog



FORD TRACTOR / CAMION					
Ref.	Modelo/Model		Cm³	Motor/Engine	
330100	Tractor 5610/5030/5110/5610/5900/6600/6700/7000/7100/7200	DIESEL	4196cc.	BSD 442 - 256 72HP Ø111.8	66
330400	Euro I/II/III	DIESEL	4300cc.	4.10X10 90HP - 4.10T/TCA 133/167HP Ø103	113
330100	Tractor 6410/6610/6710/7600/7700	DIESEL	4385cc.	BSD 444 80HP Ø111.8	66
330100	Tractor 6810/7410/7610/7710	DIESEL	4392cc.	BSD 444T 82HP Ø111.8	66
330100	F2000/4000 - FB4000 - Tractor 6600/6610	DIESEL	4393cc.	268 82/87HP Ø111.8	66
400100	F350/600	DIESEL	5004cc.	6.305 Cadenero 100HP Ø91.44	122
400300	F350/600 1974/...	DIESEL	5004cc.	6PF - 305 102HP Ø91.44	124
410100	F600	DIESEL	5004cc.	6PF - 305 Potenciado 100HP Ø91.49	137
400200	F600/700	DIESEL	5798cc.	6.354-2 140HP Ø98.47	123
400400	F7000 Camiones - Ford pesados y semi-pesados	DIESEL	5798cc.	6.354-4 Turbo 172HP Ø98.42	125
400900	F600/700	DIESEL	5798cc.	6.354-1 135HP Ø98.43	128
410900	F600/750/1100 - MF3366 - F6000/F7500/F11000	DIESEL	5840cc.	6-357 Agrícola 91HP - Industrial 108HP Ø104.14	145
420000	F400/600/7000/11000/12000/13000	DIESEL	5840cc.	6-358 Agrícola 118HP - Industrial 127HP Ø104.14	146
310500	F14000/F4000 1994/96 - Cargo - F12000/F14000 1985/...	DIESEL	5883cc.	D229-6 145HP Turbo 160HP Ø102	109
870100	F14000/F4000 1999/... -1416 Euro I 1989/93	DIESEL	5900cc.	6B - 6BT - 6BTA 180/205HP Ø102	17
650100	F7000 1978/81	DIESEL	6128cc.	F 6L 913 130HP Ø102	24
330700	F14000 1995/98, Euro I/II	DIESEL	6450cc.	6.10 X10 139HP - 6.10T/TCA 201/250HP Ø103	114
330200	7810/7910/8210/8530 1988/... - 8630/8750/8830 1992/...	DIESEL	6572cc.	Fase I-II Cargo 6.6/7.8 110HP Ø111.8	67
870600	2632-E/2932-E/4432-E/5032-E - Cargo 2003/...	DIESEL	8270cc.	iSCe 6 24V Serie C 1832/2632 315HP Ø114	22
870200	Bus/Camión/Agrícola- Cargo 1722/1730/2625 - F14000 1999/...	DIESEL	8300cc.	6C - 6CT - CTA 254/294HP Ø114	19
870307	Bus - Cargo 1722/1730/2625 1998/... - F14000	DIESEL	8300cc.	6C - 6CT - CTA 254/294HP Ø114	XXVIII

HANOMAG					
750100	Tractor D28LA - D28 1950/55	DIESEL	2800cc.	R25 - L28 - R35 - R40 R435 Brillant Ø90	70
750200	Brillant - Tractor D28C 1965/71	DIESEL	2800cc.	R40 25e - R57 - R46 Ø90	71
750000	Tractor D57 1963/...	DIESEL	5702cc.	R45 - R55 - R60 - R75 Ø110	69

IVECO Ver/See Fiat Iveco

JOHN DEERE					
850000	1030/1035/1520/1530/204/JD302 1973/...	DIESEL	2696cc.	3164D Ø102	73
850100	Tractor Equipos Viales 2120/2030/2035/2270/2280/2340	DIESEL	3590cc.	4219 D 81HP Ø102	74
	440/450/480, 2130/2135/1640/1840/2140/JD4400/540B/550/555		3918cc.	4239 D/T 81HP Ø102	
850700	Motores Agrícolas e Industriales	DIESEL	4500cc.	4540TJ31 107HP - 4045DJ31 74HP Ø106	80
850300	3420 - J10 - 4420 - 570 - Tractor Motoniveladora 1972/...	DIESEL	4976cc.	303 85HP Ø98.04	76
850300	3420 - J10 - 4420 - 570 - Tractor Motoniveladora 1972/...	DIESEL	5393cc.	329 87HP Ø102	76
850600	6505/6605/7500 - Power Tech MUM - Power Tech Gen Set	DIESEL	5395cc.	6068TJ31/J32/J61 - 6068HJ63 150/178HP Ø106	79
850200	Tractor Motoniveladora 6329D, 3120/3130/3135/2840/630/730	DIESEL	5395cc.	6.329D 87HP Ø102	75
	JD303/444/540/570/6359D - 3140/3040/3640/960/975/2940/3050		5877cc.	6.359D 87HP Ø106.5	
850400	3350/3550/6500/6600/7500 - Cosechadora 1075 1991/...	DIESEL	5879cc.	6.359D 110/125HP Ø106.5	77
850500	730 - Tractor 375 1960/74	DIESEL	6156cc.	Ø155.6	78

MAHINDRA					
930007	Tractor 255DI/265DI - Pick Up	DIESEL	1300cc.	25HP Ø89.9	XXX
930007	Tractor 255DI/265DI - Pick Up	DIESEL	1800cc.	30HP Ø89.9	XXX
930007	Tractor 255DI/265DI - Pick Up	DIESEL	2500cc.	55HP Ø89.9	XXX

MASSEY FERGUSON Ver/See Perkins

MAXION INTERNATIONAL					
410600	GM D10 - F350 - VW6.80 - Case 550	DIESEL	3860cc.	4.236 lny. Directa 70HP Ø98.4	325 142
401100	MF290/292/610/620	DIESEL	4110cc.	P4000-4000T 72/86HP Ø100	130

MERCEDES BENZ					
360100	240D/TD 1973/... - 207/307/407/507/510D - L406/407DG	DIESEL	2404cc.	OM 616.912/934/960 65HP Ø91	310 100
	0309D 1977/... - 240GD 1976/87 - MB100/200/300/400/180D/150/170			OM 616.916/940/961/963 72HP Ø91	
350100	MB L608 D/Unimog 1966/...	DIESEL	3786cc.	OM 314 85HP Ø97	84
350800	711D/811D/609D/614D/709D/809D - OM364 Aspirado 1987/...	DIESEL	3971cc.	OM 364 90/115HP Ø97.5	92
351000	Vario 614/814/815/810 - Atego 712/714/715/717/720/812/814/815/817 917/1017/1214/1215/1217/1317/1517	DIESEL	4250cc.	OM 904 LA/LA IMO Electrónico 75/125HP Ø102	95
350000	MB 3500 - L3250/L3500 1949/52	DIESEL	4580cc.	L911 OM311/312 98HP Ø90	83



MERCEDES BENZ					
Ref.	Modelo/Model		Cm³	Motor/Engine	
350200	MB 1112/1114/0140/L1112/L1514 1957/...	DIESEL	5100cc.	OM 321 108HP Ø95	85
350300	MB 1114/0140 1972/..., OM 352 Turbinado - Aspirado 1981/...	DIESEL	5675cc.	OM 352 100HP Ø97	86
350400	MB 1517 Turbo - 0170/L911/L1518 1978/...	DIESEL	5675cc.	OM 352A 130HP Ø97	88
360200	Turbinado Aspirado 1981/...	DIESEL	5675cc.	OM352 - OM352A Ø97	101
352200	MB 1518 1991/... - Motor Híbrido.	DIESEL	5765cc.	OM 352 - OM 352A Turbo 130HP Ø97	97
350900	OH1215/1315/1316/1319/1320/1420 - Aspirado Turbo 1620 OHL1621/OS1318, L1915/1314/1318/1365/2018/3611R/2214/2217	DIESEL	5957cc.	OM 366 138HP - OM 366A/LA 170HP Euro Ecológico Ø97.50	93
352000	Atego I 925/1225/1228/1325/1328/1525/1528/1823/1828/2523/2528	DIESEL	6370cc.	OM906 LA 18V Electrónico 231/245/279HP Ø102	96
350600	MB 1521/1526 1985/87	DIESEL	9650cc.	OM 355-5 84HP Ø128	90
360000	1630/1632/1633 - MB485.980 - MB489.960/961 - MB475.907 MB475.950/954/976/979/982/984/986/989/991/994/997/998	DIESEL	9973cc.	OM449A/LA - HLA 5 cilindros 180/200HP Ø128	99
360400	0371, Bus 1926 1985/...	DIESEL	11580cc.	OM 355-6 230HP Ø128	103
360300	O372/O400/L1395/1939/1941 1973/...	DIESEL	11967cc.	OM 447-6 250/300HP Ø128	102
360800	OM457.933/938/940/944/949 - OM458.960/970/980/938CAM O400BUS - Camión LS1938 - LK - LS/L2638 - Axor 2035/40/44	DIESEL	11967cc.	OM457LA/LAIII/HLA/HLA III Electrónico 252 - 456PS 24V 355/380HP Ø128	105

MWM					
320800	Tractor 65ID, 62ID 1970/76	DIESEL	2550cc.	D225-3 50HP Ø95	112
330800	Camión TX 1600 - Cilindro Vibratorio CHF 44 - Autoelevador	DIESEL	2942cc.	D229-3 72HP Ø102	116
440000	850E	DIESEL	2977cc.	D225-4 68HP Ø95	119
440000	Tractor 85ID 1970/76	DIESEL	3400cc.	D225-4 68HP Ø95	119
310400	F1000/F4000/F2000/FB4000 - Escavadora FB80 1980/...	DIESEL	3922cc.	D229-4 96HP Ø102	317 107
320400	Valmet Tractor 86 ID - Camión F4000 - Tractor 85 1986/...	DIESEL	4156cc.	D226-4 82HP Ø105	111
330400	7000/7500/8500- Euro I/II/III - VW7100/8120/8140/8150/13150	DIESEL	4300cc.	4.10 X10 90HP - 4.10T/TCA 133/167HP Ø103	113
440100	Camión 1978/... - Tractor AD7B - 980E - S90 - Valmet 110 ID	DIESEL	5100cc.	D225-6 102HP Ø95	120
310500	F4000/12000/14000 - Tractor S90 - FE105/FA120/FE105B	DIESEL	5883cc.	D229-6 145HP Turbo 160HP Ø102	109
330700	F14000 1995/98 - Euro I/II - VW 13180/15180/16210	DIESEL	6450cc.	6.10 X10 139HP - 6.10T/TCA 201/250HP Ø103	114
331200	Agrale 8500/9200 - Constelation 13.180E- 15.180E	DIESEL	4800cc.	4.12TCE Common Rail 150/180HP Ø105	117
331300	VM210/260/310 - 26.260E/31.260E - 17.260EOT/17.210EOD	DIESEL	7118cc.	6.12 TCE Common Rail 210/260/310HP Ø105	118

PERKINS / MASSEY FERGUSON					
420600	Rover - Maestro D/TD - Perkins - Marino 4.20 D/TD Leyland Sherpa 185/200/215/220/230/240/255 - Daf Ka 200/VS 200	DIESEL	1994cc.	Prima 65/80T - Leyland Prima 65 Daf TN 44 64/80HP Ø84.45	327 150
420400	MF50/50X/55X/135/200/235/250, MF 135/515	DIESEL	2360cc.	3.152 42HP Ø89	149
400500	Tractor Viñatero	DIESEL	2362cc.	P3 - 152 42HP Ø91.44	126
422000	MF133/135/230/235/240/254/353, Industrial MF40, Agrícola	DIESEL	2500cc.	D3.152-D3.152/2-G3.152-D3.152/4 100HP Ø91.40	151
410200	Tractor - MF50 Tractor - MF50X/55X - MF135/200/235/250	DIESEL	2502cc.	P3 - 152 42HP Ø91.44	138
420400	MF50/50X/55X/135/200/235/250 - MF 135/515	DIESEL	2502cc.	3.152 42HP Ø91.44	149
423000	Case-IH CS 68/75 - Challenger	DIESEL	3300cc.	320D/DS Agco Sisu Power 33/69HP Ø108	01
410500	MF65X - MF40B/65/155/158/165/260/155/164C - CBC1000	DIESEL	3330cc.	D4.203/AD4.203 Iny. Directa 71HP Ø91.4	141
410800	Pick Up - Camiones livianos	DIESEL	3330cc.	T 4.33 Turbo Iny. Directa 91/95HP Ø91.46	326 144
400000	D100 - D200 1987/... - F100 - Falcon 1970/...	DIESEL	3336cc.	4.203-P4-192Z 71HP Ø91.49	322 121
400700	Tractor M165/265	DIESEL	3336cc.	MF165 - 265 71HP Ø91.49	81
410000	F100	DIESEL	3336cc.	4.203 Potenciado 71HP Ø91.44	324 136
410300	Potenciado	DIESEL	3336cc.	MF265 Potenciado 71HP Ø91.44	139
420100	Tractor 8 BR	DIESEL	3336cc.	4.203 - 8 BR Iny. Indirecta 71HP Ø91.49	147
401000	Vehicular GM D20	DIESEL	3860cc.	Q20B4 Iny. Directa 70HP Ø98.4	323 129
410600	MF220 - F290 - Tractor MF85X - GM D10/D20/D40 - F350	DIESEL	3860cc.	Q20B4 - 4.236 Iny. Directa 70HP Ø98.4	325 142
420200	Case 580H	DIESEL	3860cc.	4.236 Iny. Directa 70HP Ø98.4	148
401500	Phaser 90/110T/120 Ti - 4.40/T4.40/C4.40-MF6130/6140/6150	DIESEL	3990cc.	1004.4/T/TW Ø100	131
410600	MF220/290 - Tractor MF85X	DIESEL	4070cc.	4.248 70HP Ø101	325 142
410700	Case 580H - MF85/270/285/290/220/220A - Hyster H110	DIESEL	4070cc.	A4 - 248 75HP Ø100	143
420200	Case 580H	DIESEL	4070cc.	4.248 Iny. Directa 100HP Ø100	148
401100	MF290/292/610/620	DIESEL	4100cc.	P4000-4000T 72/86HP Ø100	130
320400	Tractor 85 1986/...	DIESEL	4156cc.	D226-4 82HP Ø105	111
423100	MF4292/MF4297 - Challenger	DIESEL	4400cc.	420D/DS Agco Sisu Power 106/129HP Ø108	02

INDICE - CATALOGO PESADO

Index- Heavy Duty Catalog



PERKINS / MASSEY FERGUSON					
Ref.	Modelo/Model		Cm³	Motor/Engine	
400100	DP 400/500 1964/... - F350/600	DIESEL	5004cc.	6.305 Cadenero 100HP Ø91.44	122
400300	F350/600 1974/...	DIESEL	5004cc.	6PF - 305 102HP Ø91.44	124
400600	Tractor - PF	DIESEL	5004cc.	6PF - MF1175 100HP Ø91.44	127
410100	F600	DIESEL	5004cc.	6PF - 305 Potenciado 100HP Ø91.49	137
400200	DP 600/800 1968/..., F600/700	DIESEL	5798cc.	6.354-2 140HP Ø98.47	123
400400	D600/800 1976/... - F7000 Camiones - Pesados y semi	DIESEL	5798cc.	6.354-4 Turbo 172HP Ø98.42	125
400800	Tractor 1095/1098/1195/1215	DIESEL	5798cc.	6.354-2 140HP Ø98.3	82
400900	DP 600/800 - F600/700	DIESEL	5798cc.	6.354-1 135HP Ø98.43	128
401700	1095/1098/1215 - Tractores - Estancieros - Grúas - Rodantes	DIESEL	5798cc.	6.354-2 Turbo Ø98.47	134
410400	Tractor 1215/1218	DIESEL	5798cc.	T6.354-4 172HP Ø98.63	140
410900	Brasil D60/D70 - F600/750/1100/6000/F7500/11000 - MF3366	DIESEL	5840cc.	6-357 Agrícola 91HP - Industrial 108HP Ø104.14	145
420000	F400/600/7000/11000/12000/13000 - MF 400C	DIESEL	5840cc.	6-358 Agrícola 91HP - Industrial 108HP Ø104.14	146
401600	Phaser 125 - MF396/399/630/640/3085/6160/6170 - Phaser 160/180Ti MF660/3114/3125/3625/3635/3655/6189/6190/8110 - 8120/8130 - MF399 1994/...	DIESEL	5985cc.	1006.6/C/T/TW Ø100	132
423200	Case-IH CS/CVX120/130/150 - CVX1135/1145/1155/1170/1190	DIESEL	6600cc.	620S/DS Agco Sisu Power 147/189HP Ø89	03
420508	D170, P 200/260/270/320, MF RX 100T	DIESEL	8850cc.	510 -540 V8 Ø108 170/183HP	
SCANIA					
810000	Camión - Omnibus L75/76 - L/LB/LBS110/L111/LB111/LS111/LT111	DIESEL	11020cc.	D11 - DS11 280/333HP Ø127	153
810100	LB1107LBS110 - L111/LS111/LT111/LBS111/LBT111 - G112 - L112/R112 T112- P113/P113HK/R113/R113HK/T113/K113CBL/K113GLP/K113TLP/K113TLP	DIESEL	11020cc.	D11 - DS11 - DSC11 272/354HP Ø127	154
810407/8	P124 - R124 - T124 1996/2001	DIESEL	11700cc.	DSC12.01/02 360/420HP Ø127	XXXIV
810208	R142/T142/R143/T143/R144/T144	DIESEL	14190cc.	D14 - DS14 - DSC14 400/460/500/530HP Ø127	XXXIV
SHANGAI					
910900	Tractor	DIESEL		495A Tracción Simple - 485A18 Tracción Doble	157
VALMET					
320800	Tractor 65 ID - 62 ID 1970/76	DIESEL	2550cc.	D225-3 50HP Ø95	112
330800	Autoelevador - E300 - Tractor 68 1983/...	DIESEL	2942cc.	D229-3 72HP Ø102	116
440000	Tractor 85 ID 1970/76	DIESEL	3400cc.	D225-4 68HP Ø95	119
320400	Tractor 86 ID	DIESEL	4156cc.	D226-4 82HP Ø105	111
440100	Tractor 110 ID	DIESEL	5100cc.	D225-6 102HP Ø95	120
VALTRA					
423000	A65/A75, 305/355/365/405/455/465/555/565/600/700	DIESEL	3300cc.	320D/DS Agco Sisu Power 33/69HP Ø108	01
423100	A950/A990/BM100/BM110 (4x2, 4x4)	DIESEL	4400cc.	420D/DS Agco Sisu Power 106/129HP Ø108	02
423200	8000	DIESEL	6600cc.	620D/DS Agco Sisu Power 147/189 Ø108	03
VOLVO					
880908	B7- FL7 1985/... - FL7 - FS7 1991/... - B7R 1998/...	DIESEL	6725cc.	TD71F/FA/FAQ/FC/FCQ/FD/FQ/FS/FSQ/G/E 230/245HP TD73E/ES 230/260HP D7A/B 260/285HP Ø104.8	XXXV
331300	VM210/260/310	DIESEL	7118cc.	6.12 TCE Common Rail 210/260/310HP Ø105	118
880000	B58 - B10M 1987/...	DIESEL	9600cc.	THD 101 KC 273/310HP Ø120.6	159
880100	B58 1980/85	DIESEL	9600cc.	THD 100D 230/260HP Ø120.6	161
880200	N10 1980/85	DIESEL	9600cc.	TD 100A 230/260HP Ø120.6	163
880300	N10 1985/89	DIESEL	9600cc.	TD 100G - 101G - 101F 273/300HP Ø120.6	165
880500	NL10 1998/	DIESEL	9600cc.	EDC Ø120.6	169
880600	NL10 1989/97	DIESEL	9600cc.	TD 102F - 102FS 234/317HP Ø120.6	171
880400	N12 1980/89	DIESEL	11950cc.	TD 121G/120GA - 121F 295/360/385HP Ø130.2	167
880700	NL12 1997/...	DIESEL	11950cc.	EDC Ø120.6	173
880800	NL12 1989/96	DIESEL	11950cc.	TD 122FS 396HP Ø130.2	175
VOLKSWAGEN					
330400	7100/8120/8140/8150/13150	DIESEL	4300cc.	4.10 X10 90HP - 4.10T/TCA 133/167HP Ø103	113
330700	13180/15180/16210	DIESEL	6450cc.	6.10 X10 139HP - 6.10T/TCA 201/250HP Ø103	114
331200	Constellation 13.180E - 15.180E	DIESEL	4800cc.	4.12TCE Common Rail 150/180HP Ø105	117
331300	26.260E - 31.260E - 17.260EOT - 17.210EOD	DIESEL	7118cc.	6.12 TCE Common Rail 210/260/310HP Ø105	118
870600	17220/17300/17310/18310/19320/26320/17250E/19320E/24250E Bus 17260EOT/18320EOT 2003/...	DIESEL	8270cc.	ISCe 6 24V Serie 1832/2632 315HP Ø114	22



ANTIGUA EXPRESIÓN DE CÓDIGO TARANTO

NUEVA EXPRESIÓN DE CÓDIGO TARANTO

FORMADO POR CINCO DÍGITOS



REFERENCIA ANTERIOR

FORMADA POR SEIS DÍGITOS



REFERENCIA NUEVA



DOS PRIMEROS DÍGITOS

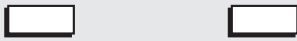

INDICA EL RUBRO O LINEA AL CUAL PERTENECE EL ARTÍCULO

ARTÍCULOS DE FABRICACIÓN

- 14 → AUTO UNIÓN
- 15 → CITROËN
- 20 → CHEVROLET - OPEL
- 21 → CHEVROLET - BEDFORD
CIMARRON - DI TELLA
- 22 → DODGE - CHRYSLER - VW
- 23 → VW - FORD
- 24 → CHEVROLET - GM
- 25 → FIAT
- 26 → FIAT
- 27 → FIAT
- 28 → CHEVROLET - GM
- 30 → FORD - VW
- 31 → FORD - MWM
- 32 → FORD - MWM
- 33 → FORD - MWM
- 35 → MERCEDES BENZ
- 36 → MERCEDES BENZ
- 40 → PERKINS / MF. / PF
- 41 → PERKINS / MF.
- 42 → PERKINS / MF.
- 43 → MAXION
- 45 → PEUGEOT - INDENOR
- 46 → PEUGEOT
- 47 → PEUGEOT
- 50 → RASTROJERO - INDENOR
VM - BORGWARD
- 51 → CHRYSLER
- 52 → CHRYSLER
- 54 → IKA - RENAULT - WILLYS
- 55 → RENAULT
- 56 → RENAULT - DACIA
- 57 → RENAULT
- 58 → RENAULT
- 65 → DEUTZ

- 66 → DEUTZ
- 70 → FIAT TRACTORES
- 71 → FIAT TRATOR - CAMINHÃO
- 75 → HANOMAG
- 80 → FIAT CAMINHÕES / IVECO
- 81 → SCANIA VABIS
- 85 → JOHN DEERE
- 86 → HONDA - ROVER
- 87 → CUMMINS
- 90 → ASIA MOTORS - KIA
NISSAN
- 91 → KIA - MITSUBISHI
SUZUKI - TOYOTA
- 92 → TATA
- 93 → ISUZU
- 94 → DAEWOO
- 95 → DAIHATSU - BMW
MITSUBISHI - TOYOTA
SUBARU
- 96 → MITSUBISHI
- 97 → TOYOTA - MAZDA - LADA
- 98 → BMW
- 99 → HYUNDAI

TERCER Y CUARTO DÍGITO

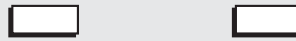

ESPECIFICA E INDICA EL TIPO DE MODELO AL QUE PERTENECE

ARTÍCULOS DE FABRICACIÓN

EJEMPLOS

CITROËN

- 00 → 2CV 14HP
- 01 → 2CV 18HP
- 02 → 3CV
- 04 → AMI 8

FIAT

- 00 → 1100
- 01 → 600
- 02 → 1500
- 03 → 1600
- 04 → 128 1100cc.
- 05 → 128 1300cc.
- 06 → 128 1500cc.
- 07 → 125
- 08 → 133
- 09 → REGATTA 100S
- 11 → DUCATO 2.8
- 20 → BRAVO/A TD
- 21 → BRAVO/A JTD

FORD

- 00 → FALCON 7B
- 01 → FALCON SP
- 02 → V8 FASE 1
- 03 → TAUNUS 2.0
- 04 → TAUNUS 2.3
- 05 → V8 FASE 2
- 06 → SIERRA 1.6
- 08 → A/AA
- 09 → FALCON 4B
- 14 → ESCORT 1.6
- 20 → TRANSIT 2.5
- 21 → FIESTA 1.4

PERKINS

- 00 → 4-203
- 01 → 6-305
- 02 → 6-354 F2
- 03 → 6PF-305
- 04 → 6-354 F4
- 05 → P3-152
- 06 → PF-MF
- 07 → MF M165-265
- 08 → MF 1095-1098
- 09 → 6-354 F1
- 10 → GM D20 3.9

PEUGEOT

- 00 → 404
- 01 → 504 1.6
- 02 → 504 1.8
- 03 → 504 2.0
- 04 → 504 XD2
- 05 → 505
- 06 → 505 I
- 07 → 505 XD3
- 09 → 403
- 15 → 205 1.0
- 16 → 106 1.4
- 17 → 106 1.2
- 18 → 104 1.2

RASTROJERO

- 00 → 42 HP
- 01 → 52 HP
- 02 → INDENOR 4,88
- 03 → INDENOR 6 CIL
- 04 → VM/BORGWARD

QUINTO Y SEXTO DÍGITO

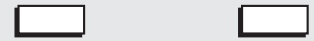

DETERMINA EL TIPO DE JUNTA

ARTÍCULOS DE FABRICACIÓN

- 00 → Jgo. Junta Motor
- 01 → Jgo. Motor sin Tapa Cilindros
- 05 → Jta. Tapa Cilindro Metalamianto
- 06 → Jta. Tapa Cilindro Supermedida
- 07 → Jta. Tapa Cilindro Libre de Amianto
- 08 → Jta. Tapa Cilindro Metálica
- 10 → Jta. Tapa de Válvulas
- 11 → Jta. Cártter
- 12 → Jta. Distribución
- 13 → Jta. Contratapa Distribución
- 14 → Jta. Bomba de Agua
- 15 → Jta. Múltiple Escape Ferroflex y Chapa
- 16 → Jta. Múltiple Escape Ferroflex
- 17 → Jta. Múltiple Admisión
- 18 → Jta. Salida de Escape
- 19 → Jta. Placa de Agua
- 20 → Jgo. Junta Carburador
- 21 → Jgo. Junta Carburador
- 22 → Jgo. Junta Carburador
- 23 → Jgo. Junta Carburador
- 24 → Jgo. Junta Carburador
- 25 → Jta. Base Carburador
- 26 → Jta. Tapa Carburador
- 27 → Jta. Bomba Aceite a Block
- 28 → Jta. Bomba de Nafta
- 29 → Arandela Tapón Cártter
- 30 → Arandela Tapa de Válvulas
- 36 → Jta. Tapa Válvulas Lateral
- 50 → Jgo. Caja de Velocidades
- 57 → Junta Palier
- 58 → Jgo. Bancada Cigüeñal
- 59 → Jta. Diferencial
- 60 → Jta. Cártter CGT
- 70 → Jgo. Suplemento Camisas
- 85 → Suplemento de Tapa
- 95 → Jgo. de Juntas Superior

FORMACIÓN DE CÓDIGOS DE RETENES

	SEGUNDO Y TERCER DÍGITO	CUARTO Y QUINTO DÍGITO	SEXTO Y SÉPTIMO DÍGITO	OCTAVO DÍGITO							
	<table border="1"><tr><td> </td><td> </td></tr></table>			<table border="1"><tr><td> </td><td> </td></tr></table>			<table border="1"><tr><td> </td><td> </td></tr></table>			<table border="1"><tr><td> </td></tr></table>	
	INDICA LA MARCA O LA LINEA DEL ARTÍCULO	INDICA EL TIPO DE MOTOR	INDICA TIPO DE RETÉN SEGÚN SU APLICACIÓN	INDICA MATERIAL							
PRIMER DÍGITO		EJEMPLOS									
R	14 → AUTO UNION 15 → CITROEN 20 → CHEVROLET 21 → CHEVROLET 22 → DODGE - VW 23 → VW - FORD 24 → CHEVROLET 25 → FIAT 26 → FIAT 27 → FIAT 28 → CHEVROLET 30 → FORD - VW 31 → FORD - MWM 32 → FORD	CITROËN 00 → 2CV 14HP 01 → 2CV 18HP 02 → 3CV 04 → AMI 8 FIAT 00 → 1100 01 → 600 02 → 1500 03 → 1600 04 → 128 1100cc. 05 → 128 1300cc.	00 → KIT DE RETENES 10 → GUÍAS DE VÁLVULAS 11 → BANCADA 12 → DISTRIBUCIÓN 13 → ÁRBOL DE LEVAS 15 → RET. ADICIONAL 47 → VELOCÍMETRO 48 → SELECTOR CAJA DE VELOCIDAD 49 → EJE CAMBIO 50 → SALIDA DA CAJA 51 → DE DIRECTA 52 → SALIDA DE PALIER 55 → RUEDA TRAS. EXT.	56 → RUEDA TRAS. INT. 57 → DE PIÑÓN 58 → RUEDA DEL. EXT. 59 → RUEDA DEL. INT. 60 → SEMI-EJE							
INDICA LINEA DE RETENES				N - NITRILÓ CAUCHO NITRILICO S - SILICÓN CAUCHO DE SILICONA P - POLIACRÍLICO CAUCHO DE POLIACRÍLICO V - VITÓN CAUCHO FLUORADO VF - VIFLON T - TEFLÓN POLITETRA FLUOR ETILENO							
PRIMER DÍGITO											
PR	35 → MERC. BENZ 36 → MERC. BENZ 40 → PERKINS - MF 41 → PERKINS - MF 42 → PERKINS 45 → PEUGEOT 46 → PEUGEOT 50 → RASTROJERO INDENOR 54 → IKA - RENAULT JEEP WILLYS 55 → RENAULT 58 → RENAULT										
INDICA LINEA DE PORTA RETENES											



SÍMBOLOS - SYMBOLS

Jgo. de juntas para motor con retenes Full set gaskets with oil seals		Jgo. de tornillos para tapa de cilindros Cylinder head bolts		Junta salida escape Exhaust pipe seals gaskets	
Jgo. de juntas para motor sin retenes Head set gaskets without seals		Herramientas especiales para motor Set of special automotive tools		Suplemento camisa cilindro Camma cylinder gaskets	
Jgo. de juntas p/motor sin tapa con retenes Full set gaskets without head with oil seals		Sellador Líquido - Caucho de Silicona Liquid Sealant - Silicone Rubber		Kit retenes completo Oil Seals (Set)	
Jgo. de juntas p/motor sin tapa sin retenes Full set gaskets without head without oil seals		Junta tapa de válvulas Valve gaskets		Jgo. retén válvulas Valve seal set	
Jgo. de juntas superior con retenes Head set gaskets with oil seals		Junta para cárter Rear main bearing seals gaskets		Retén bancada Rear crankshft seal	
Jgo. de juntas superior sin retenes Head set gaskets without seals		Junta tapa distribución Timing cover gaskets		Retén distribución Front crankshft seal	
Junta tapa cilindro Cylinder head gaskets		Junta bomba de agua Water pump and water exit gaskets		Retén árbol de levas Camshaft seal	
Junta tapa cilindro - No retorqueable Cylinder head gaskets - Non retorqueable		Junta múltiple admisión y escape Intake and exhaust manifolds gaskets		Porta retén bancada Rear crankshft seal	
Junta tapa cilindro izquierda Left Cylinder head gaskets		Junta múltiple admisión Intake manifolds gaskets		Porta retén distribución Front crankshft seal	
Junta tapa cilindro derecha Right Cylinder head gaskets		Junta múltiple escape Exhaust manifolds gaskets		Espesor Thickness	

ABREVIATURAS MATERIALES - ABBREVIATION OF MATERIALS

AC Acero Inoxidable Stainless Steel	CEL Celulosa Cellulose	NH Libre Amianto Comprimido Compressed Asbestos Free
ACO Acero Cobreado - Libre Amianto - Acero Cobreado Steel Copper - Asbestos Free - Steel Copper	F Fibra Fiber	MLS Multilamina Sterling Multisheet Sterling
AL Aluminio Aluminium	FCH Ferroflex con respaldo de chapa Ferroflex with tin shoulder	P Poliacrílico - Retenes con casco de acero Polyacrylic - Oil Seals with steel cap
BAK Bakelita - Nonasbesto/Bakelita Bakelite - Nonasbesto/Bakelite	FIE Fieltro Felt	PB Plomo Lead
CB Base Celulosa Cellulose Base	GFT Grafito con alma metálica Graphite with metallic core	PLAST Plástico Plastic
CG Corcho y Goma Cork and Rubber	GS Goma sintética - Nitrilo Synthetic Rubber - Nitrile	S Silicona - Retenes con casco de acero Silicone - Oil Seals with steel cap
CGT Corcho y Goma con Tela Cork and Rubber with Cloth	H Hojalata Tin Plate	SLS Sterling - Polystrat Sterling - Polystrat
CHA Chapa/Hojalata sin material blando Tin Plate without soft material	L Latón - Bronce Brass	SNA Soga libre de amianto Rope asbestos free
CN Arandelas blindadas (Cobre - Libre Amianto) Armored washers (Copper - Asbestos Free)	N Retenes de nítrico con casco de acero Nitrile oil seals with steel cap	T Teflón Teflon
CNC Cobre - Libre Amianto - Cobre Copper - Asbestos Free - Copper	NB Libre Amianto (Beater) Asbestos Free (Beater)	V Vitón - Retenes con casco de acero Viton - Oil Seals with steel cap
CU Cobre Copper	NFT Ferroflex Base Libre Amianto Ferroflex Base Asbestos Free	VS Varios Miscellaneous

Los números originales también indicados en este catálogo tienen relación únicamente en sentido de informar y verificar. Sírvase usar en sus pedidos, facturas recibos solamente los códigos TARANTO.

Os números originais indicados neste catálogo servem somente para informação e verificação. Utilizar nos pedidos, faturas e recibos somente os códigos TARANTO.

Original part numbers also indicated in this catalog are intended only to inform and verify. Please, indicate only TARANTO reference numbers in your order forms, invoices and shipping notes.

Die in diesem katalog aufgeführten nummern dienen ausschlie bich informations-und Vergleichszwecken. Bitte verwenden sie thren rechnungen, lieferscheinen und bestellungen nur TARANTO-nummern.

Les références de pièces d'origine indiquées sur ce Catalogue ont exclusivement te sens d'information et de vérification. Veuillez indiquer sur vos factures, bons de livraison et de commandes le numéro TARANTO.

ARANDELAS - ANILLOS - O'RINGS

Washers - Rings - O'rings

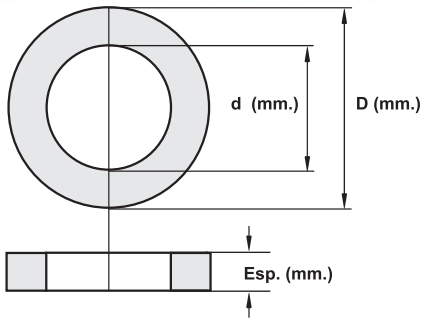

- > Diámetro interior d (mm)
- > Diámetro exterior D (mm)
- > Espesor Esp.(mm)
- > Diâmetro interno d (mm)
- > Diâmetro externo D (mm)
- > Espessura Esp.(mm)
- > Inner diameter d (mm)
- > Outer diameter D (mm)
- > Thickness Esp.(mm)

FORMACIÓN DE CÓDIGOS DE ARANDELAS

A 6 x 10.5 x 2 →

A
INDICA
ARANDELAS

6
INDICA d (mm)
Ø Interior

x
10.5
INDICA D (mm)
Ø Exterior

x
2
INDICA ESPESOR
(mm)

C
INDICA TIPO
DE MATERIAL

MATERIALES

AL	ALUMINIO	ALUMÍNIO	ALUMINUM	H	FERRO	HIERRO	IRON
NH	LIBRE AMIANTO COMPRIMIDO	SEM AMIANTO COMPRIMIDO	ASBESTOS FREE COMPRESSED	F	FELTRO	FIELTRO	FELT
C	COBRE	COBRE	COPPER	N	NYLON	NYLON	NYLON
F	FIBRA	FIBRA	FIBER				

ARANDELAS POR DIÁMETRO INTERIOR

				MATERIAL										MATERIAL										MATERIAL																
d (mm)	D (mm)	Esp		AL	NH	C	F	H	L	d (mm)	D (mm)	Esp		AL	NH	C	F	H	L	d (mm)	D (mm)	Esp		AL	NH	C	F	N	L	d (mm)	D (mm)	Esp		AL	NH	C	F	H	L	
4	7	1					●			7	17	1.5						●			10	13	1		●		●				12	17	1.5				●			
4	8	1	●							7	17	1						●			10	14	1.25	●							12	17	2				●			
5	8	1	●		●	●				8.3	11.6	1					●			10	14	1.5	●							12	18	1.5	●			●				
6.5	12	0.5					●			8.5	11.5	1						●		10	14	1				●	●			12	18	1				●				
6.8	13.5	1	●							8.5	12	1					●			10	15	1.5	●							12	18	2				●				
6	10.5	2					●			8	10	1	●							10	15	1				●				12	18	3	●			●				
6	10	1.5			●					8	11	1	●					●		10	16	0.5						●		13	16	0.5	●							
6	10	1	●		●	●				8	12	1	●			●	●			10	16	1	●		●	●				13	16	2				●				
6	10	2							●	8	12	1							●	10	16	2.5				●				13	17	1				●				
6	11	2					●			8	13	1	●			●				10	18	1				●				13	17	2	●							
6	8	0.5							●	8	13	2.5					●			10	18	2	●							13	18	1.5				●				
6	8	1	●				●			8	14	0.5					●			10	19	2				●				13	19	1					●			
6	9	0.5	●				●			8	14	1.5		●	●					10	20	1.5	●							13	20	1	●			●				
6	9	1	●				●	●		8	14	1	●			●				10	20	1				●				13	20	2	●							
6.5	10	1					●			8	18	1.5	●					●		10	20	2				●				13	21	1.5					●			
6.5	12	1					●			8	20	1.5	●							10	21	2				●				13	24	3						●		
7.5	15	2					●			9.4	18	1						●		11	15	1						●		14.5	21	2				●				
7	8.9	1.9							●	9.5	12	1.5	●							11	16	1	●				●			14	17.2	2				●				
7	10	1	●				●	●		9.5	12	1	●							11	17	1.25					●			14	18	1.25	●							
7	11	1					●	●		9.5	14.5	1						●		11	18	1.5	●			●				14	18	1.5				●				
7	12.5	1					●			9.5	20	1					●			11	18	2				●				14	18	1	●			●				
7	12.5	2					●			9.5	20	2					●			12.7	16	1	●							14	18	1.25				●				
7	13	1.5	●							9.7	13	1						●		12.8	22.8	2						●		14	19	1.5				●				
7	13	1					●			9	11	0.8	●							12	14	0.5	●							14	20	1.25	●							
7	13	4							●	9	13	0.5					●			12	15	1.5				●				14	20	1.5	●			●	●			
7	14	1							●	9	13	1	●							12	15.2	1				●				14	20	1				●				
7	15	1							●	9	13	1					●	●		12	16	1.5	●			●				14	20	2				●				
7	15	1.5					●			9	14	1					●			12	16	1	●			●	●			14	21	1.5				●				
7	15	2					●			9	17	1.5					●			12	17	1	●			●				14	22	1.5				●				

ARANDELAS - ANILLOS - O'RINGS

Washers - Rings - O'rings



MATERIAL							MATERIAL							MATERIAL							MATERIAL														
d (mm)	D (mm)	Esp	AL	NH	C	F	H	L	d (mm)	D (mm)	Esp	AL	NH	C	F	H	L	d (mm)	D (mm)	Esp	AL	NH	C	F	H	L	d (mm)	D (mm)	Esp	AL	NH	C	F	H	L
14	22	2			●				16	24	1			●				20	26	0.5			●				24	38	1.25	●					
14	24	1.5	●						16	24	1.5	●						20	26	1.5			●				25	29.5	1			●			
14	24	2			●				17	21	0.5			●				20	26	1	●		●				25	29	2			●			
14.7	21	2			●				17	21	1.25			●				20	26	2				●			26	31	2			●			
15.5	17	1.5			●				17	21	1.5			●				20	28	1	●		●				26	32	1.25	●					
15	18	1	●						17	22	1.25	●						21	30	2	●						26	32	2	●					
15	19	1.5	●						17	22	1.5			●				22.5	29	2	●		●				26	34	2	●					
15	20	1			●				17	22	1	●		●				22	26	1.5			●				27	32	1.5			●			
15	21	1.5	●						18	22	1.5	●		●				22	27	1	●						28	34	1.5	●					
15	21	1.5			●				18	22	2			●				22	27	1.25	●						28	36	0.5	●					
15	21	2	●		●				18	23	1.25	●		●				22	27	1.5			●				28	38	1.5			●			
16	19	1.5			●				18	23	1	●		●				22	27	1			●				30	36	2	●		●			
16	20	1	●			●			18	23	2			●				22	28	1.25	●						31	36	1.5	●					
16	20	1.5			●				18	24	1			●				22	28	1.5			●				32	36	0.5			●			
16	21	1.25	●						18	24	1.5			●				22	29	1.5	●						32	36	1			●			
16	21	1.5			●				19	24	1.5	●						22	29	3	●						35	41	2			●			
16	21	1	●						19	26	1.5			●				22	32	1.5			●				36	42	1.5	●					
16	21	2			●				19	27	2	●						24	29	2			●				40	47	1			●			
16	22	1.5	●		●				19.5	27	1	●						24	30	1.5	●						40	60	1.5			●			
16	22	1			●	●			20.5	5.5	1	●						24	32	1.5	●						45	52	2	●					
16	22	2			●				20	24	1.5	●		●				24	32	2	●														

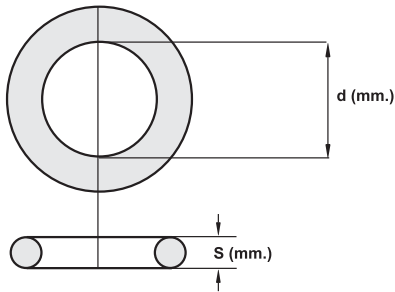

> Diámetro interior d (mm) > Diâmetro interno d (mm) > Inner diameter d (mm)
 > Sección S (mm) > Seção S (mm) > Section S (mm)

FORMACIÓN DE CÓDIGOS DE O'RING

G 18.77 x 1.78 S



G
INDICA LINEA DE O'RING

18.77
INDICA d (mm) Ø Interior

x

1.78
INDICA S (mm) Sección

S
INDICA TIPO DE MATERIAL

MATERIALES

N NITRILICO NITRILICA NITRILE S SILICONA SILICONE SILICONE V VITÓN FLUOR ELASTOMERO FLUORELASTOMERS

O'RING - SERIE STANDARD

1.78
S (mm)

d (mm)	MATERIAL			d (mm)	MATERIAL			d (mm)	MATERIAL			d (mm)	MATERIAL			d (mm)	MATERIAL		
d (mm)	N	S	V	d (mm)	N	S	V	d (mm)	N	S	V	d (mm)	N	S	V	d (mm)	N	S	V
1.42	●			4.47	●			12.42	●			23.52	●			50.52	●		
1.78	●			5.28	●			15.6	●		●	28.3	●			53.7	●		
2.57	●			6.07	●			17.17	●			34.65	●			56.87	●		●
2.9	●			7.65	●			18.77	●		●	44.17	●			60.05	●		
3.68	●			9.25	●			21.95	●			47.35	●			63.22	●		

2.62
S (mm)

7.59	●			13.11	●			17.12	●			23.47	●			30	●		
9.19	●			13.94	●			18.72	●			26.64	●			31.42	●		
9.5	●			15.54	●			20.30	●			28.24	●			32.99	●		
12.37	●			17.12	●		●	21.89	●			29.82	●			36.17	●		●



ARANDELAS - ANILLOS - O'RINGS

Washers - Rings - O'rings

O'RING - SERIE STANDARD

S (mm)	MATERIAL				MATERIAL				MATERIAL				MATERIAL				MATERIAL							
	d (mm)	N	S	V	d (mm)	N	S	V	d (mm)	N	S	V	d (mm)	N	S	V	d (mm)	N	S	V				
2.62	44.12	●			53.64	●			58.42	●			66.34	●			72.69	●			90	●		
	48.9	●			55.25	●			61.60	●			67.95	●			82.22	●			126.67	●		
	52.07	●			56.82	●			64.77	●			69.52	●			88.57	●			158.42	●		
3.53	4.34	●			21.82	●			31.34	●			40.87	●			50.39	●			98.02	●		
	12.29	●			23.39	●			32.92	●			44.04	●			63.09	●			107.54	●		
	13.87	●			26.57	●			36.09	●			45.36	●			66.27	●			110.72	●		
	18.64	●			27.5	●			37.69	●			47.22	●	●		72.62	●			129.77	●		
5.33	37.47	●			46.99	●	●		88.27	●			94.62	●										
	40.64		●		62.87	●			91.44	●			253.37	●										

O'RING - SERIE NO STANDARD

d (mm)		S (mm)		MATERIAL		d (mm)		S (mm)		MATERIAL		d (mm)		S (mm)		MATERIAL		d (mm)		S (mm)		MATERIAL		d (mm)		S (mm)		MATERIAL			
d (mm)	S (mm)	N	S	d (mm)	S (mm)	N	S	d (mm)	S (mm)	N	S	d (mm)	S (mm)	N	S	d (mm)	S (mm)	N	S	d (mm)	S (mm)	N	S	d (mm)	S (mm)	N	S	d (mm)	S (mm)	N	S
2.7	1.2	●		12	3		●	21	1.5	●		31.55	3.72		●	42.2	3	●		60	4	●		90	3	●					
4	1	●		12.5	1.5	●		21	3	●		31.5	3.2	●		43	4		●	60	5	●		91	1.8	●					
4	1.5	●		13.1	1.3	●		22.1	3.6	●		32	3	●		44	2	●		61.8	3	●		94	3	●					
4.47	1.42	●		13.5	3	●		22.2	3.5	●		33.5	4.2	●		44	3	●		62	3.5	●		101	4	●					
4.5	1	●		14	2	●		22.5	2.5	●		34	3	●	●	45	2.5	●		63	3	●		102.5	94.5	●					
5.98	1.99	●		14	2.5		●	22.5	3	●		34.2	2.5	●		45	3	●		63.5	3		●	102.99	3.2	●					
6	2	●		14	3	●	●	23	3	●		35	3.5	●		45	4	●		64	3	●		110	3	●					
6.07	1.63	●		16	2	●		25	4	●		35	4		●	45.2	4		●	65	2.35		●	110	4.5	●					
7	4.5	●		16	2.5	●		26.2	3	●		35.3	3	●		46	3	●		70	3	●		112	4	●					
7.3	2.4	●		16	4		●	28	2	●		36	3	●		46.2	1.9	●		74	3	●		114.5	5	●					
8	1.5	●		16.5	3		●	28	4		●	36.5	3.2	●		46.3	3	●		74	3.35	●		115	2		●				
8	2.4	●		17	2.2	●		28.12	3.5	●		37	3	●		47	4	●		75	3	●		119	3	●					
9	2	●		17.5	6	●		28.2	2.5	●		37.47	3	●		47.3	2	●		76	2.5	●		122	5	●					
9.7	4	●		18	3	●		28.2	5	●		38	3	●		48	4	●		79	1.8	●	●	152	6	●					
10	2.5	●		19.18	2.46	●		29.2	3	●		39	3	●	●	50	4	●		79.5	3		●	168	3.5	●					
10	2.5		●	19.25	2.9	●		30	3.5	●		40	3	●		53.5	3	●		80	3	●		212.15	3	●					
11	2.5		●	20	2	●		30.2	3	●		40	5	●		55	2	●		82	3.5	●		320	8	●					
11.3	2.4	●		20	2.5	●		30.5	3.5	●		42	3	●		56.4	2	●		85	3	●									
12	2.5	●		20	4	●		30.5	3.8	●		42	4	●		58	2	●		85.5	3.35	●									

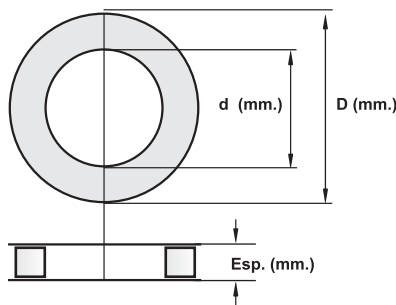

- > Diámetro interior d (mm)
- > Diámetro exterior D (mm)
- > Sección S (mm)
- > Diámetro interno d (mm)
- > Diámetro externo D (mm)
- > Corte S (mm)
- > Inner diameter d (mm)
- > Outer diameter D (mm)
- > Section S (mm)

ANILLOS

d (mm)	D (mm)	S (mm)	Mat.	d (mm)	D (mm)	S (mm)	Mat.	d (mm)	D (mm)	S (mm)	Mat.	d (mm)	D (mm)	S (mm)	Mat.	d (mm)	D (mm)	S (mm)	Mat.				
6	3	3	N	10	6	1	N	15	11	3	N	33	22	8	N	46	34	2	N	73	65	5	N
8	4	1	N	15	6	1	N	14,5	11,5	4	N	30	24	3,9	N	46,5	38,5	4	N	82	73	9,7	N
13,8	5	7,8	N	13,8	6,4	8	N	30	15,5	12	N	21	35	13	N	56,5	66,5	6	N	91	82,2	4,7	N
9	5	9,5	N	7,2	11	6	N	24	17	9	N	47,5	41,5	7	N	57	42	3	N	104,2	95	3	N



taranto



Retenes Taranto. Un sello de garantía

El permanente desafío que presenta la evolución de los motores de combustión actuales para asegurar el sellado de sus componentes requiere del desarrollo y aplicación de tecnología moderna y eficiente en la fabricación de los retenes. La constante actividad de nuestro Departamento de Ingeniería, aplicada al desarrollo e investigación de nuevos materiales y componentes para lograr la mejor performance de nuestros productos, acompañada de la realización de ensayos de vida y exigentes pruebas específicas que garantizan el perfecto desempeño en los distintos medios funcionales y la utilización de modernas técnicas de diseño aplicada a la construcción de nuevos labios y perfiles hidrodinámicos, permite ofrecer al mercado productos que superan las necesidades de estanqueidad del motor.



1 - NUEVOS PERFILES

Facilita el montaje y asegura el agarre.

2 - POSICION PREFERENCIAL DEL LABIO

Permite trabajar el labio en posiciones no utilizadas del eje.

3 - MODERNOS DISEÑOS

Permite trabajar el labio en una parte del eje no utilizable hasta el momento.

1

2

3









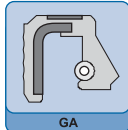
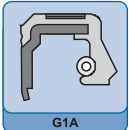
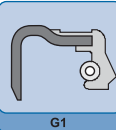
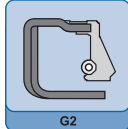

RETENES - MATERIALES

Oil Seal - Materials

	ASTM D1418	ISO 1629	TARANTO	TEMPERATURA TEMPERATURE
<p>SILICONA Material para aplicaciones de baja y alta temperatura, muy usado en motores de elevada exigencia y en transmisiones automáticas. No recomendada para aceites EP (Extrema Presión).</p> <p>SILICONE Material para aplicação em baixas e altas temperaturas, muito usado em motores de elevada exigência. Não é recomendada para óleos EP (Extrema Pressão).</p> <p>SILICONE Material for low and high temperature applications, highly recommended for engines and automatic transmission. It should not be used for EP oils (Extreme Pressure).</p>	VMQ	MVQ	S	-50°C a +180°C
<p>NITRÍLICO Es el material más comúnmente utilizado en sellado para aplicaciones generales. Buena resistencia a la abrasión y a la acción de aceites y grasas minerales.</p> <p>NITRILICA É o material mais comumente utilizado em vedação para aplicações gerais. Tem boa resistência ao atrito e a ação de óleos e graxas minerais.</p> <p>NITRILE It is the most commonly used sealing material for general applications. Good resistance to abrasion and to mineral oils and greases.</p>	NBR	NBR	N	-35°C a +110°C
<p>POLIACRÍLICO Recomendado para aplicaciones en motor y especialmente en transmisión con aceites EP. Deformación permanente más elevada.</p> <p>POLIACRÍLICO Recomendado para aplicações em motores e especialmente em transmissões com óleo EP. Deformação permanente mais elevada.</p> <p>ACRYLIC (POLYACRYLATE) Highly recommended for engines and especially in transmission with EP oils. Higher permanent set.</p>	ACM	ACM	P	-30°C a +150°C
<p>FLUORELASTOMERO Compuesto para altas exigencias con mejor resistencia a altas temperaturas y ataques químicos. Ofrece duración en servicio muy superior, pero a costo más elevado.</p> <p>FLUORELASTÓMERO Composto para altas exigências com melhor resistência a altas temperaturas e ataques químicos. Oferece duração em serviço muito superior, porém a um custo mais elevado.</p> <p>FLUORELASTOMERS Compound for high demands with better resistance to high temperatures and chemical aggressions. It grants a better duration in service but at higher costs.</p>	FKM	FPM	V	-30°C a +200°C
<p>POLITETRAFLUORETILENO Usos de elevada temperatura, gran ataque químico y severas condiciones de fricción.</p> <p>POLITETRAFLUORETILENO Utilizado em ambientes com altas temperaturas e elevado ataque químico, e em condições severas de atrito.</p> <p>POLYTETRAFLUORETHYLENE High temperature uses, great chemical attack and severe friction conditions.</p>	PTFE	PTFE	T	-80°C a +250°C
<p>FLUORELASTOMERO / POLITETRAFLUORETILENO Compuesto especial desarrollado por Taranto (Viflón) para altas exigencias de temperatura, ataque químico e importantes condiciones de fricción. Es la elección ideal entre el tipo V y el tipo T.</p> <p>FLUOROELASTOMER / POLITETRAFLUORETILENO Composto especial desenvolvido pela Taranto (Viflón) para os requisitos de alta temperatura, gravura e importantes Condições por atrito. É a escolha ideal entre o tipo V e T-type</p> <p>FLUOROELASTOMER / POLYTETRAFLUORETHYLENE Special compound developed by Taranto (Viflón) for high temperature requirements, chemical attack and important conditions of friction . Is the ideal choice between the V type and T-type</p>	FKM PTFE	FKM PTFE	T	-30°C a +200°C

DESCRIPCIÓN - TIPOS DE RETENTES RADIALES

Types oil seal - description

GA	Goma armada Exterior borracha Rubber case	G1A	Exterior goma metal Exterior metal borracha Outer rubber metal	G1	Exterior metal Exterior metálico Outer metal			
G2	Blindado Blindado Armoured	RI	Roscado izquierdo Rosca esquerda Left Threaded	RD	Roscado derecho Rosca direita Right Threaded			
SR	Sin resorte Sem mola Without spring	LG	Labio guardapolvo Láblio guarda-pó Dust Lip	HD	Hélice derecha Hélice direita Right helix			
HI	Hélice izquierda Hélice esquerda Left helix	ESP	Especial Especial Special	BI	Bidireccional Bidireccional Bi-directional			

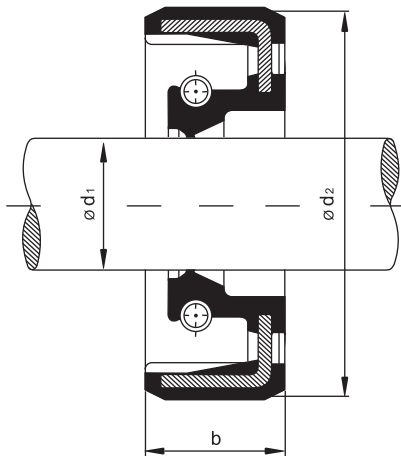

- > Diámetro de Eje (d1)
- > Altura (b)
- > Alojamiento (d2)
- > Diâmetro do eixo (d1)
- > Altura (b)
- > Alojamento (d2)
- > Shaft diameter (d1)
- > Height housing (b)
- > Housing Bore (d2)

RETENES POR DIÁMETRO DE EJE					MATERIAL							RETENES POR DIÁMETRO DE EJE					MATERIAL					
CODIGO	EJE	ALOJAM.	ALT.	TIPO	N	S	P	V	T	Vf		CODIGO	EJE	ALOJAM.	ALT.	TIPO	N	S	P	V	T	Vf
R300347	7,90	16,00	6	GA	●							R230448	24,00	46,50	10	ESP		●				
R550614	8,10	14,30	4,2	U'RING				●				R250156	25,00	35,00	7	GA	●					
R550447	8,40	16,00	6,5	GA	●							R280415	25,00	40,00	8	GALG-BI	●					
R460215	9,50	16,00	4	GALGSR	●							R560113	25,00	42,00	7	GALGHD		●	●			
R550515	12,70	25,40	6,5	GAHI			●					R240415	26,00	42,00	8	G1ALGHD		●	●			
R223543	13,00	21,90	5/6,5	ESP-GADUO						●		R550660	26,00	42,00	8/17	EGALG	●					
R240048	13,00	26,00	7	GALG	●							R350315	26,00	45,00	10	G1	●					
R550051	13,00	26,00	9	GALG	●							R902115	26,00	49,0	9.5/11	ESP	●					
R250148	14,00	24,00	7	ESP	●							R270515	27,00	37,00	7	G1ALGHD			●			
R550451	15,00	26,00	7	GALG	●							R860012	27,00	39,50	7	GALGHD		●				
R300748	15,50	28,00	6/15	ESP	●							R231313	27,00	42,00	8	G1ALGHD			●			
R300048	15,70	23,81	4,76	GA SR	●							R470813	27,00	47,00	7	GALGHD			●			
R550648	16,00	22,80	4,8	GA	●							R550951	27,95	56,00	10	GALGHD		●				
R250448	16,00	24,60	9/20	ESP	●							R570351	27,95	70,00	10	GALGHD		●				
R450348	17,00	23,00	7	ESP	●							R320013	28,00	38,00	7	GALGHD		●	●			
R910514	17,00	28,00	7	GALG		●						R300351	28,00	40,00	8	GALGHD	●					
R910515	17,00	28,00	7	GALG		●						R570913	28,00	42,00	5	GALGHD			●			
R300749	17,00	28,00	7/10	GALGHD	●							R222313	28,00	42,00	7	GALGHI			●			
R550450	17,00	28,00	7/13	GAHD	●							R450557	28,00	45,00	8	GAHD		●				
R280215	17,50	32,00	6	GALGHD	●	●	●					R580013	28,00	47,00	5,5	GALGHD			●			
R220649	20,00	35,00	7/10,5	GAHD			●					R250151	28,00	47,00	8	GAHD	●					
R240949	21,00	32,00	7,5	G1LGHD	●							R510012	28,50	41,25	6	GALGHD			●			
R232430	21,00	35,22	9	ESP			●					R300051	28,58	41,20	6,2	G1HD	●					
R300751	21,50	40,00	7	GAHD			●					R250660-1	29,80	50,00	10/13,5	G1ALGHD			●			
R250652	22,00	35,00	8	GALG	●							R250660	29,80	52,00	10/13,5	G1ALGHI			●			
R250451	22,00	40,00	7/8,5	G2LGHD	●							R200849	29,90	45,00	7	G1HD			●			
R560114	22,00	45,00	7	GALGHI			●	●				R460760	29,90	47,00	11,3	GALGRD c/f			●			
R220349	22,10	40,00	12/17	GALGHD	●							R550615	30,00	40,00	7	GAHD	●	●	●			
R400213	22,22	34,92	6,35	GA	●							R860013	30,00	40,00	7	GA-B		●				
R400215	22,22	35,70	9,52	ESP-RD	●							R260113	30,00	42,00	7	GALGHD			●	●		
R260251	22,80	40,00	7/8,5	G2LGHD			●					R550413	30,00	42,00	8	GAHI	●	●				
R250457	23,00	37,00	13,5	ESP			●					R150012	30,00	42,04	8	GALGHD	●					
R550550	24,00	36,00	8/12	GAHD	●							R260112	30,00	43,00	8	G1ALGHD			●	●		

c/f Con Feltro/With Felt



RETENES RADIALES Oil Seal Catalog

RETENES POR DIÁMETRO DE EJE					MATERIAL								RETENES POR DIÁMETRO DE EJE					MATERIAL							
CODIGO	EJE	ALOJAM.	ALT.	TIPO	N	S	P	V	T	VF	CODIGO		EJE	ALOJAM.	ALT.	TIPO	N	S	P	V	T	VF			
R950011	58,00	74,00	9,5	GALGHI								R970011	75,00	100,00	13	GALGRI									
R310458	58,95	76,00	9	G1SRLG								R700212	75,00	100,00	17	GALGHD									
R550655	60,00	70,00	9,1	ESP								R200811	75,90	95,00	11,3	GALGH									
R500211-1	60,00	75,00	5	EXPAN								R241911	76,00	92,00	10	GALGRI									
R581812	60,00	75,00	7	GALGRD								R220111	76,20	95,22	9,32	GARI									
R990011	60,00	75,00	8	GALGHI								R510411	76,20	95,25	9,5	GALGHD									
R950711	60,00	78,00	10	GALGHI								R271511	78,00	100,00	9	GALGSRRI									
R940011	60,00	80,00	8	GALGHI								R460511	78,00	100,00	10	G1ALGHI									
R330012	60,30	82,50	11	G1HD								R310412	78,00	100,00	13	GALGHD									
R400012	60,32	79,36	9,5	GALGHD								R351012	78,00	104,00	11	GASRRD C/F									
R320111	60,45	76,18	10	GALGHI								R860011	79,00	126,00	1,25	ESPFI									
R260950	63,00	69,50	11	ESP								PR320011	79,00	-	16	PORTA									
R870012	63,50	79,50	9	G1ALGRD								R330311	79,30	99,00	9,8	GALGHI									
R200011	64,00	78,00	12	2 PARTES								PR340111	79,30	-	-	PORTA									
R200011-1	64,00	78,00	12	2 PARTES								R300611	79,38	95,25	11,11	GAHI									
R200011-2	64,00	78,00	12	EXPAN								R520811	80,00	96,00	9	GALGRI									
R450411-1	64,00	80,00	5	EXPAN								R910511	80,00	96,00	9	GALGHI									
R250111	64,00	80,00	8	G1ALGHI								R950611	80,00	96,00	9	GALGRI									
R250811	64,00	80,00	8	G1ALGHD								R240411	80,00	98,00	10	G1ALGRI									
R700112	64,00	85,00	12	GAHD								R570011	80,00	100,00	8	GALGRI									
R470012	64,00	88,00	6	GALGHD								R250211	80,00	100,00	10	GALGHI									
PR260911	64,00	-	-	PORTA								R810115	80,00	100,00	12	G1LG-BI									
R650112	65,00	85,00	13	G1ALGHD								R950411	80,00	100,00	12	GALGHI									
R350212	65,00	90,00	15	G1LGHD								R550811	80,00	100,00	13	GARI									
R330312	66,67	85,70	10	GALGRD								R902311	80,00	100,00	13	GALGHI									
R320012	66,67	89,30	10	GALGRD								R970311	80,00	105,00	13	GALGHI									
R330212	66,70	88,80	11/12,5	G1ALGHD								PR320911	80,00	-	-	PORTA									
R350957	68,00	85,00	10	GALGHD								PR340314	80,00	-	-	PORTA									
R360057	68,00	85,00	10	GALG								R300711	82,00	105,00	12	GALGHI									
R581813	70,00	85,00	7	GALGRD								R902111	84,00	104,00	11	GALGRI									
R260011	70,00	85,00	8	G1ALGHI								R903411	84,00	117,00	8,5	GALGRI									
R570511	70,00	86,00	8	GALGHI								R560111	85,00	105,00	8	GALGRI									
R971511	70,00	88,00	11	-								R910611	85,00	105,00	10	GAHI									
R220311	70,00	90,00	10	GAHI								R560611	85,00	105,00	11	GALGRI									
R270112	70,00	90,00	10	GALGHD								R220411	85,00	105,00	12	GALGRI									
R550411	70,00	90,00	10	GALGHI								PR221711	85,00	-	-	PORTA									
R800012	70,00	90,00	15	G1LGHD								PR230211	85,00	-	-	PORTA									
PR270112	70,00	-	-	PORTA								PR231211	85,00	-	-	PORTA									
R950311	72,00	96,00	9	GALGRI								R300911	85,70	100,00	5,5	E-GARI									
R270511	74,00	88,00	8	G1ALGRI								R300011	85,70	102,62	9,73	GAHI									
R260111	74,00	90,00	10	G1ALGRI								R240311	85,90	104,00	11	GALGRI									
PR270511-1	74,00	-	-	PORTA								R300911-1	86,00	100,00	5,5	EXPAN									
PR270711	74,00	-	-	PORTA								R280211	87,00	100,00	8,5	GALGRI									
PR271911	74,00	-	-	PORTA								R320311	88,00	108,00	10	GALGRI									
R870212	75,00	93,00	9/10	G1ALGRD								R301711	88,00	108,00	11	GAHI									
R350858	75,00	95,00	13	GALG								PR302211	88,00	-	-	PORTA									
R350612	75,00	100,00	12	G1LGHD								R420611	88,90	105,00	9,5	GARI									

c/f Con Fieltro/With Felt



taranto



Junta Tapa de Cilindros Taranto.

Las juntas están diseñadas para superar las exigencias de presión y temperatura que producen los motores de última generación.

- ▶ Eliminación del retorque en juntas 07 y 08.
- ▶ Mayor resistencia mecánica y térmica.
- ▶ Compuestos sellantes especiales que aseguran la máxima estanqueidad.
- ▶ Superficie sellante antiadherente que no daña las partes metálicas del motor.
- ▶ Ahorro de mano de obra, evita trabajos adicionales.
- ▶ Utilización de materiales ecológicos.







JUNTA TAPA DE CILINDROS - LINEA PESADA

Head Gaskets - Heavy Duty

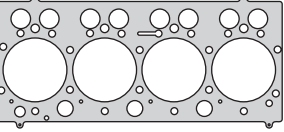



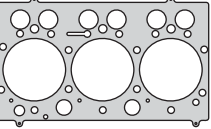

AGCO / SISU

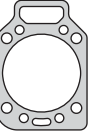

423108 	Código	Ø	≠	Kit Bulón	Modelo
	423108	121.0	1.30		Massey Ferguson MF4292, MF4297, Challenger - Valtra A950/A990 (4x2, 4x4), BM100/BM110 (4x2, 4x4) - (4 Cilindros)
					Motor
					4400cc. 420D/DS Agco Sisu Power 106/129HP Ø108 - DIESEL (423100-R MLS)  pág. 02

423208 	Código	Ø	≠	Kit Bulón	Modelo
	423208	121.0	1.30		MF Case-IH CS - Valtra A65/A75/305/355/365/405/455/465 - (3 cilindros) CS/CVX120/130/150 - CVX1135/1145/1155/1170 - Optima 440F Challenger 565/600/700 - Valtra 8000 - (6 cilindros)
					Motor
					3300cc. 320D/DS 33/69HP Ø108 - DIESEL (423000-R MLS)  pág. 01 6600cc. 620D/DS 147/189HP Ø108 - DIESEL (423200-R MLS)  pág. 03

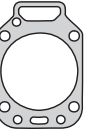

AGRALE

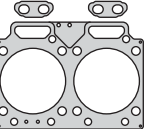

310407 	Código	Ø	≠	Kit Bulón	Modelo
	310407	110.0	1.45	B330800  (HAS17038)	Camión TX 1600 1983/...
					Motor
					2942cc. D229-3 72HP Ø102 - DIESEL (330800-R)  pág. 116

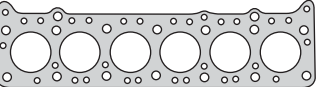

330407 	Código	Ø	≠	Kit Bulón	Modelo
	330407	113.4	1.45		7000 - 7500 - 8500
					Motor
					4300cc. 4.10 X10 90HP - 4.10T/TCA 133/167HP Ø103 - DIESEL (330400-R)  pág. 113

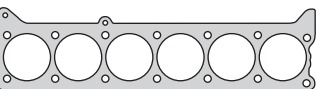

331208 	Código	Ø	≠	Kit Bulón	Modelo
	331208	113.5	1.30		8500 - 9200
					Motor
					4800cc. 4.12TCE Commom Rail 150/180HP Ø105 - DIESEL (331200-R MLS)  pág. 117

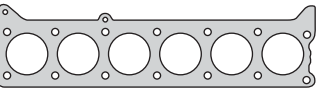

BEDFORD

210005 	Código	Ø	≠	Kit Bulón	Modelo
	210105	101.0	1.85		J6 1961/71
					Motor
					4927cc. 300D 97HP Ø98.3 - DIESEL (210000-R)  pág. 05

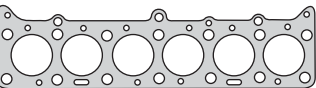
210105 	Código	Ø	≠	Kit Bulón	Modelo
	210105	110.0	1.90		350H - C60 - 714 1971/79
					Motor
					5755cc. 350D - CD600 137HP Ø106.36 - DIESEL (210100-R)  pág. 06

210205 	Código	Ø	≠	Kit Bulón	Modelo
	210205	101.0	1.90		C50 Turbo 1971/79
					Motor
					4927cc. 300DX 97HP Ø98.3 - DIESEL (210200-R)  pág. 07

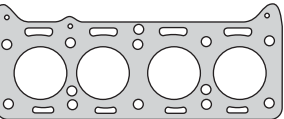
210305 	Código	Ø	≠	Kit Bulón	Modelo
	210305	101.5	1.70		J6 1956/61
					Motor
					4927cc. 300D 97HP Ø98.3 - DIESEL (210300-R)  pág. 08

210805 	Código	Ø	≠	Kit Bulón	Modelo
	210805	101.5	1.70		C14 - J17 - J27 - J37 1962/64
					Motor
					3285cc. 200D 62HP Ø98.3 - DIESEL (210800-R)  pág. 09



JUNTA TAPA DE CILINDROS - LINEA PESADA

Head Gaskets - Heavy Duty

CATERPILLAR

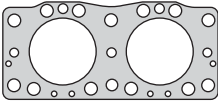
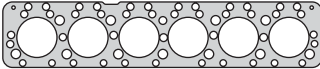
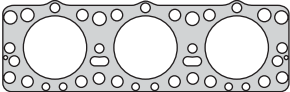
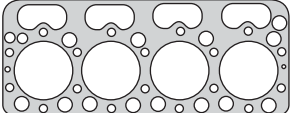
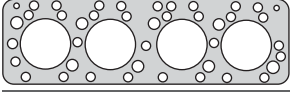
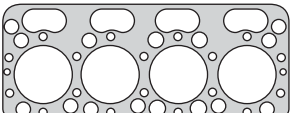
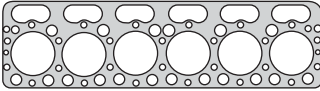
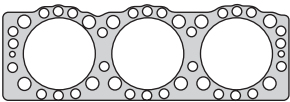
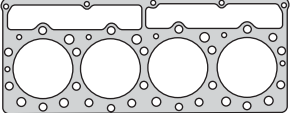
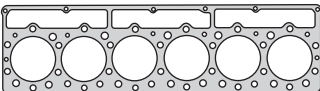
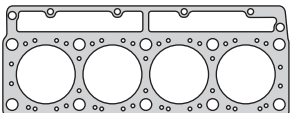
960532 	Código	Ø	✕	Kit Bulón	Modelo	Caterpillar Motoniveladora
	960532	159.0			Motor	D339 - D17 - 2 cilindros - DIESEL
960534 	Código	Ø	✕	Kit Bulón	Modelo	Caterpillar
	960534	128.0			Motor	D318 - 12 70 D - 6 cilindros - DIESEL
960535 	Código	Ø	✕	Kit Bulón	Modelo	Caterpillar
	960535	160.0			Motor	D8 14A - 46A D342 - 3 cilindros - DIESEL
960541 	Código	Ø	✕	Kit Bulón	Modelo	Caterpillar
	960541	127.0			Motor	9 44/43 A950 D330 - 4 cilindros - DIESEL
960542 	Código	Ø	✕	Kit Bulón	Modelo	Caterpillar
	960542	127.0			Motor	D315 112 34 - 4 cilindros - DIESEL
960543 	Código	Ø	✕	Kit Bulón	Modelo	Caterpillar
	960543	114.0			Motor	922 59A D6 - 4 cilindros - DIESEL
960544 	Código	Ø	✕	Kit Bulón	Modelo	Caterpillar
	960544	127.0			Motor	12 99E 966 - 334 - 6 cilindros - DIESEL
960547 	Código	Ø	✕	Kit Bulón	Modelo	Caterpillar
	960547	178.0			Motor	D9 D353 - 3 cilindros - DIESEL
960548 	Código	Ø	✕	Kit Bulón	Modelo	Caterpillar Motoniveladora
	960548	133.0			Motor	6969cc. 3304 Ø120.65 - 4 cilindros - DIESEL
960549 	Código	Ø	✕	Kit Bulón	Modelo	Caterpillar Motoniveladora
	960549	133.0			Motor	10453cc. 3306 Ø120.65 - 6 cilindros - DIESEL
960550 	Código	Ø	✕	Kit Bulón	Modelo	Caterpillar
	960550	109.0			Motor	3054 - 4 cilindros - DIESEL

JUNTA TAPA DE CILINDROS - LINEA PESADA

Head Gaskets - Heavy Duty



CATERPILLAR

960551

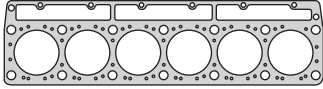

Código	Ø	≠	Kit Bulón	Modelo
960551	109.0			Caterpillar
				Motor

3056 - 6 cilindros - DIESEL

CHEVROLET

210005

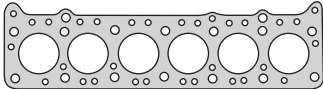

Código	Ø	≠	Kit Bulón	Modelo
210105	101.0	1.85		J6 1961/71
				Motor

4927cc. 300D 97HP Ø98.3 - DIESEL (210000-R) pág. 05

210105

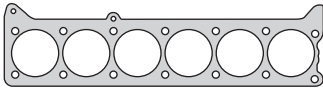

Código	Ø	≠	Kit Bulón	Modelo
210105	110.0	1.90		350H - C60 - 714 1971/79
				Motor

5755cc. 350D - CD600 137HP Ø106.36 - DIESEL (210100-R) pág. 06

210205

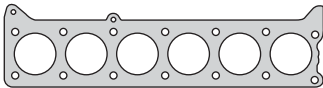

Código	Ø	≠	Kit Bulón	Modelo
210205	101.0	1.90		C50 Turbo 1971/79
				Motor

4927cc. 300DX 97HP Ø98.3 - DIESEL (210200-R) pág. 07

210305

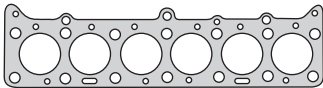

Código	Ø	≠	Kit Bulón	Modelo
210305	101.5	1.70		J6 1956/61
				Motor

4927cc. 300D 97HP Ø98.3 - DIESEL (210300-R) pág. 08

210805

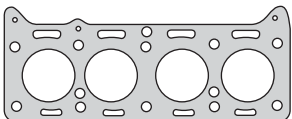

Código	Ø	≠	Kit Bulón	Modelo
210805	101.5	1.70		C14 - J17 - J27 - J37 1962/64
				Motor

3285cc. 200D 62HP Ø98.3 - DIESEL (210800-R) pág. 09

410605 - 410607

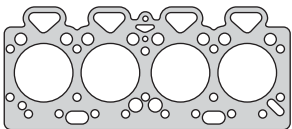

Código	Ø	≠	Kit Bulón	Modelo
410605	104.0	1.70		GM D20
410607	104.0	1.70		GM D10/20/40 Aspirado Turbo
				Motor

3860cc. Q20B4 Iny. Directa 70HP Ø98.4 - DIESEL (401000-R) pág. 129
3860cc. Q20B4.236 Iny. Directa 70HP Ø98.4 - DIESEL (410600-R) pág. 142

410907

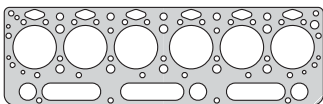

Código	Ø	≠	Kit Bulón	Modelo
410907	107.0	1.50		GM Brasil D60/D70
				Motor

5840cc. 6-357 Agrícola 91HP - Industrial 108HP Ø104.14 - DIESEL (410900-R) pág. 145

CIMARRON

210405

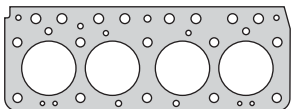

Código	Ø	≠	Kit Bulón	Modelo
210405	101.0	1.40		3300D 1976/85
				Motor

3285cc. 3300D 88HP Ø98.3 - DIESEL (210400-R) pág. 11

210505

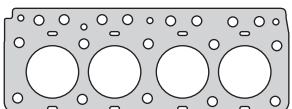

Código	Ø	≠	Kit Bulón	Modelo
210505	101.0	1.40		3300D 1986/...
				Motor

3283cc. 3300D 89HP Ø98.42 - DIESEL (210500-R) pág. 12



JUNTA TAPA DE CILINDROS - LINEA PESADA

Head Gaskets - Heavy Duty

CIMARRON

210605

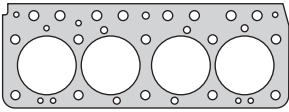

Código	Ø	≠	Kit Bulón	Modelo
210605	109.5	1.40		3800D 1979/85

Modelo 3800D 1979/85

Motor **3840cc.** 3800D 99HP Ø106.4 - DIESEL (210600-R) pág. 13

210705

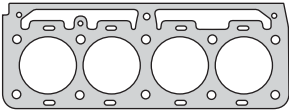

Código	Ø	≠	Kit Bulón	Modelo
210705	109.5	1.40		3800D 1986/...

Modelo 3800D 1986/...

Motor **3840cc.** 3800D 99HP Ø106.4 - DIESEL (210700-R) pág. 14

CUMMINS

800808

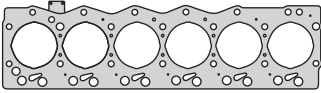

Código	Ø	≠	Kit Bulón	Modelo
800808	105.0	1.20	B800800	ISB 2004/...

Modelo ISB 2004/...

Motor **5883cc.** ISBe 6275HP Ø102 - DIESEL (800800-R) pág. 61

870007

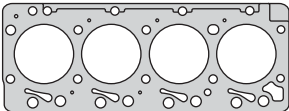

Código	Ø	≠	Kit Bulón	Modelo
870007	106.0	1.60	B870000	Serie B - F100 1998/... - F4000 2000/... - Cargo 915 - Euro II

Modelo Serie B - F100 1998/... - F4000 2000/... - Cargo 915 - Euro II

Motor **3900cc.** 4B 100HP - 4BT/BTA 130HP Ø102 - DIESEL (870000-R) pág. 15

870107

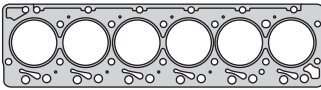

Código	Ø	≠	Kit Bulón	Modelo
870107	106.0	1.60	B870100	Serie B - F14000 - Turbo - F4000 1999/... - 1416 Euro I Dodge Truck 359 1989/93 - Ram 2007/...

Modelo Serie B - F14000 - Turbo - F4000 1999/... - 1416 Euro I
Dodge Truck 359 1989/93 - Ram 2007/...

Motor **5883cc.** 6B 330HP Ø102 - DIESEL (870100-R) pág. 17

5900cc. 6B 180HP - 6BT/BTA 205HP Ø102 - DIESEL (870100-R) pág. 17

870207

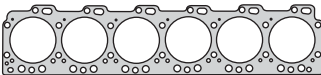

Código	Ø	≠	Kit Bulón	Modelo
870207	120.0	1.50	B870200	Serie C - Bus - Camión - Agrícola Cargo 1722/1730/2625 1998/... - F14000 1999/...

Modelo Serie C - Bus - Camión - Agrícola
Cargo 1722/1730/2625 1998/... - F14000 1999/...

Motor **8300cc.** 6C 254HP - 6CT/CTA 294HP Ø114 - DIESEL (870200-R) pág. 19

870307

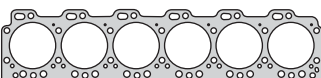

Código	Ø	≠	Kit Bulón	Modelo
870307	120.0	1.50	B870200	Serie C - Bus - Cargo 1722 - 1730 - 2625 1998/... - F14000

Modelo Serie C - Bus - Cargo 1722 - 1730 - 2625 1998/... - F14000

Motor **8300cc.** 6C 254HP - 6CT/CTA 294HP Ø114

870508

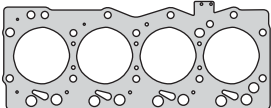

Código	Ø	≠	Kit Bulón	Modelo
870508	105.0	1.10	B870500	Bus - Agrale - Euro III/IV - Electrónico 2003/...

Modelo Bus - Agrale - Euro III/IV - Electrónico 2003/...

Motor **3900cc.** ISBe 150HP Ø102 - DIESEL (870500-R) pág. 21

870608

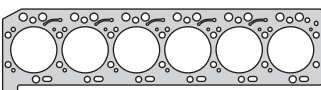

Código	Ø	≠	Kit Bulón	Modelo
870608	123.5	1.80	B870200	Cummins Serie C - Ford 2632E/2932E/4432E/4532E/5032E Cargo 2003/... - VW 17220/17300/17310/18310/19320/26320 17250E/19320E/24250E - Bus 17260EOT/18320EOT 2003/...

Modelo Cummins Serie C - Ford 2632E/2932E/4432E/4532E/5032E
Cargo 2003/... - VW 17220/17300/17310/18310/19320/26320
17250E/19320E/24250E - Bus 17260EOT/18320EOT 2003/...

Motor **8270cc.** ISCe 6 24V Serie C 1832/2632 315HP Ø114 - DIESEL (870600-R) Pág 22

DODGE

320807

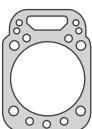

Código	Ø	≠	Kit Bulón	Modelo
320807	110.0	1.20		Camión 1978/...

Modelo Camión 1978/...

Motor **5100cc.** D225-6 102HP Ø95 - DIESEL (440100-R) pág. 120

JUNTA TAPA DE CILINDROS - LINEA PESADA

Head Gaskets - Heavy Duty



DODGE

400005 - 400007 - 400008

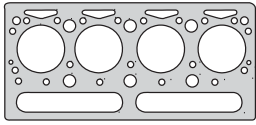

Código	Ø	≠	Kit Bulón
400005	92.5	1.40	B400000
400007	92.5	1.40	(HAS19038)
400008	92.5	1.15	

Modelo D100 - D200 1987/...

Motor **3336cc.** 4.203-P4-192Z 71HP Ø91.49 - DIESEL (400000-R) pág. 121

400107 - 400108

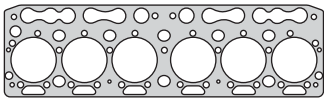

Código	Ø	≠	Kit Bulón
400107	93.0	1.40	
400108	93.0	1.15	

Modelo DP 400/500 1964/...

Motor **5004cc.** 6.305 Cadenero 100HP Ø91.44 - DIESEL (400100-R) pág. 122

400207 - 400208

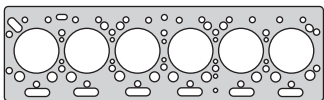

Código	Ø	≠	Kit Bulón
400207	104.0	1.50	B400200
400208	104.0	1.30	(HAS19038)

Modelo DP 600/800 1968/...

Motor **5798cc.** 6.354-2 140HP Ø98.47 - DIESEL (400200-R) pág. 123

400407 - 400408

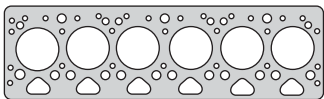

Código	Ø	≠	Kit Bulón
400407	104.0	1.50	B400200
400408	104.0	1.45	(HAS19038)

Modelo D600 - D800 1976/...

Motor **5798cc.** 6.354-4 Turbo 172HP Ø98.42 - DIESEL (400400-R) pág. 125

400907

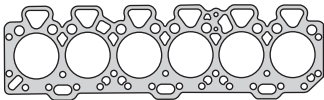

Código	Ø	≠	Kit Bulón
400907	104.0	1.45	B400200 (HAS19038)

Modelo DP 600 - DP 800

Motor **5798cc.** 6.354-1 135HP Ø98.43 - DIESEL (400900-R) pág. 128

410907

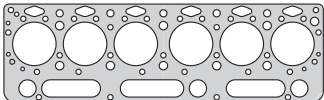

Código	Ø	≠	Kit Bulón
410907	107.0	1.50	

Modelo P700D - P900

Motor **5840cc.** 6-357 Agrícola 91HP - Industrial 108HP Ø104.14 - DIESEL (410900-R) pág. 145

870107

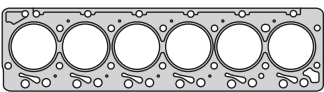

Código	Ø	≠	Kit Bulón
870107	106.0	1.60	B870100

Modelo Dodge Truck 359 1989/93 - Ram 2007/...

Motor **5883cc.** 6B 330HP Ø102 - DIESEL (870100-R) pág. 17

DYNAPAC

310407

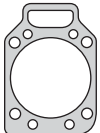

Código	Ø	≠	Kit Bulón
310407	110.0	1.45	B330800 (HAS17038)

Modelo Cilindro Vibratorio CHF 44 1983/...

Motor **2942cc.** D229-3 72HP Ø102 - DIESEL (330800-R) pág. 116

FIAT TRACTOR - CAMION

310407

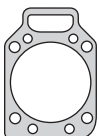

Código	Ø	≠	Kit Bulón
310407	110.0	1.45	B310400 B310500 (HAS17038)

Modelo Escavadora FB80
Tractor S90 - FE105 - FA120 - FE105B

Motor **3922cc.** D229-4 96HP Ø102 - DIESEL (310400-R) pág. 107
5883cc. D229-6 145/160HP Ø102 - DIESEL (310500-R) pág. 109

320807

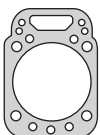

Código	Ø	≠	Kit Bulón
320807	110.0	1.20	

Modelo 850E (4 cilindros)
Tractor AD7B - 980E - S90 (6 cilindros)

Motor **2977cc.** D225-4 **3400cc.** D225-4 68HP Ø95 - DIESEL (440000) pág. 119
5100cc. D225-6 102HP Ø95 - DIESEL (440100-R) pág. 120



JUNTA TAPA DE CILINDROS - LINEA PESADA

Head Gaskets - Heavy Duty

FIAT TRACTOR - CAMION

700007 - 700008

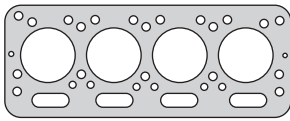

Código	Ø	≠	Kit Bulón	Modelo
700007	109.0	1.80		Tractor Someca 1965/74
700008	109.0	1.80		Motor 4156cc. M45 - 450 - 55 Super Son Ø105 - DIESEL (700000) pág. 39

700108

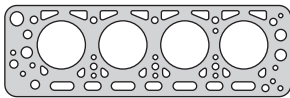

Código	Ø	≠	Kit Bulón	Modelo
700108	126.5	1.80		Tractor 1962/69
				Motor 6872cc. 780 - R - AE Ø125 - DIESEL (700100) pág. 40

700207 - 700208

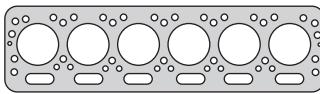

Código	Ø	≠	Kit Bulón	Modelo
700207	114.5	2.00		Tractor - CP3 1972/80
700208	114.0	1.86		Camión 1964/83
				Motor 7412cc. 840 - 900 - 1100 - CP3 - 900E 165HP Ø110 - DIESEL (700200) pág. 41
				7412cc. 673N - CP 840 - 900 Ø110 - DIESEL (710100) pág. 49

700308

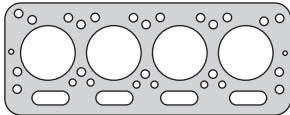

Código	Ø	≠	Kit Bulón	Modelo
700308	112.5	1.80		Tractor Someca - CN3 1961/70
				Someca M45/M50 - Super Som 55/46A - Tigrotto 1969/...
				Motor 3421cc. 650 - 700 Ø110 - DIESEL (700300) pág. 42
				4397cc. CO3 Ø108 - DIESEL (700300) pág. 42

700408

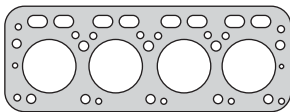

Código	Ø	≠	Kit Bulón	Modelo
700408	104.0	1.80		Tractor Someca - Leoncino 1950/...
				Motor 3456cc. DA - 50 - 40 Ø100 - DIESEL (700400) pág. 43

700507 - 700508

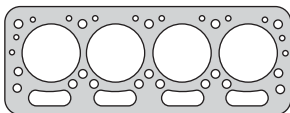

Código	Ø	≠	Kit Bulón	Modelo
700507	118.0	2.00		Tractor - CO3 1971/80
700508	118.0	1.86		
				Motor 5401cc. 700E - 800E - CO3 - 640 - 740 90/106HP Ø115 - DIESEL (700500) pág. 44

700605

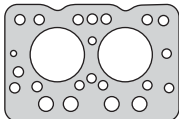

Código	Ø	≠	Kit Bulón	Modelo
700605	87.0	1.40		Tractor U25 1957/62 - Tractor 211R 1962/65
				Motor 1135cc. U25 - 211R - CD Ø85 - DIESEL (700600) pág. 45

700708

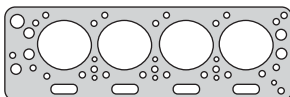

Código	Ø	≠	Kit Bulón	Modelo
700708	126.0	1.80		Tractor 1955/...
				Motor 6546cc. 60 RL Ø122 - DIESEL (700700) pág. 46

700807 - 700808

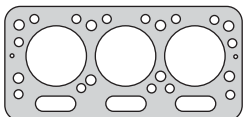

Código	Ø	≠	Kit Bulón	Modelo
700807	114.0	2.00		Tractor 400 E.V.U - 500 - Super 600E - 480 1969/80
700808	114.0	1.86		
				Motor 3421cc. CN3 Ø110 - DIESEL (700800) pág. 47
				3705cc. CN4 Ø110 - DIESEL (700800) pág. 47

700908

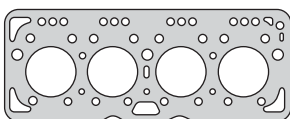

Código	Ø	≠	Kit Bulón	Modelo
700908	86.0	1.65		Tractor 411R - 411T - 431R 1959/85
				Motor 2270cc. 615 40HP Ø85 - DIESEL (700900) pág. 48

710205

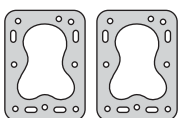



Código	Ø	≠	Kit Bulón	Modelo
710205	79.0	1.40		Motor Arranque - Tractor 1955/74
				Motor 665cc. Motorino 55/60/788R Ø75 - DIESEL (710200) pág. 50

JUNTA TAPA DE CILINDROS - LINEA PESADA





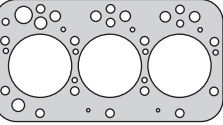
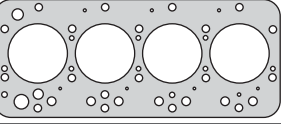
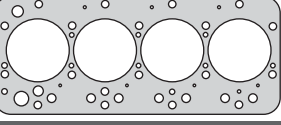
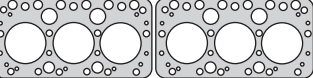





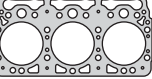
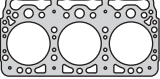

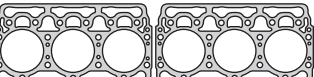
Head Gaskets - Heavy Duty

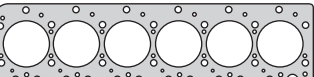

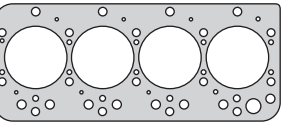
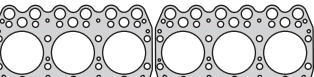
FIAT TRACTOR - CAMION

	Código	Ø	≠	Kit Bulón	Modelo	Tractor
	710305	120.5	1.40		Motor	2592cc. 480-540T 100HP - DIESEL
	Código	Ø	≠	Kit Bulón	Modelo	Tractor - Camiones
	710405	102.0	1.70		Motor	3455cc. 640-670-680 100HP - DIESEL
	Código	Ø	≠	Kit Bulón	Modelo	Tractor - Camiones 780 - 780 DT - 765C - 766 - 855
	710505	106.0	1.40		Motor	3663cc. 780/780DT Ø103 - DIESEL
	Código	Ø	≠	Kit Bulón	Modelo	Camión 203
	800105	127.0	1.40		Motor	10676cc. 682 N2 MK3 Ø125 - DIESEL (800100)  pág. 53

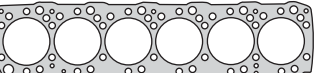
FIAT IVECO

 	Código	Ø	≠	Kit Bulón	Modelo	Camión 619N1 - 697N TB - Bus 391 - 691 - 319N Bus 221A 1970/...
	800007	144.0	1.40	B800000	Motor	13798cc. 8210.02 260HP Ø137 - DIESEL (800000-R)  pág. 51
	800008	139.0	1.25			
800008-CU	139.0	1.25				
	Código	Ø	≠	Kit Bulón	Modelo	Camión Bus 341A - 221 - 221H - 619NP 1965/66 693 N/N1/T/T1 1965/68
	800207	137.0	1.40	B800000	Motor	12883cc. 221 - 8210.01 240HP Ø135 - DIESEL (800200-R)  pág. 54
	Código	Ø	≠	Kit Bulón	Modelo	Camión 150 N Turbo AU130 - Eurocargo 150 E23 - 150 E20 75/80/85/95/100/120/130/150/170 - E15 Turbo - 80/85/100/120 130/135/150/170 E18 Turbo 1991/... - 80/90/100/E21 - 135/150/170/180/E23
	800307	105.3	1.70		Motor	5861cc. 8060.25/45/45S 177/207HP Ø104 - DIESEL (800300-R)  pág. 55 5861cc. 8060.25 143/177HP - 8060.45/S 207/277HP Ø104 - DIESEL (800600-R)  pág. 59
	Código	Ø	≠	Kit Bulón	Modelo	150 Turbo Eurocargo
	800407	105.0	1.70		Motor	3666cc. 8040.04 Ø103 - DIESEL
	Código	Ø	≠	Kit Bulón	Modelo	Euro Trakker - Euro Star - Euro Tech 89/... - 180E42 - 190E31/E42 240E42/E36 - 260E37/E42/E36 - 400E31/E37/E42 - 410E37/E42 440E37/E42 - 720E31 - 380E31 1991/...
	800508	139.0	1.25	B800500	Motor	13798cc. 8210.42L LE2 370HP - 8210.42K KE2 420HP 8210.22.800 310HP Ø137 - DIESEL (800500-R)  pág. 57
	Código	Ø	≠	Kit Bulón	Modelo	Eurocargo 80 E18 - 80 E21 - 90 E18 - 90 E21 Tector - Common Rail Turbo Intercooler EDC 130 E18 - 120 E24 - 120 E28 - 150 E18 2004/...
	800808	105.0	1.20	B800800	Motor	5880cc. 170E22 - F4AE0681D 24V TDI- EDC 180/210HP Ø102 - DIESEL (800800-R)  pág. 61
	Código	Ø	≠	Kit Bulón	Modelo	Cursor 8 Eurotech (E24/31/35), Eurotrakker (E24/27/31/35-T27/31/33/35/36) Stralis (S27/30/31/33/35/36) - Euromover E24 - Cavallino 2007/...
	800908	127.5	1.50	B800900	Motor	8000cc. F2BE0681/F2BE3681 E4 - Turbo Interc. 310HP Ø115 - DIESEL (800900-R)  pág. 62



JUNTA TAPA DE CILINDROS - LINEA PESADA

Head Gaskets - Heavy Duty

FIAT IVECO

801008

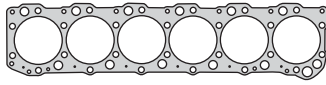

Código	Ø	≠	Kit Bulón
801008	151.0	1.44	

Modelo

Euro Stard Cursor 13 260E48 - 440E46/48 - Stralis 260/440S44
190/260/440/S48/260/440S50/54/56 - Eurotrakker Cursor 13 190/260/340
380E38 - E44-400/410/440/720E38/E44

Motor

13000cc. F3BE3681A Turbo Intercooler 380/420HP Ø135 - DIESEL (801000-R) pág. 64

FORD TRACTOR - CAMION

310407

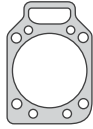

Código	Ø	≠	Kit Bulón
310407	110.0	1.45	B310400 B310500 (HAS17038)

Modelo

F4000 1992/93 - F2000 1980/... - FB4000 1985/... - F1000 1994/96
F14000 - F4000 1994/96 - Cargo - F12000 - F140000 1985/...

Motor

3922cc. D229-4 96HP Ø102 - DIESEL (310400-R) pág. 107
5883cc. D229-6 145/160HP Ø102 - DIESEL (310500-R) pág. 109

320407

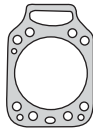

Código	Ø	≠	Kit Bulón
320407	107.0	1.20	

Modelo

Camión F4000 1986/...

Motor

4156cc. D226-4 82HP Ø105 - DIESEL (320400-R) pág. 111

330007

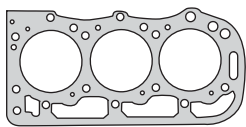

Código	Ø	≠	Kit Bulón
330007	114.5	1.50	

Modelo

Tractor 4600/4110/4140/4190/4200/4400/4410 1965/74
4610/4610H/4610SU 1981/90

Motor

3294cc. BSD 332 - 333/H 81HP Ø111.8 - DIESEL (330000) pág. 65

330107

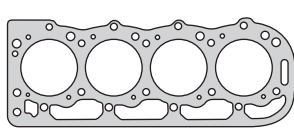

Código	Ø	≠	Kit Bulón
330107	114.5	1.50	

Modelo

5610/5030/5110/5610/5900/6600/6700/7000/7100/7200
6410/6610/6710/7600/7700 - 6810/7410/7610/7710
F2000/4000 - FB4000 - Tractor 6600/6610

Motor

4196cc. BSD 442 - 256 72HP Ø111.8 - **4385cc.** BSD 444 80HP Ø111.8
4392cc. BSD 444T 82HP Ø111.8 - **4393cc.** 268 82/87HP Ø111.8 - DIESEL (330100) pág. 66

330207

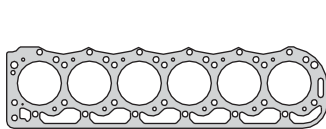

Código	Ø	≠	Kit Bulón
330207	114.5	1.50	

Modelo

7810 - 7910 - 8210 - 8530 1988/... - 8630 - 8750 - 8830 1992/...
Fase I-II - Cargo 6.6/7.8 Simples/Turbo

Motor

6572cc. Fase I-II Cargo 6.6/7.8 Simples/Turbo 110HP Ø111.8 - DIESEL (330200-R) pág. 67

330407

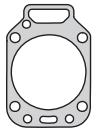

Código	Ø	≠	Kit Bulón
330407	113.4	1.45	

Modelo

Euro I/II/III

Motor

4300cc. 4.10 X10 90HP - 4.10T/TCA 133/167HP Ø103 - DIESEL (330400-R) pág. 113

330407

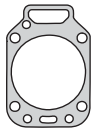

Código	Ø	≠	Kit Bulón
330407	113.4	1.45	

Modelo

F14000 1995/98 - Euro I/II

Motor

6450cc. 6.10 X10 139HP - 6.10T/TCA 201/250HP Ø103 - DIESEL (330700-R) pág. 114

400005 - 400007 - 400008

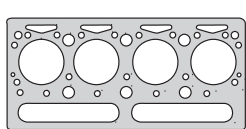

Código	Ø	≠	Kit Bulón
400005	92.5	1.40	B400000 (HAS19038)
400007	92.5	1.40	
400008	92.5	1.15	

Modelo

F100 - Falcon 1970/...

Motor

3336cc. 4.203-P4-192Z 71HP Ø91.49 - DIESEL (400000-R) pág. 121

400107 - 400108

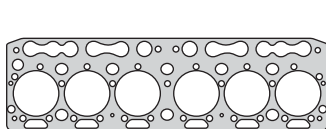

Código	Ø	≠	Kit Bulón
400107	93.0	1.40	
400108	93.0	1.15	

Modelo

F350/600

Motor

5004cc. 6.305 Cadenero 100HP Ø91.44 - DIESEL (400100-R) pág. 122

400207 - 400208

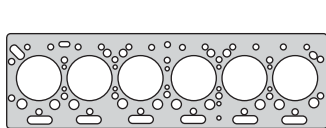

Código	Ø	≠	Kit Bulón
400207	104.0	1.50	B400200 (HAS19038)
400208	104.0	1.30	

Modelo

F600/700

Motor

5798cc. 6.354-2 140HP Ø98.47 - DIESEL (400200-R) pág. 123

JUNTA TAPA DE CILINDROS - LINEA PESADA

Head Gaskets - Heavy Duty



FORD TRACTOR - CAMION

400307 - 400308

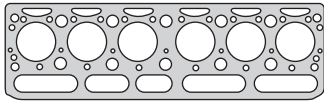

Código	Ø	≠	Kit Bulón
400307	92.5	1.40	B400300
400308	92.5	1.25	(HAS19038)

Modelo F100 - F350 - F600 1974/...

Motor **5004cc.** 6PF- 305 102HP Ø91.44 - DIESEL (400300-R) pág. 124
5004cc. 6PF- 305 Poten. 100HP Ø91.49 - DIESEL (410100-R) pág. 137

400407 - 400408

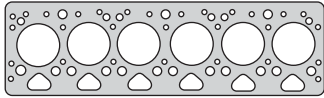

Código	Ø	≠	Kit Bulón
400407	104.0	1.50	B400200
400408	104.0	1.45	(HAS19038)

Modelo F7000 Camiones - Pesados y Semipesados

Motor **5798cc.** 6.354-4 Turbo 172HP Ø98.42 - DIESEL (400400-R) pág. 125

400907

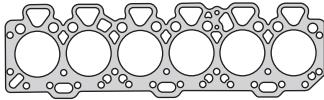

Código	Ø	≠	Kit Bulón
400907	104.0	1.45	B400200
			(HAS19038)

Modelo F600/700

Motor **5798cc.** 6.354-1 135HP Ø98.43 - DIESEL (400900-R) pág. 128

410907

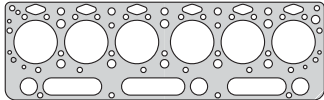

Código	Ø	≠	Kit Bulón
410907	107.0	1.50	

Modelo F600/750/1100 - F6000 - F7500/11000

Motor **5840cc.** 6-357 Agrícola 91HP - Industrial 108HP Ø104.14 - DIESEL (410900-R) pág. 145

420007

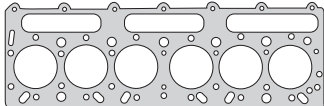

Código	Ø	≠	Kit Bulón
420007	109.0	1.50	

Modelo F400/600/7000/11000/12000/13000

Motor **5840cc.** 6-358 Agrícola 118HP - Industrial 127HP Ø104.14 - DIESEL (420000-R) pág. 146

870007

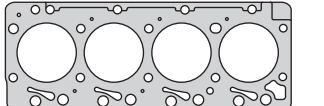

Código	Ø	≠	Kit Bulón
870007	106.0	1.60	B870000

Modelo F4000 2000/... - Cargo 915 - Euro II

Motor **3900cc.** 4B 100HP - 4BT/BTA 130HP Ø102 - DIESEL (870000-R) pág. 15

870107

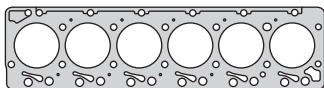

Código	Ø	≠	Kit Bulón
870107	106.0	1.60	B870100

Modelo F14000 - Turbo - F4000 1999/... - 1416 Euro 1989/93

Motor **5900cc.** 6B 180HP - 6BT/BTA 205HP Ø102 - DIESEL (870100-R) pág. 17

870207

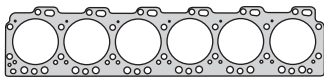

Código	Ø	≠	Kit Bulón
870207	120.0	1.50	B870200

Modelo Cargo 1722/1730/2625 1998/... - F14000 1999/...

Motor **8300cc.** 6C 254HP - 6CT/CTA 294HP Ø114 - DIESEL (870200-R) pág. 19

870307

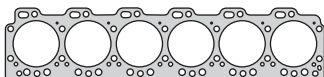

Código	Ø	≠	Kit Bulón
870307	120.0	1.50	B870200

Modelo Cargo 1722 - 1730 - 2625 1998/... - F14000

Motor **8300cc.** 6C 254HP - 6CT/CTA 294HP Ø114 - DIESEL

870608

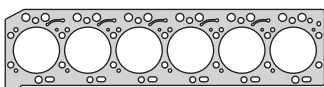

Código	Ø	≠	Kit Bulón
870608	123.5	1.80	B870200

Modelo Ford 2632E/2932E/4432E/4532E/5032E

Motor **8270cc.** ISCe 6 24V Serie C 1832/2632 315HP Ø114 - DIESEL (870600-R) pág. 22

HANOMAG

750009

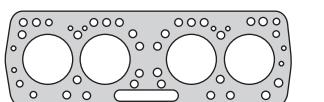

Código	Ø	≠	Kit Bulón
750009-0.80	117.5	0.80	
750009-0.60	117.5	0.60	

Modelo Tractor - D57 1963/...

Motor **5702cc.** R45/55/60/75 Ø110 - DIESEL (750000) pág. 69



JUNTA TAPA DE CILINDROS - LINEA PESADA

Head Gaskets - Heavy Duty

HANOMAG

750109

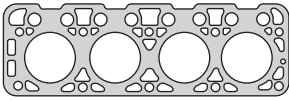

Código	Ø	≠	Kit Bulón	Modelo
750109	96.0	1.00		Tractor - D28LA - D28 1950/55
				Motor 2800cc. R25 - L28 - R35 - R40 - R435 Brillant Ø90 - DIESEL (750100) pág. 70

750209

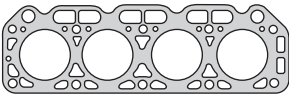

Código	Ø	≠	Kit Bulón	Modelo
750209	96.0	1.00		Brillant - Tractor - D28C 1965/71
				Motor 2800cc. R40 25e - R57 - R46 Ø90 - DIESEL (750200) pág. 71

JOHN DEERE

850007

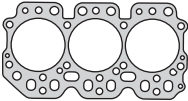

Código	Ø	≠	Kit Bulón	Modelo
850007	119.0	1.40		1030 - 1035 - 1520 - 1530 - 204 - JD302 1973/...
				Motor 2696cc. 3164D Ø102 - DIESEL (850000-R) pág. 73

850107

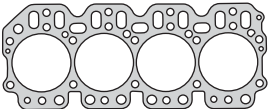

Código	Ø	≠	Kit Bulón	Modelo
850107	119.0	1.40		Tractor Equipos Viales 2120/2030/2035/2270/2280/2340 - JD310/401/440 JD450/480 1974/... - 2130/2135/1640/1840/2140/JD4400 - 540B/550/555 1980/...
				Motor 3590cc. 4219 D 81HP Ø102 - DIESEL (850100-R) pág. 74 3918cc. 4239 D/T 81HP Ø102 - DIESEL (850100-R) pág. 74

850207

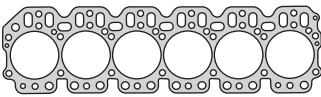

Código	Ø	≠	Kit Bulón	Modelo
850207	119.0	1.40		Tractor Motoniveladora 6329D - 3120/3130/3135/2840/630 JD303/444/540/570/482 - 3140/3040/3640/4040/960/975/2940/3050/3350
				Motor 5395cc. 6.329D 87HP Ø102 - DIESEL (850200-R) pág. 75 5877cc. 6.359D 87HP Ø106.5 - DIESEL (850200-R) pág. 75

850207

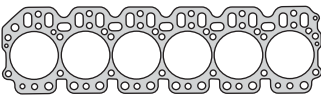

Código	Ø	≠	Kit Bulón	Modelo
850207	119.0	1.40		3350 - 3550 - 6500 - 6600 - 7500 Cosechadora 1075 1991/...
				Motor 5879cc. 6.359D 110/125HP Ø106.5 - DIESEL (850400) pág. 77

850307

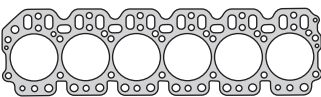

Código	Ø	≠	Kit Bulón	Modelo
850307	115.0	1.40		3420 - J10 - 4420 - 570 - Tractor Motoniveladora 1972/...
				Motor 4976cc. 303 85HP Ø98.04 - DIESEL (850300) pág. 76 5393cc. 329 87HP Ø102 - DIESEL (850300) pág. 76

850507

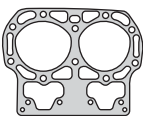

Código	Ø	≠	Kit Bulón	Modelo
850507	156.0	1.60		730 - Tractor 375 1960/74
				Motor 6156cc. Ø155.58 - DIESEL (850500-R) pág. 78

850607

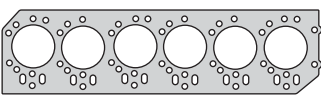

Código	Ø	≠	Kit Bulón	Modelo
850607	120.0	1.40		6505/6605/6615/7500 - Power Tech - MUM - Power Tech Gen Set
				Motor 5395cc. 6068TJ31/J32/J61 - 6068HJ63 150/178HP Ø106 - DIESEL (850601-R) pág. 79

850707

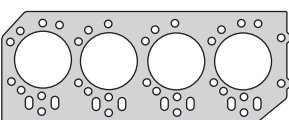



Código	Ø	≠	Kit Bulón	Modelo
850707	120.0	1.40		Motores Agrícolas e Industriales
				Motor 4500cc. 4540TJ31 107HP - 4045DJ31 74HP Ø108 (850701-R) pág. 80

JUNTA TAPA DE CILINDROS - LINEA PESADA



Head Gaskets - Heavy Duty

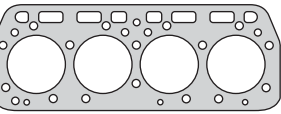



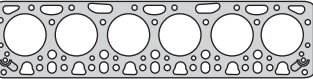

MAHINDRA



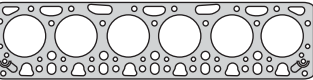

	Código 930007	Ø 90.5	 1.30	Kit Bulón 	Modelo Tractor 255DI - 265DI - Pick Up
	Motor	1300cc. 25HP Ø89.9 - 1800cc. 30HP Ø89.9 2500cc. 55HP Ø89.9 - DIESEL			

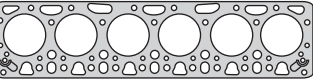

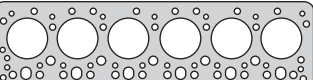

MERCEDES BENZ



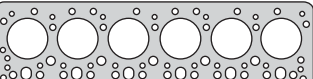

	Código 350005	Ø 93.0	 1.40	Kit Bulón B350000	Modelo MB 3500 - L3250 - L3500 1949/52
	Motor	4580cc. L911 OM311/312 98HP Ø90 - DIESEL (350000-R)  pág. 83			



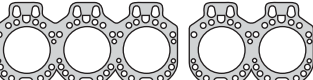

	Código 350205	Ø 96.0	 1.40	Kit Bulón B350300 (HAD19038)	Modelo MB 1112 - 1114 - 0140 - L1112 - L1514 1957/...
	Motor	5100cc. OM 321 108HP Ø95 - DIESEL (350200-R)  pág. 85			



	Código 350305	Ø 98.5	 1.40	Kit Bulón B350300 (HAD19038)	Modelo MB 1114 - 0140 1972/... - OM 352 Turbinado - Aspirado 1981/...
	Motor	5675cc. OM 352 100HP Ø97 - DIESEL (350300-R)  pág. 86			

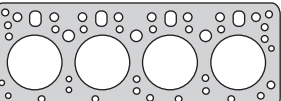

	Código 350405 350407	Ø 98.5 98.5	 1.40 1.30	Kit Bulón B350300 (HAD19038)	Modelo MB 1517 Turbo 0170 - L911 - L1518 1978/... MB OH1215/1315/1316/1319/1320/1420 - Aspirado Turbo 1620/OHL1621 OS1318 - L1915/1314/1318/1365/2018/3611R/2214/2217
	Motor	5675cc. OM 352A 130HP Ø97 - DIESEL (350400-R)  pág. 88 5957cc. OM 366/A/LA 138/170HP Ø97.5 - DIESEL (350900-R)  pág. 93			



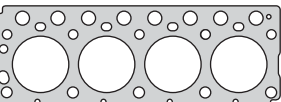

	Código 350405 350407	Ø 98.5 98.5	 1.40 1.30	Kit Bulón B350300 (HAD19038)	Modelo MB 1518 desde 1991/... Motor Híbrido. (Con junta tapa lateral de goma) MB Turbinado Aspirado 1981/...
	Motor	5675cc. OM 352/OM 352A Turbo 130HP Ø97 - DIESEL (352200-R)  pág. 97 5675cc. OM352 - OM352A Ø97 - DIESEL (360200)  pág. 101			

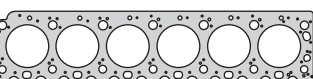
	Código 350607-1 350607-2 350607-3	Ø 130 130 130	 1.30 1.30 1.30	Kit Bulón B350600 (HAS19038)	Modelo MB 1521/1526 1985/87 - 5 cilindros MB 0371 - Bus 1926 1985/... - 6 cilindros
	Motor	9650cc. OM 355-5 84HP Ø128 - DIESEL (350600-R)  pág. 90 11580cc. OM 355-6 230HP Ø128 - DIESEL (360400-R)  pág. 103			

	Código 350805 350807	Ø 99.0 99.0	 1.40 1.40	Kit Bulón B350100 (HAD19038)	Modelo MB 711D - 811D - 609D - 614D - 709D - 809D - OM364 Aspirado 1987/... MB L608 D/Unimog 1966/...
	Motor	3971cc. OM 364 90/115HP Ø97.5 - DIESEL (350800-R)  pág. 92 3786cc. OM 314 85HP Ø97 - DIESEL (350100-R)  pág. 84			

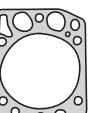
	Código 351007 351008	Ø 104.0 103.5	 1.30 1.20	Kit Bulón B351000 (HAD19038)	Modelo MB Vario 614/814/815/810 - Atego 712/714/715/717/812/814/815/817/917 1017/1214/1215/1217/1317/1517
	Motor	4250cc. OM 904 LA - OM 904 LA IMO Electronico 75/125HP Ø102 - DIESEL (351000-R)  pág. 95			

	Código 352008	Ø 103.5	 1.30	Kit Bulón B352000	Modelo MB Atego I 925/1225/1228/1325/1328/1525/1528/1823/1828/2523 2528/2628 1998/...
	Motor	6370cc. OM906 LA 18V Electrónico - OM906.911/919/920/921/922/923 231/245/279HP Ø102 - DIESEL (352000-R)  pág. 96			

	Código 360008	Ø 143.5	 1.30	Kit Bulón B360000 (HAS17038)	Modelo MB 1630 - 1632 - 1633 - MB485.980 - MB489.960/961-MB475.907/950 MB954/976/979/982/984/986/989/991/994/997/998 - 5 cilindros O372 - O400 - L1395 - 1939 - 1941 1973/... - 6 cilindros
	Motor	9973cc. OM449A/LA - HLA 5 180/200HP Ø128 - DIESEL (360000)  pág. 99 11967cc. OM 447-6 250/300HP Ø128 - DIESEL (360300-R)  pág. 102			



JUNTA TAPA DE CILINDROS - LINEA PESADA

Head Gaskets - Heavy Duty

MERCEDES BENZ

360107

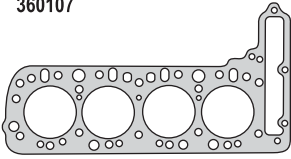

Código	Ø	Δ	Kit Bulón
360107	92.0	1.70	B360100 (HAN12055) (HAN12100)

Modelo

240D/TD 1973/... - 207/307/407/507/510D - L406/407DG - 0309D 1977/...
240GD 1976/87 - MB100/200/300/400/180D/150/170

Motor

2404cc. OM 616.912/934/960 65HP Ø91 - DIESEL (360100-R) pág. 100
OM 616.916/940/961/963 72HP Ø91 - DIESEL (360100-R) pág. 100

360808

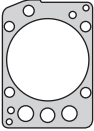

Código	Ø	Δ	Kit Bulón
360808	143.0	0.45	B360800

Modelo

OM457LA/LAIII/HLA/HLA III - OM457.933/938/940/944/949 - OM458.960
970/980/938CAM - O400BUS Camión LS1938 - LK/LS/L2638
Axor 2035/40/44/2540/44/2640/44 - 3340/44 4140/44

Motor

11967cc. OM457 Electrónico - 252 - 456PS 24V 355/380HP Ø128
DIESEL (360800-R) pág. 105

MWM

310407

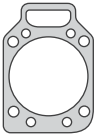

Código	Ø	Δ	Kit Bulón
310407	110.0	1.45	B310400 B310500 (HAS17038)

Modelo

F1000/F4000 1992/96 - F2000 1980/... - FB4000 - Escavadora - Cargo
F14000/F12000 - Tractor S90 - FE105 - FA120 - FE105B - Autoelevador
Camión TX 1600 - Dynapac Cilindro Vibratorio CHF 44 - E300 1983/...

Motor

3922cc. D229-4 96HP Ø102 - DIESEL (310400-R) pág. 107
5883cc. D229-6 145/160HP Ø102 - DIESEL (310500-R) pág. 109
2942cc. D229-3 72HP Ø102 - DIESEL (330800-R) pág. 116

320407

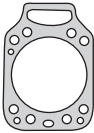

Código	Ø	Δ	Kit Bulón
320407	107.0	1.20	

Modelo

Valmet Tractor 86-ID - Camión F4000 1986/...
MF Tractor 85 1986/...

Motor

4156cc. D226-4 82HP Ø105 - DIESEL (320400-R) pág. 111

320807

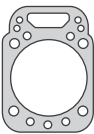

Código	Ø	Δ	Kit Bulón
320807	110.0	1.20	

Modelo

Valmet Tractor 65ID - 62ID 1970/76
Fiat 850E - Valmet Tractor 85ID 1970/76
Dodge Camión 1978/... - Fiat AD7B/980E/S90 - Valmet Tractor 110ID

Motor

2550cc. D225-3 50HP Ø95 - DIESEL (320800-R) pág. 112
2977cc. D225-4 **3400cc.** D225-4 68HP Ø95 - DIESEL (440000) pág. 119
5100cc. D225-6 102HP Ø95 - DIESEL (440100-R) pág. 120

330407

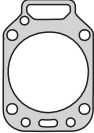

Código	Ø	Δ	Kit Bulón
330407	113.4	1.45	

Modelo

Agrale 7000/7500/8500 - Euro I/II/III - VW 7100/8120/8140/8150/13150
F14000 1995/98 - Euro I/II - VW 13180/15180/16210

Motor

4300cc. 4.10 X10/T/TCA 90/167HP Ø103 - DIESEL (330400-R) pág. 113
6450cc. 6.10 X10/T/TCA 139/250HP Ø103 - DIESEL (330700-R) pág. 114

331208

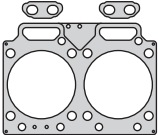

Código	Ø	Δ	Kit Bulón
331208	123.5	1.80	

Modelo

Agrale 8500/9200 - VW Constellation 13.180E/15.180E - (4 cilindros)
VM210/260/310 - VW26.260E/31.260E/17.260EOT/17.210EOD (6 cilindros)

Motor

4800cc. 4.12TCE 150/180HP Ø105 - DIESEL (331200-R MLS) pág. 117
7118cc. 6.12 TCE 210/310HP Ø105 - DIESEL (331300-R MLS) pág. 118

PERKINS - MASSEY FERGUSON

280307

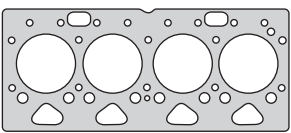

Código	Ø	Δ	Kit Bulón
280307	105.0	1.80	B280300

Modelo

MF290/292/610/620

Motor

4100cc. P4000-4000T 72/86HP Ø100 - DIESEL (401100-R) pág. 130

320407

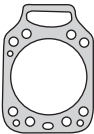

Código	Ø	Δ	Kit Bulón
320407	107.0	1.20	

Modelo

MF Tractor 85 1986/...

Motor

4156cc. D226-4 82HP Ø105 - DIESEL (320400-R) pág. 111

400005 - 400007 - 400008

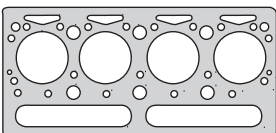

Código	Ø	Δ	Kit Bulón
400005	92.5	1.40	B400000
400007	92.5	1.40	
400008	92.5	1.15	(HAS19038)

Modelo

D100 - D200 1987/... - F100 - Falcón 1970/...
MF Tractor M165 - 265

Motor

3336cc. 4.203-P4-192Z 71HP Ø91.49 - DIESEL (400000-R) pág. 121
3336cc. MF165 - 265 71HP Ø91.49 - DIESEL (400700-R) pág. 81
3336cc. 4.203 Potenciado 71HP Ø91.44 - DIESEL (410000-R) pág. 136

JUNTA TAPA DE CILINDROS - LINEA PESADA

Head Gaskets - Heavy Duty



PERKINS - MASSEY FERGUSON

400005 - 400007 - 400008

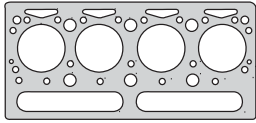

Código	Ø	≠	Kit Bulón
400005	92.5	1.40	B400000
400007	92.5	1.40	(HAS19038)
400008	92.5	1.15	

Modelo MF Potenciado - Tractor 8 BR

Motor **3336cc.** MF265 Potenciado 71HP Ø91.44 - DIESEL (410300-R) pág. 139
3336cc. 4.203 - 8 BR Iny. Ind. 71HP Ø91.49 - DIESEL (420100-R) pág. 147

400107 - 400108

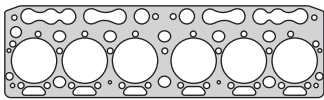

Código	Ø	≠	Kit Bulón
400107	93.0	1.40	
400108	93.0	1.15	

Modelo DP 400/500 1964/... - F350/600

Motor **5004cc.** 6.305 Cadenero 100HP Ø91.44 - DIESEL (400100-R) pág. 122

400207 - 400208

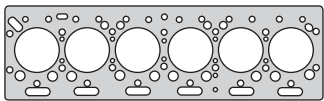

Código	Ø	≠	Kit Bulón
400207	104.0	1.50	B400200
400208	104.0	1.30	(HAS19038)

Modelo DP 600/800 1968/... - F600/700 - MF Tractor 1095 - 1098 - 1195 - 1215
 MF 1095/1098/1215 1970/... - Tractores - Estancieros - Grúas - Rodantes

Motor **5798cc.** 6.354-2 140HP Ø98.47 - DIESEL (400200-R) pág. 123
5798cc. 6.354-2 140HP Ø98.3 - DIESEL (400800-R) pág. 82
5798cc. 6.354-2 Turbo Ø98.47 - DIESEL (401700-R) pág. 134

400307 - 400308

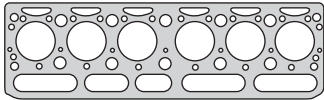

Código	Ø	≠	Kit Bulón
400307	92.5	1.40	B400300
400308	92.5	1.25	(HAS19038)

Modelo F100 - F350 - F600 1974/...
 MF Tractor - PF

Motor **5004cc.** 6PF- 305 102HP Ø91.44 - DIESEL (400300-R) pág. 124
5004cc. 6PF- MF1175 100HP Ø91.44 - DIESEL (400600-R) pág. 127
5004cc. 6PF - 305 Poten. 100HP Ø91.49 - DIESEL (410100-R) pág. 137

400407 - 400408

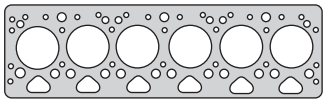

Código	Ø	≠	Kit Bulón
400407	104.0	1.50	B400200
400408	104.0	1.45	(HAS19038)

Modelo D600/800 1976/... - F7000 Camiones - Pes. y Semipesados
 MF Tractor 1215 - 1218

Motor **5798cc.** 6.354-4 Turbo 172HP Ø98.42 - DIESEL (400400-R) pág. 125
5798cc. T6.354-4 172HP Ø98.63 - DIESEL (410400-R) pág. 140

400507 - 400508

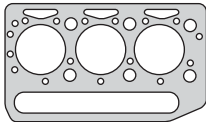

Código	Ø	≠	Kit Bulón
400507	93.0	1.45	B400000
400508	93.0	1.45	(HAS19038)

Modelo Tractor Viñatero
 MF50 Tractor - MF50X/55X - MF135/200/235/250

Motor **2362cc.** P3 - 152 42HP Ø91.44 - DIESEL (400500-R) pág. 126
2502cc. P3 - 152 42HP Ø91.44 - DIESEL (410200-R) pág. 138

400507 - 400508

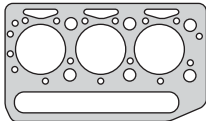

Código	Ø	≠	Kit Bulón
400507	93.0	1.45	B400000
400508	93.0	1.45	(HAS19038)

Modelo MF50/50X/55X/135/200/235/250 - MF 135/515

Motor **2360cc.** 3.152 42HP Ø89 - DIESEL (420400-R) pág. 149
2502cc. 3.152 42HP Ø91.44 - DIESEL (420400-R) pág. 149

400907

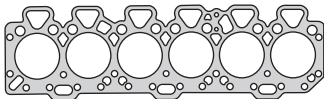

Código	Ø	≠	Kit Bulón
400907	104.0	1.45	B400200 (HAS19038)

Modelo DP 600/800 - F600/700

Motor **5798cc.** 6.354-1 135HP Ø98.43 - DIESEL (400900-R) pág. 128

401507

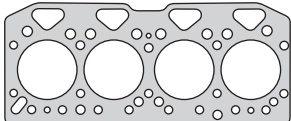

Código	Ø	≠	Kit Bulón
401507	105.0	1.50	B401500

Modelo Phaser 90 - 4.40 - 110T - T4.40 - Phaser 120 Ti - C4.40
 MF6130/6140/6150

Motor **3990cc.** 1004.4/T/TW Ø100 - DIESEL (401500-R) pág. 131

401607

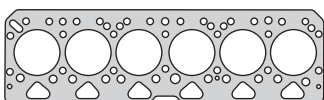

Código	Ø	≠	Kit Bulón
401607	105.0	1.50	

Modelo Phaser 125, MF396/399/630/3085/6160/6170, Phaser 160Ti/180Ti
 MF660/3114/3125/3625/3635/3655/6189/6190/8110/8120/8130

Motor **5985cc.** 1006.6/C/T/TW Ø100 - DIESEL (401600-R) pág. 132

410505 - 410507 - 410508

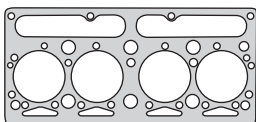

Código	Ø	≠	Kit Bulón
410505	93.0	1.40	
410507	93.0	1.40	
410508	93.0	1.50	

Modelo MF Tractor MF65X, MF40B/65/155/158/165/260/155
 MF164C - CBC1000

Motor **3330cc.** D4.203/AD4.203 Iny. Directa 71HP Ø91.4 - DIESEL (410500-R) pág. 141



JUNTA TAPA DE CILINDROS - LINEA PESADA

Head Gaskets - Heavy Duty

PERKINS - MASSEY FERGUSON

410605 - 410607

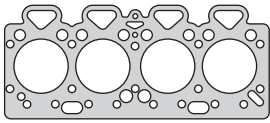

Código	Ø	≠	Kit Bulón	Modelo
410605	104.0	1.70		GM D20 - MF Agrícola - Case 580H - MF85 - MF270/275 MF285/290/220/220A - Hyster H110
410607	104.0	1.70		

Motor **3860cc.** Q20B4 Iny. Directa 70HP Ø98.4 - DIESEL (401000-R) pág. 129
4070cc. A4 - 248 75HP Ø100 - DIESEL (410700-R) pág. 143

410605 - 410607

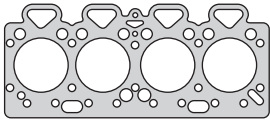

Código	Ø	≠	Kit Bulón	Modelo
410605	104.0	1.70		MF220 - F290 - Tractor MF85X GM D10 - F350 - VW 6.80 - Case 550
410607	104.0	1.70		

Motor **3860cc.** Q20B4.236 Iny. Directa 70HP Ø98.4 - DIESEL (410600-R) pág. 142
4070cc. 4.248 Iny. Directa 70HP Ø101 - DIESEL (410600-R) pág. 142

410605 - 410607

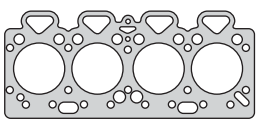

Código	Ø	≠	Kit Bulón	Modelo
410605	104.0	1.70		Case 580H
410607	104.0	1.70		

Motor **3860cc.** 4.236 Iny. Directa 70HP Ø98.4 - DIESEL (420200-R) pág. 148
4070cc. 4.248 Iny. Directa 100HP Ø100 - DIESEL (420200-R) pág. 148

410807 - 410808

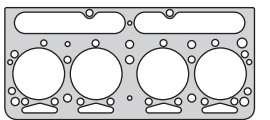

Código	Ø	≠	Kit Bulón	Modelo
410807	93.0	1.40		Pick Up - Camiones livianos
410808	93.0	1.25		

Motor **3330cc.** T 4.33 Turbo 91/95HP Ø91.46 - DIESEL (410800-R) pág. 144

410907

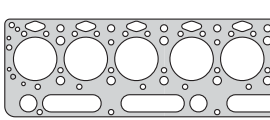

Código	Ø	≠	Kit Bulón	Modelo
410907	107.0	1.50		GM Brasil D60/D70 - Dodge P700D/P900 F600/750/1100 - MF3366 - F6000 - F7500/11000

Motor **5840cc.** 6-357 Agrícola 91HP - Industrial 108HP Ø104.14 - DIESEL (410900-R) pág. 145

420007

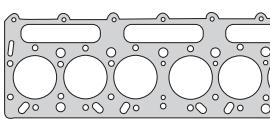

Código	Ø	≠	Kit Bulón	Modelo
420007	109.0	1.50		F400/600/7000/11000/12000/13000 MF 400C

Motor **5840cc.** 6-358 Agrícola 118HP - Industrial 127HP Ø104.14 - DIESEL (420000-R) pág. 146

420205

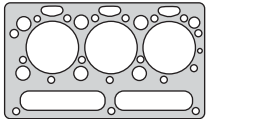

Código	Ø	≠	Kit Bulón	Modelo
420205	93.0	1.40		MF133/135/230/235/240/254/353 - Industrial MF40 - Agrícola

Motor **2500cc.** D3.152-D3.152/2 - G3.152-D3.152/4 Iny. Dir. 100HP Ø91.40
DIESEL (422000-R) pág. 151

420508

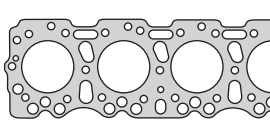

Código	Ø	≠	Kit Bulón	Modelo
420508	112.0	1.20		D170 - P 200/260/270/320 - MF RX 100T

Motor **8850cc.** 510 -540 V8 Ø108 170/183HP

420607

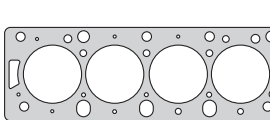

Código	Ø	≠	Kit Bulón	Modelo
420607	86.0	1.50		Rover - Maestro D/TD - Perkins - Marino 4.20 D/TD Leyland Sherpa 185/200/215/220/230/240/255 1986/94 Daf Ka 200/VS 200 1986/...

Motor **1994cc.** Prima 65/80T - Leyland Prima 65 - Daf TN 44 64/80HP Ø84.45
DIESEL (420600-R) pág. 150

423108

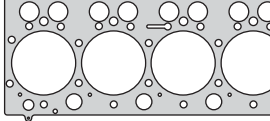

Código	Ø	≠	Kit Bulón	Modelo
423108	121.0	1.30		MF4292, MF4297, Challenger - (4 cilindros)

Motor **4400cc.** 420DS Agco Sisu Power 106/116HP - 110/117HP - 120/129HP
Ø108 - DIESEL (423100-R MLS) pág. 02

423208

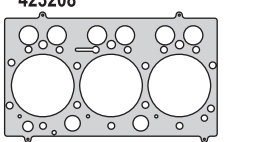

Código	Ø	≠	Kit Bulón	Modelo
423208	121.0	1.30		MF Case-IH CS 68/75 Challenge - (3 cilindros) MF Case-IH CS/CVX120/130/150 - CVX1135/1145/1155/1170/1190 Optima 440F Challenger - MT560B/570B/590B/MF7140 - (6 cilindros)

Motor **3300cc.** 320D/DS 33/69HP Ø108 - DIESEL (423000-R MLS) pág. 01
6600cc. 620D/DS 147/189HP Ø108 - DIESEL (423200-R MLS) pág. 03

JUNTA TAPA DE CILINDROS - LINEA PESADA

Head Gaskets - Heavy Duty



SCANIA

810007 - 810008

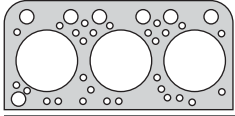

Código	Ø	≠	Kit Bulón
810007	144.0	1.40	
810008	144.0	1.80	

Modelo

Camión - Omnibús L75/76/L/LB/LBS110 - L/LB/LS/LT/LBS/LBT111

Motor

11020cc. D11 - DS11 280/333HP Ø127 - DIESEL (810000-R) pág. 153

810108

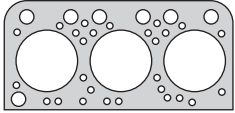

Código	Ø	≠	Kit Bulón
810108	147.0	1.25	

Modelo

LB/LBS110 - L/LS/LT/LBS/LBT111- G/L/R/T112 - P/R113 - P113HK R113HK - T113 - K113CBL - K113GLP - K113TLB - K113TLP 1975/...

Motor

11020cc. D11/DS11/DSC11/DN11/DTC11 272/354HP Ø127 - DIESEL (810100-R) pág. 154

810208

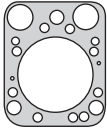

Código	Ø	≠	Kit Bulón
810208	147.0	0.60	

Modelo

R142 - T142 - R143 - T143 - R144 - T144

Motor

14190cc. D14 - DS14 - DSC14 400/460/500/530HP Ø127 - DIESEL

810407 - 810408

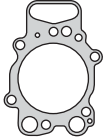

Código	Ø	≠	Kit Bulón
810407	133.0	1.70	
810408	133.0	1.00	

Modelo

P124 - R124 - T124 1996/2001

Motor

11700cc. DSC12.01/02 360/420HP Ø127 - DIESEL

SHANGAI

910905

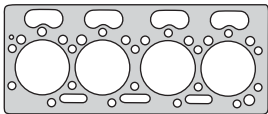

Código	Ø	≠	Kit Bulón
910905	101.0	1.40	

Modelo

Tractor

Motor

495A Tracción Simple - 485A18 Tracción Doble - DIESEL (910900) pág. 157

VALMET

310407

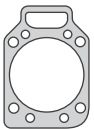

Código	Ø	≠	Kit Bulón
310407	110.0	1.45	B330800 (HAS17038)

Modelo

Autoelevador - E300 - Tractor 68 1983/...

Motor

2942cc. D229-3 72HP Ø102 - DIESEL (330800-R) pág. 116

320407

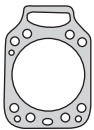

Código	Ø	≠	Kit Bulón
320407	107.0	1.20	

Modelo

Tractor 86-ID

Motor

4156cc. D226-4 82HP Ø105 - DIESEL (320400-R) pág. 111

320807

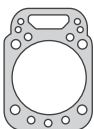

Código	Ø	≠	Kit Bulón
320807	110.0	1.20	

Modelo

Tractor 65ID - 62ID 1970/76 - Tractor 85ID 1970/76 - Tractor 110ID

Motor

2550cc. D225-3 50HP Ø95 - DIESEL (320800-R) pág. 112
2977cc. D225-4 **3400cc.** D225-4 68HP Ø95 - DIESEL (440000) pág. 119
5100cc. D225-6 102HP Ø95 - DIESEL (440100-R) pág. 120

VALTRA

423108

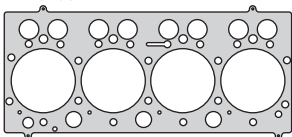

Código	Ø	≠	Kit Bulón
423108	121.0	1.30	

Modelo

Valtra A950/A990 (4x2, 4x4), BM100/BM110 (4x2, 4x4) - (4 cilindros)

Motor

4400cc. 420D/DS Agco Sisu Power 106/116HPØ108 - DIESEL (423100-R MLS) pág. 02

423208

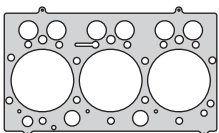

Código	Ø	≠	Kit Bulón
423208	121.0	1.30	

Modelo

Valtra A65/A75/305/355/365/405/455/465/555/565/600/700 - (3 cilindros)
 Valtra 8000 - (6 cilindros)

Motor











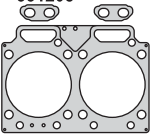

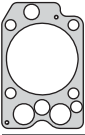
3300cc. 320D/DS 33/69HP Ø108 - DIESEL (423000-R MLS) pág. 01
6600cc. 620D/DS 147/189HP Ø108 - DIESEL (423200-R MLS) pág. 03

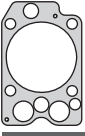

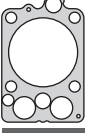

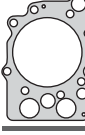
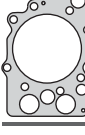



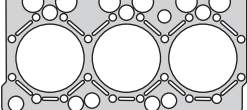

JUNTA TAPA DE CILINDROS - LINEA PESADA

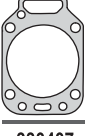
Head Gaskets - Heavy Duty

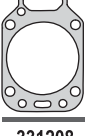
VOLVO

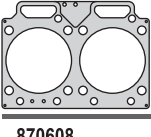
	Código	Ø	⊗	Kit Bulón	Modelo	VM210/260/310 - (6 cilindros)
	331208	113.5	1.30		Motor	7118cc. 6.12 TCE 210/260/310HP Common Rail Ø105 - DIESEL (331300-R MLS)  pág. 118
	Código	Ø	⊗	Kit Bulón	Modelo	B58 - B10M 1987/... - N10 1985/89 - (6 cilindros)
	880008	136.5	1.40		Motor	9600cc. THD 101 KC 273/310HP Ø120.6 - DIESEL (880000-R)  pág. 159 9600cc. TD 100G/101G/101F Ø120.6 - DIESEL (880300-R)  pág. 165
	Código	Ø	⊗	Kit Bulón	Modelo	NL10 1998/... - NL10 1989/97 - (6 cilindros)
	880008	136.5	1.40		Motor	9600cc. EDC Ø120.6 - DIESEL (880500-R)  pág. 169 9600cc. TD 102F/102FS 234/317HP Ø120.6 - DIESEL (880600-R)  pág. 171
	Código	Ø	⊗	Kit Bulón	Modelo	B58 1980/85 - N10 1980/85 - (6 cilindros)
	880108	130.0	1.40		Motor	9600cc. THD 100D 230/260HP Ø120.6 - DIESEL (880100-R)  pág. 161 9600cc. TD 100A 230/260HP Ø120.6 - DIESEL (880200-R)  pág. 163
	Código	Ø	⊗	Kit Bulón	Modelo	N12 1980/89 - (6 cilindros)
	880208	146.0	1.40		Motor	11950cc. TD 121G/120GA 295/360HP - 121F 328/385HP Ø130.2 - DIESEL
	Código	Ø	⊗	Kit Bulón	Modelo	NL12 1980/89 - NL12 1997/... - NL12 1989/96 - (6 cilindros)
	880308	147.5	1.40	B880400  (HAS21038)	Motor	11950cc. TD 121G/120GA/121F Ø130.2 - DIESEL (880400-R)  pág. 165 11950cc. EDC Ø120.6 - DIESEL (880700-R)  pág. 173 11950cc. TD 122FS 396HP Ø130.2 - DIESEL (880800-R)  pág. 175
	Código	Ø	⊗	Kit Bulón	Modelo	B7- FL7 1985/... - FL7, FS7 1991/... - B7R 1998/...
	880908	119.0	1.40		Motor	6725cc. TD71F/FA/FAQ/FC/FCQ/FD/FQ/FS/FSQ/G/E/FSO 230/245HP TD73E/ES 230/260HP D7A/B 260/285HP D7C 275HP Ø104.8

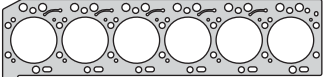
VOLKSWAGEN

	Código	Ø	⊗	Kit Bulón	Modelo	VW 7100/8120/8140/8150
	330407	113.4	1.45		Motor	4300cc. 4.10 X10 90HP - 4.10T/TCA 133/167HP Ø103 - DIESEL (330400-R)  pág. 113
	Código	Ø	⊗	Kit Bulón	Modelo	VW 13180/15180/16210
	330407	113.4	1.45		Motor	6450cc. 6.10 X10 139HP - 6.10T/TCA 201/250HP Ø103 - DIESEL (330700-R)  pág. 114
	Código	Ø	⊗	Kit Bulón	Modelo	VW Constellation 13.180E- 15.180E - (4 cilindros) VW 26.260E, 31.260E, 17.260EOT, 17.210EOD - (6 cilindros)
	331208	113.5	1.30		Motor	4800cc. 4.12TCE 150/180HP Ø105 - DIESEL (331200-R MLS)  pág. 117 7118cc. 6.12 TCE 210/260/310HP Ø105 - DIESEL (331300-R MLS)  pág. 118
	Código	Ø	⊗	Kit Bulón	Modelo	VW 17220/17300/17310/18310/19320/26320
	870608	123.5	1.80	B870200	Motor	8270cc. ISCe 6 24V Serie C 1832/2632 315HP Ø114 - DIESEL (870600-R)  Pág 22



MOTORES GASOLINA - GASOLINE ENGINES

960559 WINCO JUNTA TAPA DE CILINDROS

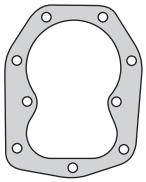

Motor	LK
Ø de Boca	84
OE	2001-19

960560 WINCO JUNTA TAPA DE CILINDROS

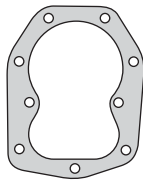

Motor	
Ø de Boca	84
OE	1001-26

960564 LOMBARDINI JUNTA TAPA DE CILIN.

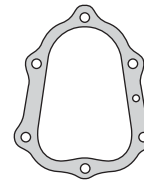

Motor	LA65
Ø de Boca	72
OE	

960565 LOMBARDINI JUNTA TAPA DE CILIN.

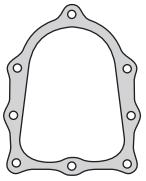

Motor	LA 80 7.5HP
Ø de Boca	85
OE	

960566 LOMBARDINI JUNTA TAPA DE CILIN.

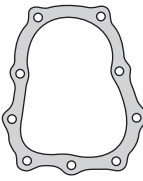

Motor	LA 85 9HP
Ø de Boca	84
OE	

960567 LOMBARDINI JUNTA TAPA DE CILIN.



Motor	LA60
Ø de Boca	95
OE	

960568 ORIPON JUNTA TAPA DE CILINDROS

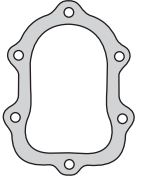

Motor	14HP
Ø de Boca	96
OE	

960569 VILLA JUNTA TAPA DE CILINDROS

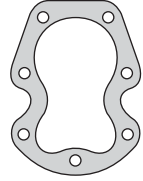

Motor	124/1-130T 25HP
Ø de Boca	60
OE	

960570 VILLA JUNTA TAPA DE CILIN.

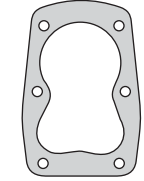

Motor	240V 3HP - 4.5HP
Ø de Boca	70
OE	

960571 VILLA JUNTA TAPA DE CILINDROS

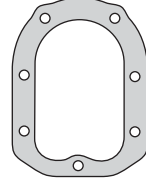

Motor	8HP 401/1 16HP
Ø de Boca	85
OE	

960574 WUAKESHA JUNTA TAPA DE CILIN.

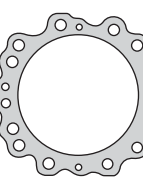

Motor	
Ø de Boca	258.5
OE	

Motor	
Ø de Boca	
OE	

MOTORES DIESEL - DIESEL ENGINES

960552 DIAR JUNTA TAPA DE CILINDROS

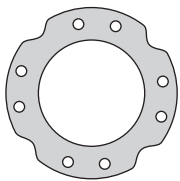

122 x 180 mm.	
Motor	23A
Ø de Boca	122
OE	

960553 DIAR JUNTA TAPA DE CILINDROS

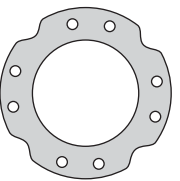

115 x 185 mm.	
Motor	23A
Ø de Boca	115
OE	

960554 DIAR JUNTA TAPA DE CILINDROS

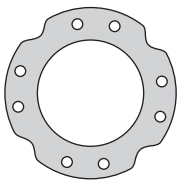

129 x 185 mm.	
Motor	23A
Ø de Boca	129
OE	

960555 DIAR JUNTA TAPA DE CILINDROS

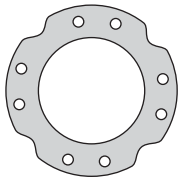

122 x 185 mm.	
Motor	23A
Ø de Boca	122
OE	

960556 DIAR JUNTA TAPA DE CILINDROS

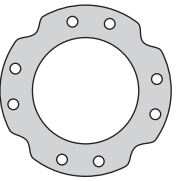

115 x 180 mm.	
Motor	23A
Ø de Boca	115
OE	

960557 DIAR JUNTA TAPA DE CILINDROS

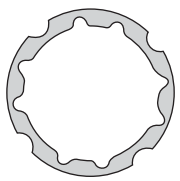

180 mm.	
Motor	23A
Ø de Boca	180
OE	

960558 DIAR JUNTA TAPA DE CILINDROS

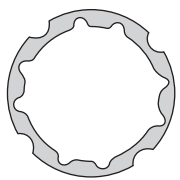

185 mm.	
Motor	
Ø de Boca	185
OE	

960572 LISTER JUNTA TAPA DE CILINDROS

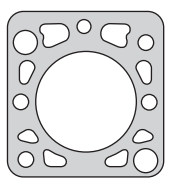

Motor	5HP - 6HP
Ø de Boca	118
OE	

Motor	
Ø de Boca	
OE	



taranto



HAB12075

BARRA DE EXTENSION CON LUZ LED

Práctica barra de extensión con encastre de 1/2 x 75mm. Para trabajar en lugares oscuros. Superbrillante y potente luz led con baterías alojadas en el interior de la barra.



KIT HAK12-38 Taranto.

Práctico Juego de llaves especiales para motor.

- ▶ Contiene todos los tipos y medidas de herramientas necesarios para el trabajo sobre vehículos de última generación.
- ▶ Posee tubos y tubos con punta de alta resistencia son fabricados en acero cromo vanadio con doble cromado y moleteados para mejorar el agarre.
- ▶ Encastre de 12.7 mm. Con espacio para bola de retención.



HERRAMIENTAS ESPECIALES PARA MOTOR

Set of Special Automotive Tools



KIT HAK12-38



FORMACION DEL CODIGO DE ARTICULO

H	A	T	5	5	0	5	5
LINEA		TIPO	MEDIDA		LARGO HERRAMIENTA		

LINEA	TIPOS DE LLAVE
HA: Herramienta de ajuste	D: Tubo Estriado S: Tubo Hexagonal B: Barra de Extención E: Tubo Torx Hembra N: Tubo con Punta Estriado R: Tubo con Punta Ribe T: Tubo con Punta Torx

KIT HAK 12-38

38 PIEZAS ENCASTRE DE 12.7mm (1 2")

CANT.	CONTENIDO
9	TUBOS HEXAGONALES 12,13,14,15,17,19,21,24,27mm
5	TUBOS ESTRIADOS 10,12,14,17,19mm
6	TUBOS TORX HEMBRA E10,E12,E14,E16,E18,E20
5	TUBOS CON PUNTA TORX T55X55,T55X100,T60X55,T60X100,T70X100mm
5	TUBOS CON PUNTA ESTRIADA M9X100,M10X55,M10X100,M12X55,M12X100mm
3	TUBOS CON PUNTA RIBE R10X168,R12X63,R14X63mm.
5	TUBOS CON PUNTA HEXAGONAL H8X55,H8X90,H8X120,H10X55,H10X140mm.

TUBOS HEXAGONALES	CODIGO	DESCRIPCION	D (mm)	L (mm)
	HAS12038	HEXAGONAL 12mm	22	38
	HAS13038	HEXAGONAL 13mm	22	38
	HAS14038	HEXAGONAL 14mm	22	38
	HAS15038	HEXAGONAL 15mm	22	38
	HAS17038	HEXAGONAL 17mm	24	38
	HAS19038	HEXAGONAL 19mm	26	38
	HAS21038	HEXAGONAL 21mm	28	38
	HAS24038	HEXAGONAL 24mm	32	38
	HAS27038	HEXAGONAL 27mm	36	42

TUBOS ESTRIADOS	CODIGO	DESCRIPCION	D (mm)	L (mm)
	HAD10038	ESTRIADO 10mm	22	38
	HAD12038	ESTRIADO 12mm	22	38
	HAD14038	ESTRIADO 14mm	22	38
	HAD17038	ESTRIADO 17mm	24	38
	HAD19038	ESTRIADO 19mm	26	38

TUBOS TORX	CODIGO	DESCRIPCION	D (mm)	L (mm)
	HAE10038	TORX Hembra E10	23	38
	HAE12038	TORX Hembra E12	23	38
	HAE14038	TORX Hembra E14	23	38
	HAE16038	TORX Hembra E16	23	38
	HAE18038	TORX Hembra E18	23	38
	HAE20038	TORX Hembra E20	24	38

TUBOS CON PUNTA TORX	CODIGO	DESCRIPCION	D (mm)	L (mm)
	HAT55055	Punta TORX T55 x 55mm	24	55
	HAT55100	Punta TORX T55 x 100mm	24	100
	HAT60055	Punta TORX T60 x 55mm	24	55
	HAT60100	Punta TORX T60 x 100mm	24	100
	HAT70100	Punta TORX T70 x 100mm	24	100

TUBOS CON PUNTA ESTRIADA	CODIGO	DESCRIPCION	D (mm)	L (mm)
	HAN09100	Punta ESTRIADA M9 x 100mm	24	100
	HAN10055	Punta ESTRIADA M10 x 55mm	24	55
	HAN10100	Punta ESTRIADA M10 x 100mm	24	100
	HAN12055	Punta ESTRIADA M9 x 100mm	24	55
	HAN12100	Punta ESTRIADA M12 x 55mm	24	100

TUBOS CON PUNTA RIBE	CODIGO	DESCRIPCION	D (mm)	L (mm)
	HAR10168	Punta RIBE R10 x 168mm	24	168
	HAR12063	Punta RIBE R12 x 63mm	24	63
	HAR14063	Punta RIBE R14 x 63mm	24	63

TUBOS CON PUNTA HEXAGONAL	CODIGO	DESCRIPCION	D (mm)	L (mm)
	HAH08055	Punta HEXAGONAL H8 x 55mm	24	55
	HAH08090	Punta HEXAGONAL H8 x 90mm	24	90
	HAH08120	Punta HEXAGONAL H8 x 120mm	24	120
	HAH10055	Punta HEXAGONAL H10 x 55mm	24	55
	HAH10140	Punta HEXAGONAL H10 x 140mm	24	140

BARRA DE EXTENSION CON LUZ LED ENCASTRE 12.7mm (1 2")

TUBOS CON PUNTA RIBE	CODIGO	DESCRIPCION	D (mm)	L (mm)
	HAB12075	Barra de extensión 1/2" x 75 mm con luz led	12.7	75

Práctica barra de extensión con encastre de 1 2"/x 75mm. Para trabajar en lugares oscuros!

Super brillante y potente luz LED con baterías alojadas en el interior de la barra.

3 baterías de repuesto incluidas en el kit.

AGCO/SISU



Motor/Engine	Cm³	HP	Ø
320D/DS Agco Sisu Power	3300	33/69	108

M. Ferguson: Case-IH CS 68/75 - Challenger
Valtra: A65/A75/305/355/365/405/455
 465/555/565/600/700



DIESEL

Nº OE	Descripción/Description	Mat.	Ref.
	Jgo. de juntas para motor		● 423000-R MLS
	Junta tapa cilindros Ø 121 ± 1.30	MLS 1	423208
	Junta tapa válvulas	NB 1	423210
	Junta para cárter	NB 1	423011
	Tapa distribución	NB 1	423112
	Placa distribución	NB 1	423113
	Bomba de agua	NB 1	423214
	Múltiple admisión	NH 1	423217
	Salida de escape	FCH 1	423218
	Junta bomba combustible	NB 1	423228
	Bomba de agua a block	NB 1	423231
	Junta	NB 1	423234
	Junta	NB 1	423235
	Junta	NB 1	423242
	Junta	NB 1	423143
	Junta	NB 1	423144
	Junta	NB 1	423244
	Junta	NB 1	423145
	Junta	NB 1	423245
	Junta base bomba inyectora	NB 1	423146
	Junta	NB 1	423246
	Junta	NB 1	423247
	Junta	NB 1	423248
	Junta	CG 1	423148
	Junta	NB 1	423149
	Junta	NB 1	423262
	Junta	NB 1	423263
	Arandela A 21.8 x 18.3 x 1.5 C	CU 5	
	Arandela A 28.8 x 24.5 x 2 C	CU 1	
	Arandela A 10 x 20 x 3 C	CU 3	
	Arandela A 10.3 x 13.3 x 1 C	CU 4	
	Arandela A 13.3 x 16.7 x 1 C	CU 1	
	Arandela A 14.3 x 17.8 x 1.5 C	CU 1	
	O´ring G 48 x 5	GS 1	
	O´ring G 29 x 5	GS 1	
	O´ring G 10 x 21 x 8	GS 2	
	O´ring G 19.7 x 27.7 x 6.8	GS 3	
614500002	Retén bancada 110 x 140 x 12	VF 1	R423111VF
836673387	Retén distribución 58 x 80 x 12	V 1	R423112V

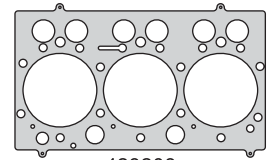

423208



423210

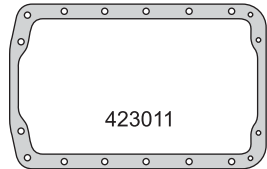

423011

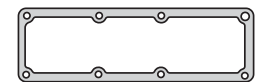

423112

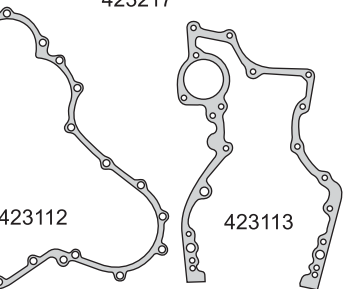

423113



423214

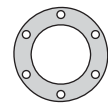

423218



423228

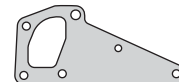

423231



423234



423143

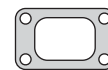

423242

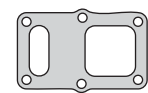

423235



423244



423245



423144



423145



423246



423247



423248



423146



423149



423262



423148



423263



R423111VF



R423112V

AGCO/SISU



Motor/Engine	Cm³	HP	Ø
420D/DS Agco Sisu Power	4400	106/129	108

M. Ferguson: MF4292, MF4297 - Challenger
Valtra: A950/A990 (4x2, 4x4)
 BM100/BM110 (4x2, 4x4)



DIESEL

Nº OE	Descripción/Description	Mat.	Ref.
	Jgo. de juntas para motor		● 423100-R MLS
	Junta tapa cilindros Ø 121 ± 1.30	MLS	1 423108
	Junta tapa válvulas	NB	1 423110
	Junta para cárter	NB	1 423111
	Tapa distribución	NB	1 423112
	Placa distribución	NB	1 423113
	Múltiple admisión	NH	1 423117
	Bomba de agua	NB	1 423114
	Salida de escape	FCH	1 423118
	Bomba de agua a block	NB	1 423131
	Junta	NB	1 423143
	Junta	NB	1 423149
	Base bomba inyectora	NB	1 423146
	Junta	NB	3 423144
	Junta	NB	1 423145
	Junta	CG	1 423148
	Junta	NB	1 423165
836647502	Sello camisa cilindros G 113.89 x 3.53	GS	6
	Anillo G 20 x 27.5 x 7	GS	4
	Anillo G 9.5 x 21.2 x 8	GS	1
	O´ring G 15.5 x 2.3	GS	1
	O´ring G 24.5 x 5	GS	1
	O´ring G 35 x 4	GS	1
	O´ring G 110.72 x 3.53	GS	4
	Arandela A 18.5 x 21.5 x 1.5 C	CU	8
	Arandela A 10 x 20 x 3 C	CU	4
	Arandela A 14.3 x 17.5 x 1.5 C	CU	1
	Arandela A 10.3 x 13.3 x 1 C	CU	7
	Arandela A 12.3 x 15.3 x 1.5 C	CU	2
	Arandela A 7 x 11 x 1.5 C	CU	1
	Arandela A 8.5 x 11 x 1 C	CU	1
	Arandela A 6.5 x 9.5 x 1 C	CU	10
614500002	Retén bancada 110 x 140 x 12	VF	1 R423111VF
836673387	Retén distribución 58 x 80 x 12	V	1 R423112V

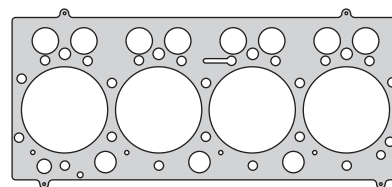

423108



423110

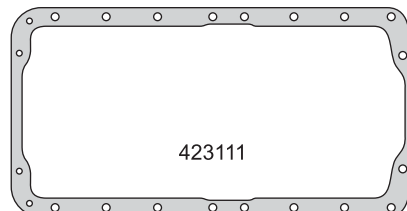

423111

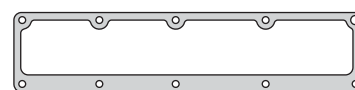

423117

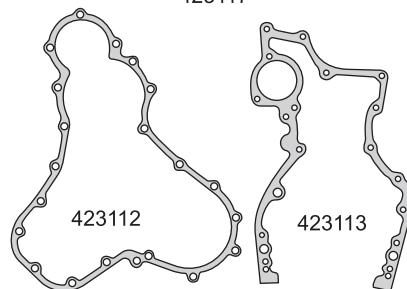

423112

423113

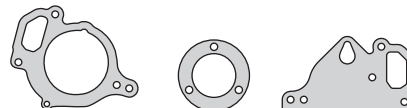

423114

423118

423131

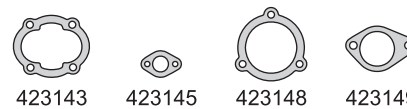

423143

423145

423148

423149



423146

423144

423165

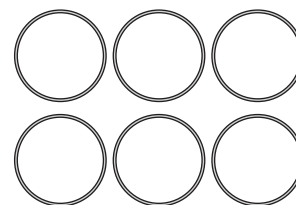

G 113.89 x 3.53



G 110.72 x 3.53



R423111VF



R423112V

AGCO/SISU



Motor/Engine	Cm³	HP	Ø
620D/DS Agco Sisu Power	6600	147/189	108

M. Ferguson: Case-IH CS/CVX120/130/150
CVX1135/1145/1155/1170/1190
Optima 440F Challenger
MT560B/570B/590B/MF7140
8000

Valtra:



DIESEL

Nº OE	Descripción/Description	Mat.	Ref.
	Jgo. de juntas para motor		● 423200-R MLS
	Junta tapa cilindros Ø 121 ± 1.30	MLS	2 423208
	Junta tapa válvulas	NB	2 423210
	Junta para cárter	NB	1 423211
	Tapa distribución	NB	1 423112
	Placa distribución	NB	1 423113
	Bomba de agua	NB	1 423214
	Múltiple admisión	NH	2 423217
	Salida de escape	FCH	1 423218
	Junta bomba combustible	NB	1 423228
	Bomba de agua a block	NB	1 423231
	Junta	NB	1 423234
	Junta	NB	1 423235
	Junta	NB	1 423242
	Junta	NB	1 423143
	Junta	NB	1 423144
	Junta	NB	1 423244
	Junta	NB	1 423145
	Junta	NB	1 423245
	Junta base bomba inyectora	NB	1 423146
	Junta	NB	1 423246
	Junta	NB	1 423247
	Junta	NB	2 423248
	Junta	CG	1 423148
	Junta	NB	1 423149
	Junta	NB	1 423262
	Junta	NB	1 423263
	Arandela A 21.8 x 18.3 x 1.5 C	CU	10
	Arandela A 28.8 x 24.5 x 2 C	CU	1
	Arandela A 10 x 20 x 3 C	CU	6
	Arandela A 10.3 x 13.3 x 1 C	CU	7
	Arandela A 13.3 x 16.7 x 1 C	CU	3
	Arandela A 14.3 x 17.8 x 1.5 C	CU	1
	O´ring G 48 x 5	GS	1
	O´ring G 29 x 5	GS	1
	O´ring G 10 x 21 x 8	GS	4
	O´ring G 19.7 x 27.7 x 6.8	GS	6
614500002	Retén bancada 110 x 140 x 12	VF	1 R423111VF
836673387	Retén distribución 58 x 80 x 12	V	1 R423112V

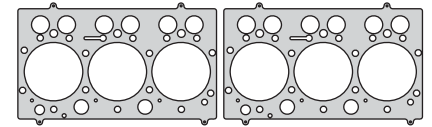

423208

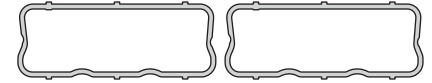

423210

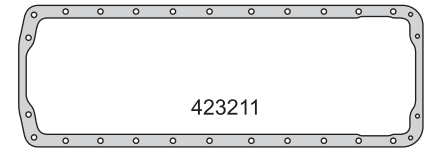

423211

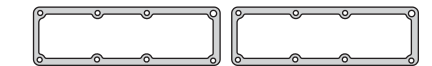

423214

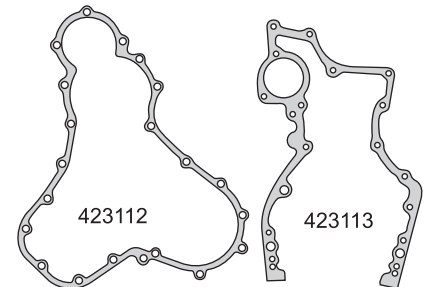

423112

423113

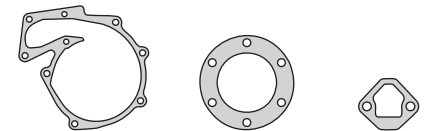

423214

423218

423228

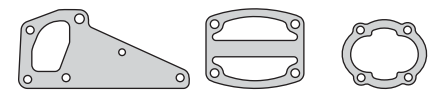

423231

423234

423143

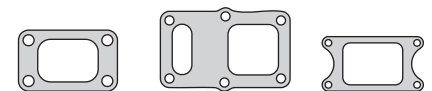

423242

423235

423244

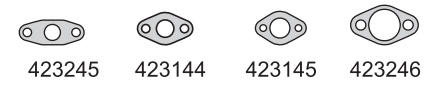

423245

423144

423145

423246

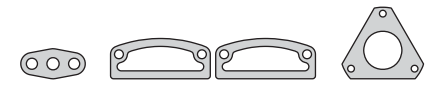

423247

423248

423146



423149

423262

423148



423263



R423111VF

R423112V



taranto



Paso a Paso



Lubricar las roscas y debajo de la cabeza del tornillo



Seguir la especificación Taranto incluida en cada caja de tornillos, generalmente el ajuste inicial se da con torquimeto.



Realizar el apriete final según lo especificado en la ficha de ajuste. Para la generalidad de los motores modernos el apriete es angular.

RECUERDE... Siempre que se realiza un cambio de Junta y se aprieta la Tapa de Cilindros con un ajuste angular, se deben cambiar los tornillos de fijación, para asegurar así un correcto funcionamiento de la pieza.

Tornillos de Tapa de Cilindros Taranto.

Las consecuencias de NO cambiar los Tornillos de Tapa de Cilindros son más costosas que reemplazarlos. No lo dude!!!

- ▶ Indispensable para el buen funcionamiento del motor.
- ▶ Diseñados para resistir el estiramiento.
- ▶ Resisten altas temperaturas y presiones, característica de los motores modernos de alta performance.



BEDFORD**taranto**

Motor/Engine	Cm³	HP	Ø
300D	4927	97	98.3

Chevrolet: J6 1961/71

DIESEL



Nº OE	Descripción/Description	Mat.	Ref.
	Jgo. de juntas para motor		● 210000-R
6397318	Junta tapa cilindros Ø 101 \pm 1.85	FCH	1 210005
7137894	Junta tapa válvulas superior	CG	1 210010
7075064	Junta para cárter	CG	1 210011
6322449	Tapa distribución	CG	1 210012
6322652	Placa distribución	NB	1 210013
7126032	Bomba de agua	NB	1 210014
9309	Jgo. múltiple escape (4)	NFT	1 210016
7135808	Múltiple admisión	NB	1 210017
7115805	Salida de escape	FCH	1 210018
7126030	Bomba de agua a block	NB	1 210019
7143019	Bomba aceite a block	NB	1 210027
6303254	Tapa termostato	NB	1 210032
7075136	Codo agua	CB	1 210033
1530250	Tapa filtro aceite	CG	1 210035
7133433	Tapa válvula lateral	CG	1 210036
6337135	Tapa trasera bomba vacío	NB	1 210037
6353757	Placa bomba vacío	NB	1 210038
6353753	Extremo mando bomba vacío	NB	1 210039
7140434	Placa tapa superior bomba	NB	1 210040
7140429	Cuerpo válvula entrada	NB	1 210041
6322449	Tapa distribución	CGT	210045
	Comando bomba combustible	NB	1 400146
	Jgo. juntas depresor (5)	VS	1 210047
7137885	Buje placa distribución	GS	2 210048
	Jgo. juntas caja velocidades FAE 5ta.	VS	210150
	Jgo. juntas caja velocidades VAUXHALL	VS	210350
	Jgo. juntas retén bancada cigüeñal (2)	SNA	210058
7075064	Junta para cárter	CGT	210060
	Núcleo diferencial EATON 162	NB	350368
	Tapa diferencial EATON 162 A y B	CG	350369
	Jgo. suplemento camisa cilindros (0.07) (6)	CU	1 210170-0.07
	Jgo. suplemento camisa cilindros (0.10) (6)	CU	210170-0.10
	Arandela tapón cárter A 18 x 23 x 1,5 C	CU	
	Kit de retenes completo		R210000
	Jgo. retén válvulas (12)	P	1 R300010P
	Retén bancada 118 x 143 x 13	N	1 R210011N
	Retén distribuidor 49.2 x 65.09 x 12.70	N	1 R210012N

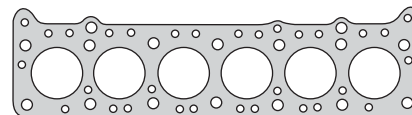

210005

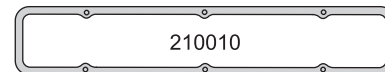

210010

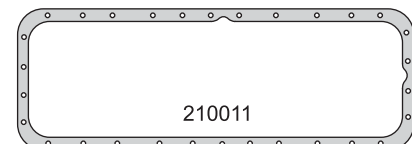

210011

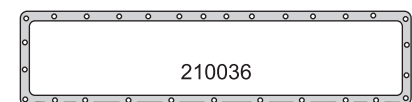

210036

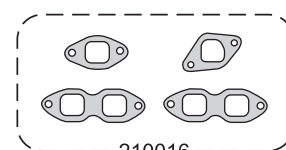

210016



210017

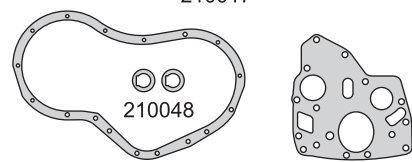

210048

210013

210012



210014

210018

210019

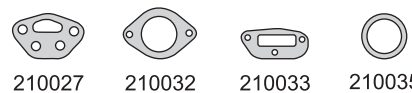

210027

210032

210033

210035

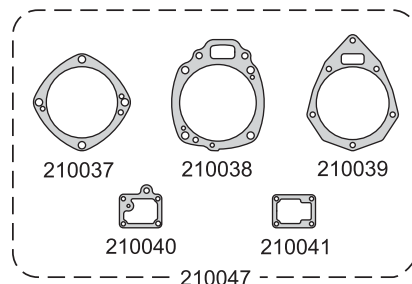

210037

210038

210039

210040

210041

210047



400146

210058



210070-0.07



R210011N

R210012N



R300010P

BEDFORD



Motor/Engine	Cm³	HP	Ø
350D - CD600	5755	137	106.4

Chevrolet: 350H - C60 - 714 1971/79

DIESEL



Nº OE	Descripción/Description	Mat.	Ref.
	Jgo. de juntas para motor		210100-R
6397318	Junta tapa cilindros Ø 110 \pm 1.90	FCH 1	210105
7137894	Junta tapa válvulas	CG 1	210010
7075064	Junta para cárter	CG 1	210011
6322449	Tapa distribución	CG 1	210012
6322652	Placa distribución	NH 1	210013
7126032	Bomba de agua	NH 1	210014
9309	Jgo. múltiple escape (4)	NFT 1	210016
7135808	Múltiple admisión	NH 1	210017
7115805	Salida de escape	FCH 1	210018
7126030	Bomba de agua a block	NH 1	210019
7143049	Bomba aceite a block	NH 1	210027
6303254	Tapa termostato	NH 1	210032
7075136	Codo agua	CB 1	210033
1530250	Tapa filtro aceite	CG 1	210035
7133433	Tapa válvula lateral	CG 1	210036
6337135	Tapa trasera bomba vacío	NH 1	210037
6353757	Placa bomba vacío	NH 1	210038
6353753	Extremo mando bomba vacío	NH 1	210039
7140434	Placa tapa superior bomba	NH 1	210040
7140429	Cuerpo válvula entrada	NH 1	210041
6322449	Tapa distribución	CGT	210045
	Comando bomba combustible	NB 1	400146
	Jgo. juntas depresor (5)	VS 1	210047
	O´ring paso aceite tapa cilindros G 18.64 x 3.53	GS 2	210147
7137885	Buje placa distribución	GS 2	210048
	O´ring paso aceite tapa cilindros G 13.87 x 3.53	GS 1	210148
	Jgo. juntas caja velocidades FAE 5ta.	VS	210150
	Jgo. juntas retén bancada cigüeñal (2)	SNA	210058
7075064	Junta para cárter	CGT	210060
	Núcleo diferencial EATON 162	NB	350368
	Tapa diferencial EATON 162 A y B	CG	350369
	Jgo. suplemento camisa cilindros (0.07) (6)	CU 1	210170-0.07
	Jgo. suplemento camisa cilindros (0.10) (6)	CU	210170-0.10
	Arandela tapón cárter A 18 x 23 x 1.5 C	CU	
	Kit de retenes completo		R210000
	Jgo. retén válvulas (12)	P 1	R300010P
	Retén bancada 118 x 143 x 13	N 1	R210011N
	Retén distribución 49.2 x 65.09 x 12.7	N 1	R210012N

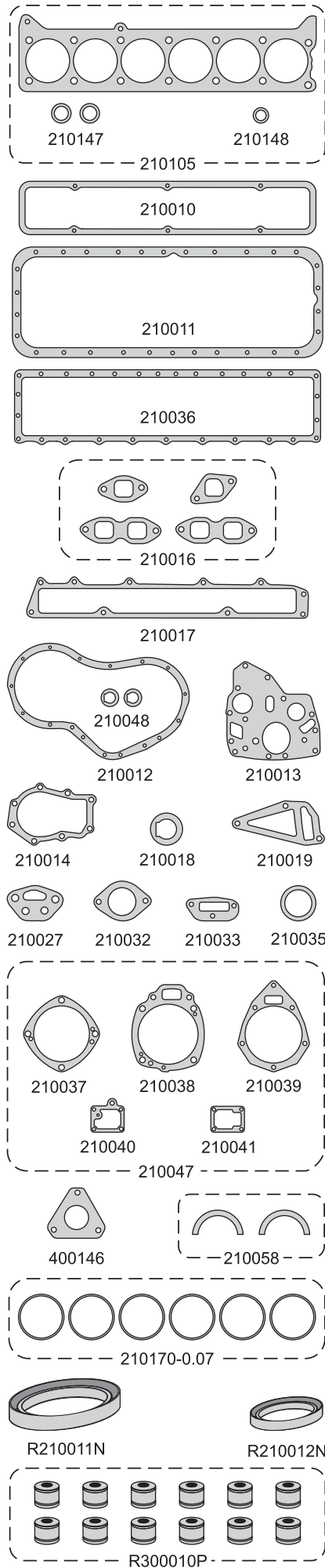

BEDFORD



Motor/Engine	Cm³	HP	Ø
300DX	4927	97	98.3

Chevrolet: C50 Turbo 1971/79



DIESEL

Nº OE	Descripción/Description	Mat.	Ref.
	Jgo. de juntas para motor		210200-R
2637405	Junta tapa cilindros Ø 101 \pm 1.90	FCH 1	210205
7137894	Junta tapa válvulas	CG 1	210010
7075064	Junta para cárter	CG 1	210011
6322449	Tapa distribución	CG 1	210012
6322652	Placa distribución	NB 1	210013
7126032	Bomba de agua	NB 1	210014
9309	Jgo. múltiple escape (4)	NFT 1	210016
7135808	Múltiple admisión	NB 1	210017
7115805	Salida de escape	FCH 1	210018
7126030	Bomba de agua a block	NB 1	210019
7143049	Bomba aceite a block	NB 1	210027
6303254	Tapa termostato	NB 1	210032
7075136	Codo agua	CB 1	210033
1530250	Tapa filtro aceite	CG 1	210035
7133433	Tapa válvula lateral	CG 1	210036
6337135	Tapa trasera bomba vacío	NB 1	210037
6353757	Placa bomba vacío	NB 1	210038
6353753	Extremo mando bomba vacío	NB 1	210039
7140434	Placa tapa superior bomba	NB 1	210040
7140429	Cuerpo válvula entrada	NB 1	210041
6322449	Tapa distribución	CGT	210045
	Comando bomba combustible	NB 1	400146
	Jgo. juntas depresor (5)	VS 1	210047
	O´ring paso aceite tapa cilindros G 18.64 x 3.53	GS 2	210147
7137885	Buje placa distribución	GS 2	210048
	O´ring paso aceite tapa cilindros G 13.87 x 3.53	GS 1	210148
	Jgo. juntas caja velocidades FAE 5ta.	VS	210150
	Jgo. juntas retén bancada cigüeñal (2)	SNA	210058
7075064	Junta para cárter	CGT	210060
	Núcleo diferencial EATON 162	NB	350368
	Tapa diferencial EATON 162 A y B	CG	350369
	Jgo. suplemento camisa cilindros (0.07) (6)	CU 1	210170-0.07
	Jgo. suplemento camisa cilindros (0.10) (6)	CU	210170-0.10
	Arandela tapón cárter A 18 x 23 x 1.5 C	CU	
	Kit de retenes completo		R210000
	Jgo. retén válvulas (12)	P 1	R300010P
	Retén bancada 118 x 143 x 13	N 1	R210011N
	Retén distribuidor 49.2 x 65.09 x 12.7	N 1	R210012N

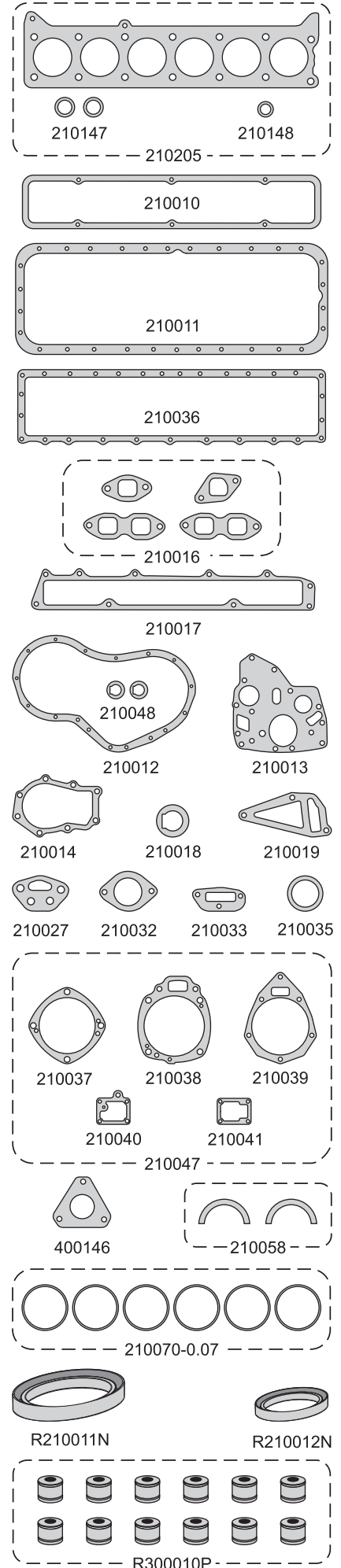

BEDFORD



Motor/Engine	Cm³	HP	Ø
300D	4927	97	98.3

Chevrolet: J6 1956/61



DIESEL

Nº OE	Descripción/Description	Mat.	Ref.
	Jgo. de juntas para motor		210300-R
	Junta tapa cilindros Ø 101.5 ± 1.70	FCH 1	210305
7137894	Junta tapa válvulas superior	CG 1	210010
7075064	Junta para cárter	CG 1	210011
6322449	Tapa distribución	CG 1	210012
6322652	Placa distribución	NB 1	210013
7126032	Tapa bomba de agua	NB 1	210014
9309	Jgo. múltiple escape (4)	NFT 1	210016
7135808	Múltiple admisión	NB 1	210017
7115805	Salida de escape	FCH 1	210018
7126030	Bomba de agua a block	NB 1	210019
7143019	Bomba aceite	NB 1	210027
6303254	Termostato tapa	NB 1	210032
7075136	Codo agua	CB 1	210033
1530250	Tapa filtro aceite	CG 1	210035
7133433	Tapa válvula lateral	CG 1	210036
6337135	Tapa trasera bomba vacío	NB 1	210037
6353757	Placa bomba vacío	NB 1	210038
6353753	Extensión mando bomba vacío	NB 1	210039
7140434	Placa tapa superior bomba	NB 1	210040
7140429	Cuerpo válvula entrada	NB 1	210041
6322449	Tapa distribución	CGT	210045
	Comando bomba combustible	NB 1	400146
	Jgo. juntas depresor (5)	VS 1	210047
7137885	Buje paso aceite distribución	GS 2	210048
	Jgo. juntas caja velocidades FAE 5ta	VS	210150
	Jgo. juntas caja velocidades VAUXHALL	VS	210350
	Jgo. empaquetadura cigüeñal (2)	SNA	210058
7075064	Junta para cárter	CGT	210060
	Núcleo diferencial EATON 162	NB	350368
	Tapa diferencial EATON 162 A y B	CG	350369
	Jgo. suplemento camisa cilindros (0.07) (6)	CU 1	210170-0.07
	Jgo. suplemento camisa cilindros (0.10) (6)	CU	210170-0.10
	Arandela tapón cárter A 18 x 23 x 1.5 C	CU	
	Kit de retenes completo		R210000
	Jgo. retén válvulas (12)	P 1	R300010P
	Retén bancada 118 x 143 x 13	N 1	R210011N
	Retén distribución 49.20 x 65.09 x 12.70	N 1	R210012N

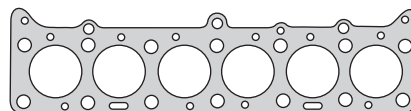

210305



210010

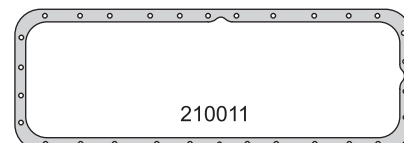

210011

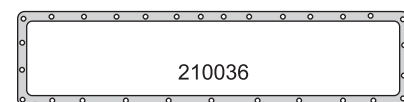

210012

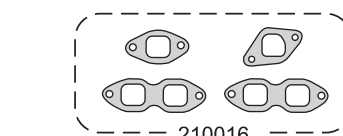

210013

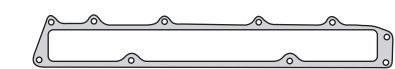

210014

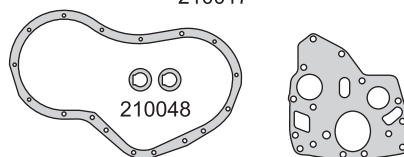

210016



210017



210036



210037



210038

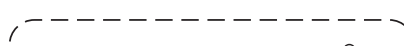

210039



210040



210041

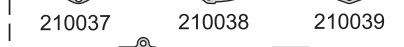

400146



210047



210048

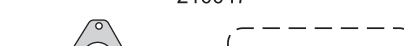

210150



210350



210058



210060



350368

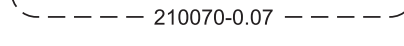

350369



210170-0.07



210170-0.10

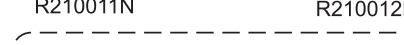

R210000



R300010P



R210011N



R210012N

BEDFORD



Motor/Engine	Cm³	HP	Ø
200D	3285	62	98.3

Chevrolet: C14 - J17 - J27 - J37
1962/64



DIESEL

Nº OE	Descripción/Description	Mat.	Ref.
	Jgo. de juntas para motor		● 210800-R
6362799	Junta tapa cilindros Ø 101.5 ± 1.70	NFT	1 210805
7141212	Junta tapa válvulas superior	CG	1 210410
7135374	Junta para cárter	CG	1 210411
6322449	Tapa distribución	CG	1 210012
6322652	Placa distribución	NB	1 210013
7126032	Bomba de agua	NB	1 210014
	Jgo. múltiple escape (4)	NFT	1 210016
7135809	Múltiple admisión	NB	1 210817
5748788	Salida de escape	NFT	1 200018
3701777	Junta termostato	CB	1 200019
7126030	Bomba agua a block	NB	1 210019
	Codo agua	CB	1 210033
7135794	Tapa válvula lateral	CG	1 210436
6322449	Tapa distribución	CGT	210045
7137885	Buje placa distribución	GS	2 210048
	Jgo. empaquetadura cigüeñal (2)	SNA	210058
	Jgo. suplemento camisa cilindros 0.07 (4)	CU	1 210170-0.07
	Jgo. suplemento camisa cilindros 0.10 (4)	CU	210170-0.10
	Arandela tapón cárter A 18 x 27 x 1.5 C	CU	
	Kit de retenes completo		R210400
	Jgo. retén válvulas (8)	P	1 R210010P
	Retén bancada 118 x 143 x 13	N	1 R210011N
	Retén distribución 49.20 x 65.09 x 12.70	N	1 R210012N

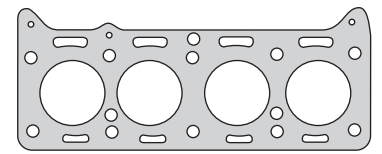

210805

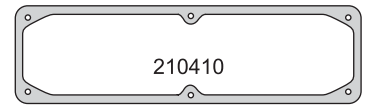

210410

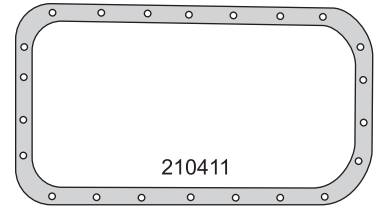

210411

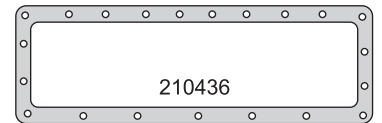

210436



210817

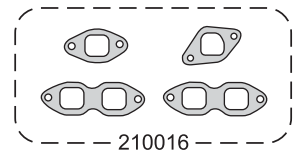

210016

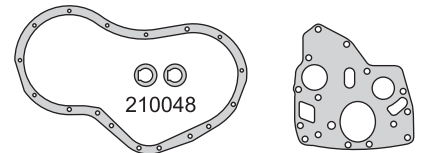

210048

210012

210013

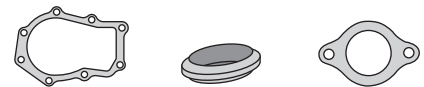

210014

200018

200019

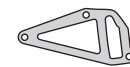

210019



210033



210070-0.07

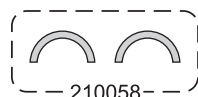

210058



R210011N



R210012N



R210010P



taranto



KIT HAK639512-111 Taranto.

Práctico Juego de llaves combinadas para Taller.

- ▶ Contiene 111 Tubos y llaves SmarDriv encastre 1/4", 3/8" y 1/2"
- ▶ Forjados en acero especial, niquelados y cromados anticorrosión.
- ▶ Diseñados y fabricados con un rango de medidas acorde a las necesidades de cada pieza.



CIMARRON



Motor/Engine **3300D** Cm³ **3285** HP **88** Ø **98.3**

Cimarron: 1976/85

DIESEL



Nº OE	Descripción/Description	Mat.	Ref.
	Jgo. de juntas para motor		210400-R
	Junta tapa cilindros Ø 101 ± 1.40	NFT 1	210405
20601	Junta tapa válvulas superior	CG 1	210410
10607	Junta para cárter	CG 1	210411
30602	Tapa distribución	CG 1	210012
30603	Placa distribución	NB 1	210413
20606	Bomba de agua	NB 1	210014
20602	Jgo. múltiple escape (2)	NFT 1	210416
10611/12	Jgo. múltiple admisión (3)	CB 1	210417
	Jgo. múltiple admisión (3)	CB	210517
3701777	Junta termostato	CB 1	200019
20605	Bomba agua a block	NB 1	210019
10605	Filtro aceite	NB 1	210427
10606	Bomba combustible	NB 1	210428
	Salida de escape	FCH 1	300230
20607	Caja termostato	CB 1	210033
10613	Tapa lateral	CG 1	210436
6337135	Tapa trasera bomba vacío	NB 1	210037
6353757	Placa bomba vacío	NB 1	210038
50601	Mando bomba inyectora	NB 1	210039
7140434	Placa tapa superior bomba	NB 1	210040
7140429	Cuerpo válvula entrada	NB 1	210041
50603	Comando bomba combustible	NB 1	400146
	Jgo. juntas depresor (5)	VS 1	210047
10620	Tubo venteo	NB 1	210447
7137885	Buje pasa aceite distribución	GS 2	210048
20608	Salida agua	CB	210448
50602	Soporte bomba inyectora	NB 2	210449
	Arandela tapón cárter A 18 x 23 x 1.5 C	CU	
	Kit de retenes completo		R210400
	Jgo. retén válvulas (8)	P 1	R210010P
	Retén bancada 118 x 143 x 13	N 1	R210011N
	Retén distribución 49.20 x 65.09 x 12.70	N 1	R210012N

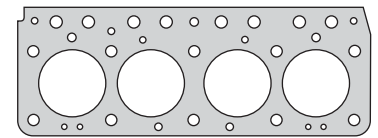

210405

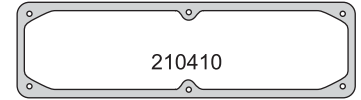

210410

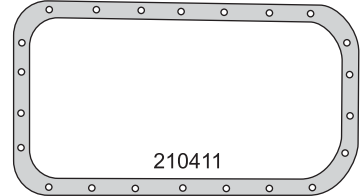

210411

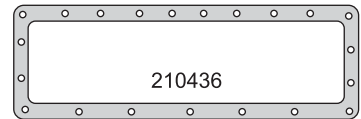

210436

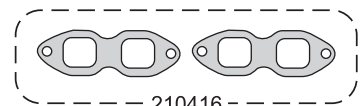

210416

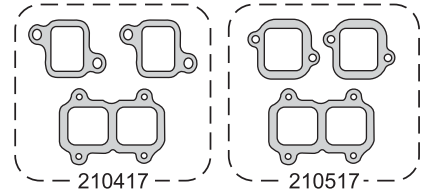

210417

210517

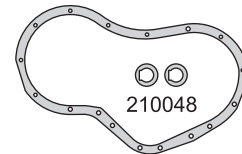

210048

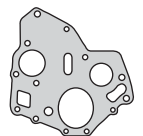

210413



210012



210014

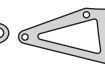

200019



210019

210427



210428



210033



400146



210447

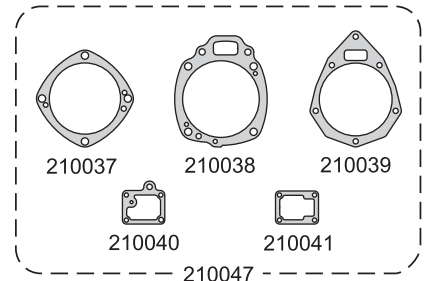

210047



210448



210449



300230



R210011N



R210012N

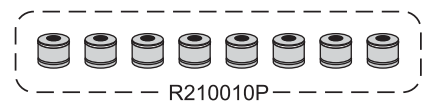

R210010P

CIMARRON



Motor/Engine	Cm³	HP	Ø
3300D	3283	89	98.42

Cimarron: 1986/...

DIESEL



Nº OE	Descripción/Description	Mat.	Ref.
	Jgo. de juntas para motor		210500-R
	Junta tapa cilindros Ø 101 \pm 1.40	NFT	1 210505
20601	Junta tapa válvulas superior	CG	1 210410
20664	Junta para cárter	NB	1 210511
30602	Tapa distribución	CG	1 210012
30603	Placa distribución	NB	1 210413
20606	Bomba de agua	NB	1 210014
20602	Jgo. múltiple escape (2)	NFT	1 210416
10611/12	Jgo. múltiple admisión (3)	CB	1 210417
	Jgo. múltiple admisión (3)	CB	210517
3701777	Junta termostato	CB	1 200019
20605	Bomba agua a block	NB	1 210019
10605	Filtro aceite	NB	1 210427
10606	Bomba combustible	NB	1 210428
	Salida de escape	FCH	1 300230
20607	Caja termostato	CB	1 210033
10610	Tapa lateral	NB	1 210536
6337135	Tapa trasera bomba vacío	NB	1 210037
6353757	Placa bomba vacío	NB	1 210038
50601	Mando bomba inyectora	NB	1 210039
7140434	Placa tapa superior bomba	NB	1 210040
7140429	Cuerpo válvula entrada	NB	1 210041
50603	Comando bomba combustible	NB	1 400146
	Jgo. juntas depresor (5)	VS	1 210047
10620	Tubo venteo	NB	1 210447
7137885	Buje placa distribución	GS	2 210048
20608	Salida agua	CB	1 210448
50602	Soporte bomba inyectora	NB	2 210449
	Arandela tapón cárter A 18 x 23 x 1.5 C	CU	
	Kit de retenes completo		R210400
	Jgo. retén válvulas (8)	P	1 R210010P
	Retén bancada 118 x 143 x 13	N	1 R210011N
	Retén distribución 49.20 x 65.09 x 12.70	N	1 R210012N

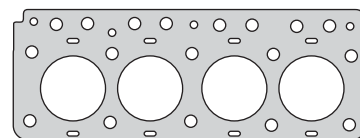

210505

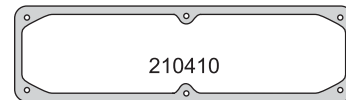

210410

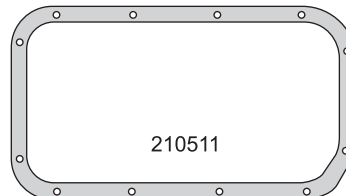

210511

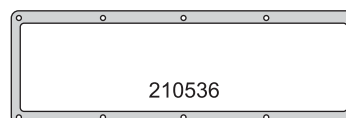

210536

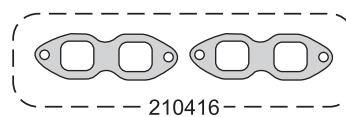

210416

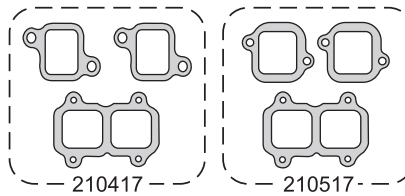

210417

210517

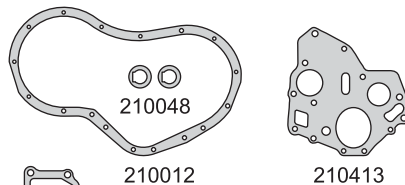

210048

210413

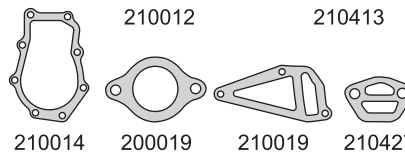

210012

210014

200019

210019

210427

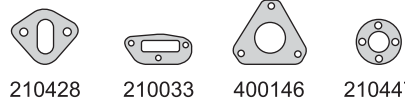

210428

210033

400146

210447

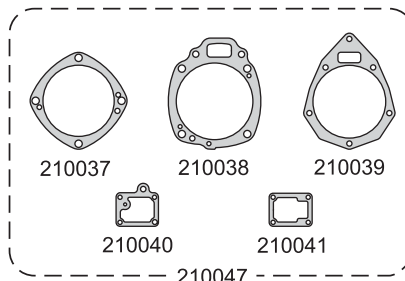

210037

210038

210039

210040

210041

210047

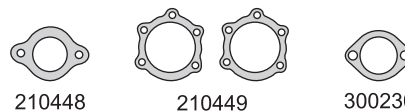

210448

210449

300230



R210011N

R210012N



R210010P

CIMARRON



Motor/Engine	Cm³	HP	Ø
3800D	3840	99	106.4

Cimarron: 1979/85



DIESEL

Nº OE	Descripción/Description	Mat.	Ref.
	Jgo. de juntas para motor		210600-R
	Junta tapa cilindros Ø 109.5 ± 1.40	NFT	1 210605
20601	Junta tapa válvulas superior	CG	1 210410
10607	Junta para cárter	CG	1 210411
30602	Tapa distribución	CG	1 210012
30603	Placa distribución	NB	1 210413
20606	Bomba de agua	NB	1 210014
20602	Jgo. múltiple escape (2)	NFT	1 210416
10611/12	Jgo. múltiple admisión (3)	CB	1 210417
	Jgo. múltiple admisión (3)	CB	210517
3701777	Junta termostato	CB	1 200019
20605	Bomba agua a block	NB	1 210019
10605	Filtro aceite	NB	1 210427
10606	Bomba combustible	NB	1 210428
	Salida de escape	FCH	1 300230
20607	Caja termostato	CB	1 210033
10613	Tapa lateral	CG	1 210436
6337135	Tapa trasera bomba vacío	NB	1 210037
6353757	Placa bomba vacío	NB	1 210038
50601	Mando bomba inyectora	NB	1 210039
7140434	Placa tapa superior bomba	NB	1 210040
7140429	Cuerpo válvula entrada	NB	1 210041
50603	Comando bomba combustible	NB	1 400146
	Jgo. juntas depresor (5)	VS	1 210047
10620	Tubo venteo	NB	1 210447
7137885	Buje placa distribución	GS	2 210048
20608	Salida agua	CB	210448
50602	Soporte bomba inyectora	NB	2 210449
	Arandela tapón cárter A 18 x 23 x 1.5 C	CU	
	Kit de retenes completo		R210400
	Jgo. retén válvulas (8)	P	1 R210010P
	Retén bancada 118 x 143 x 13	N	1 R210011N
	Retén distribución 49.20 x 65.09 x 12.70	N	1 R210012N

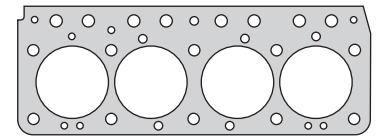

210605

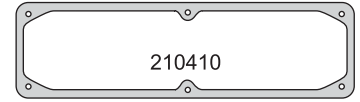

210410

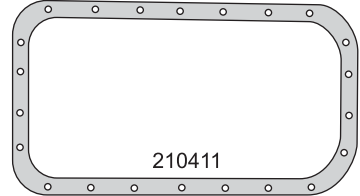

210411

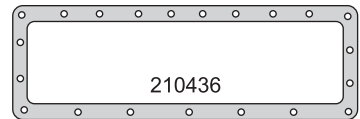

210436

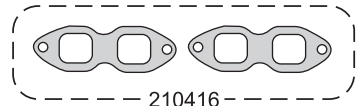

210416

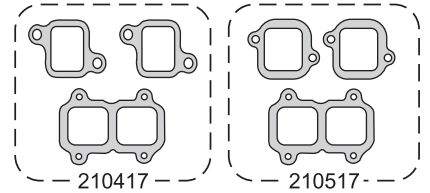

210417

210517

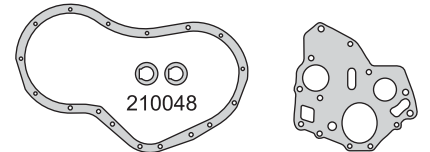

210048

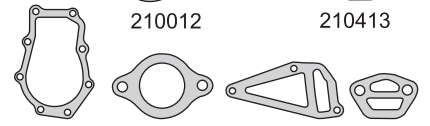

210012

210413

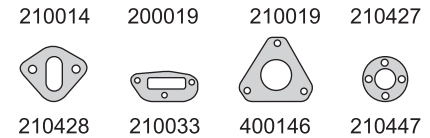

210014

200019

210019

210427

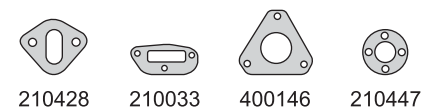

210428

210033

400146

210447

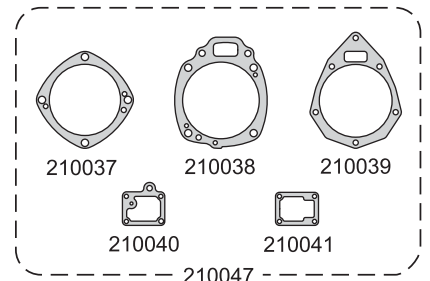

210037

210038

210039

210040

210041

210047

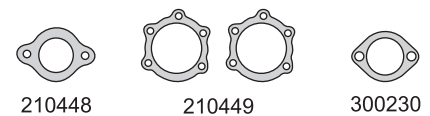

210448

210449

300230



R210011N

R210012N

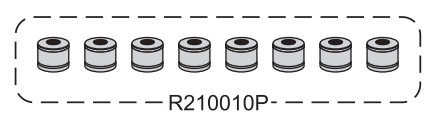

R210010P

CIMARRON



Motor/Engine	Cm³	HP	Ø
3800D	3840	99	106.4

Cimarron: 1986/...

DIESEL



CIMARRON

Nº OE	Descripción/Description	Mat.	Ref.
	Jgo. de juntas para motor		210700-R
	Junta tapa cilindros Ø 109.5 ± 1.40	NFT	1 210705
20601	Junta tapa válvulas superior	CG	1 210410
20664	Junta para cárter	NB	1 210511
30602	Tapa distribución	CG	1 210012
30603	Placa distribución	NB	1 210413
20606	Bomba de agua	NB	1 210014
20602	Jgo. múltiple escape (2)	NFT	1 210416
10611/12	Jgo. múltiple admisión (3)	CB	1 210417
	Jgo. múltiple admisión (3)	CB	210517
3701777	Junta termostato	CB	1 200019
20605	Bomba de agua a block	NB	1 210019
10605	Filtro aceite	NB	1 210427
10606	Bomba combustible	NB	1 210428
	Salida de escape	FCH	1 300230
20607	Caja termostato	CB	1 210033
10610	Tapa lateral	NB	1 210536
6337135	Tapa trasera bomba vacío	NB	1 210037
6353757	Placa bomba vacío	NB	1 210038
50601	Mando bomba inyectora	NB	1 210039
7140434	Placa tapa superior bomba	NB	1 210040
7140429	Cuerpo válvula entrada	NB	1 210041
50603	Comando bomba combustible	NB	1 400146
	Jgo. juntas depresor (5)	VS	1 210047
10620	Tubo venteo	NB	1 210447
7137885	Buje placa distribución	GS	2 210048
20608	Salida agua	CB	210448
50602	Soporte bomba inyectora	NB	2 210449
	Arandela tapón cárter A 18 x 23 x 1.5 C	CU	
	Kit de retenes completo		R210400
	Jgo. retén válvulas (8)	P	1 R210010P
	Retén bancada 118 x 143 x 13	N	1 R210011N
	Retén distribución 49.20 x 65.09 x 12.70	N	1 R210012N

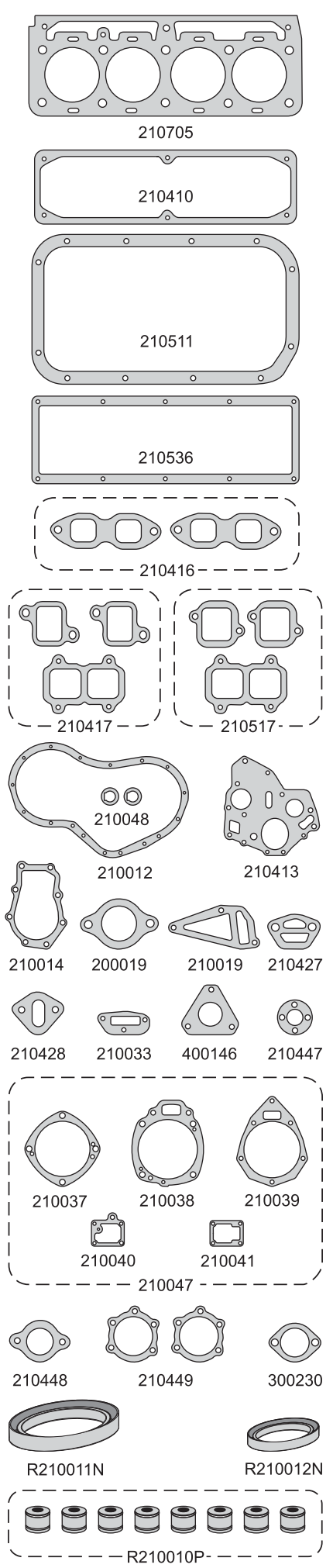

CUMMINS**taranto**

Motor/Engine	Cm³	HP	Ø
4B	3900	100	102
4BT/BTA	3900	130	102

Cummins: Serie B
Ford: F100 1998/... - F4000 2000/...
 Cargo 915 - Euro II



DIESEL

Nº OE	Descripción/Description	Mat.	Ref.
	Jgo. de juntas para motor		870000-R
	Jgo. de juntas superior		870095
BF6T/6051/AB	Jta. tapa cilindros Ø 106 \pm 1.60	NFT	1 1 870007
	Jgo. de tornillos para tapa de cilindros		B870000
BF6T/6584/AA	Conj. junta tapa válvulas (2)	GS	4 4 870010
BF8T/6L680/AA	Junta para cárter	NB	1 1 870011
BF5X/6020/B	Tapa distribución con bomba rotativa	NFT	1 1 870012
BF5X/6020/C	Placa distribución con bomba lineal	NB	1 1 870013
3927154/00	Múltiple escape	AC	4 4 870015
BF8T/9441/AA	Múltiple admisión	NB	1 1 870017
	Salida de escape	AC	1 1 870018
BF9T/9W352/A	Base bomba alimentación	NB	1 1 870028
BF5X/9L937/AA	Separador admisión	NB	2 2 870029
BF8T/8255/A	Guarnición termostato	GS	1 1 870030
	Anular G 30 x 46 x 3	GS	1 1 510535
	Guarnición G 68 x 72 x 1.7	GS	1 1 870032
	Arandela doble raccord Ø6	CU	4 4 870034
BF8T/6L621/A	Placa enfriador aceite intermedia	NFT	1 1 870035
BF8T/6C519/A	Lateral botadores	CG	1 1 870036
3918493	Porta retén bancada trasero	NB	1 1 870037
	Placa enfriador aceite intermedia	NFT	1 1 870038
BF6X/6838/A	Placa enfriador aceite a block	NB	1 1 870039
	Boquilla plást. cortas surtidor aceite bancada	P	4 4 870041
3925 235/A	Placa cobre volante	CG	1 1 870042
BF8T/6659/AA	Succión aceite	NB	1 1 870043
BF5X/9585/A	Base bomba inyectora	NB	1 1 870044
2RL/145617	Junta compresor	NFT	1 1 870045
3916042	Junta bomba inyectora distribución	NFT	1 1 870046
BF8T/6A25/A	Inspección trasera distribución	NB	1 1 870047
	Brida entrada servo		870048
	Boquillas plást. largas surtidor aceite bancada	P	4 4 870049
	Sello con inserto metálico G 65 x 73 x 3	GS	1 1 870051
	Jgo. juntas caja de velocidades	VS	1 1 870050
	Guarnición tapa válvulas G 10 x 18 x 10	GS	4 4 870052
TRA/145453	Colector a escape turbo	AC	1 1 870063
BF0T/6N652/AA	Salida aceite a turbo	NH	1 1 870064
	Buje con ala A 7 x 15 x 9 C	CU	1 1 870065
	Junta inspección	NB	1 1 870068
	Arandela especial con inserto A 8 x 18 x 0.5 C	CU	1 6
	Arandela A 22 x 27 x 1.5 C	CU	1 1
	Arandela A 22 x 27 x 1.5 A	AL	1 4
	Arandela A 10 x 16 x 1.5 C	CU	4 6
	Arandela A 7 x 15 x 2.5 C	CU	2 6
	Arandela A 7 x 15 x 1.5 C	CU	4 4
	Arandela A 18 x 24 x 1.5 C	CU	1 1
	Arandela A 25 x 29 x 2 C	CU	1 1
	Arandela especial con inserto A 8 x 13 x 1 C	CU	2 2
	O´ring G 9.25 x 1.78	GS	6 6
	O´ring G 15.6 x 1.78	GS	1 1
	Anillo G 158 x 166 x 7 guarda polvo retén trasero	GS	1 1
	Anillo G 88 x 99 x 5	GS	1 1
	Anillo G 73 x 84 x 9	GS	1 1
	Anillo G 50 x 62 x 5	GS	1 1

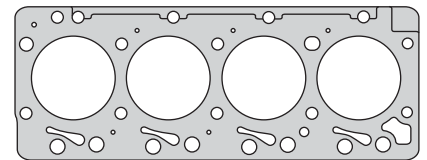

870007

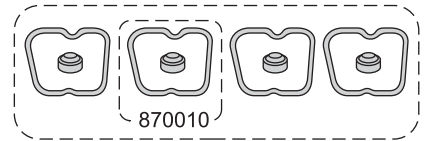

870010

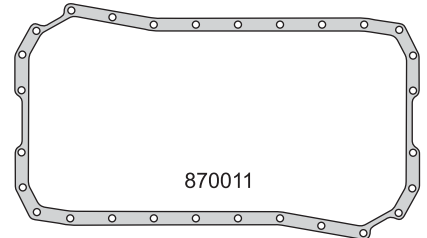

870011



870036



870015

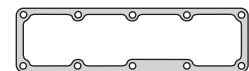

870017

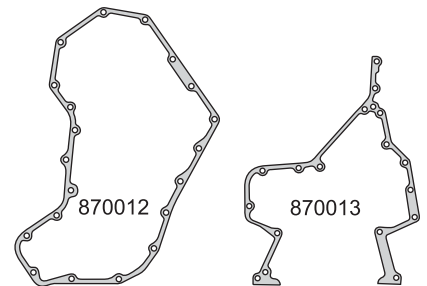

870012

870013

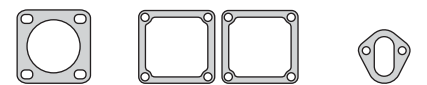

870018

870029

870028

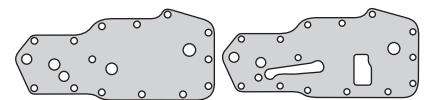

870035

870038

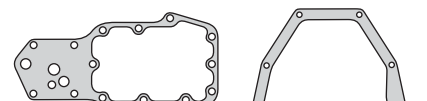

870039

870037



870034

870041

870049

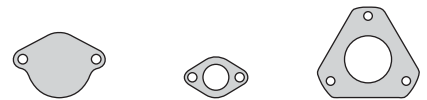

870042

870043

870044

CUMMINS



Motor/Engine	Cm³	HP	Ø
4B	3900	100	102
4BT/BTA	3900	130	102

Cummins: Serie B
Ford: F100 1998/... - F4000 2000/...
 Cargo 915 - Euro II



DIESEL

Nº OE	Descripción/Description	Mat.	1	Ref.
	Anillo G 41 x 47 x 2.5	GS	1	
	Anillo G 30 x 34 x 2	GS	1	
	Anillo G 25 x 29 x 1.5	GS	1	
	Kit de retenes completo			R870000
BF8T/6377/AA	Jgo. retén válvulas (8)	P	1	R870010P
BF8T/6378/AA	Retén bancada 130 x 150 x 12/13	VF	1	R870011VF
BF5X/6571/AA	Retén distribución 63.5 x 79.5 x 9	VF	1	R870012VF

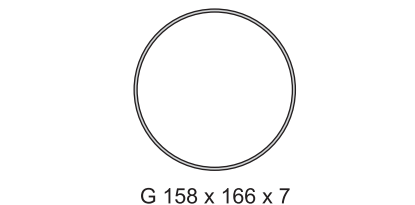
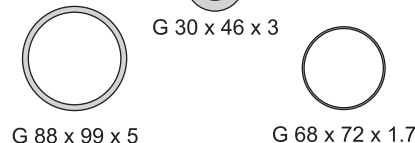
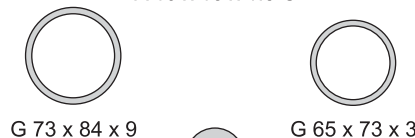
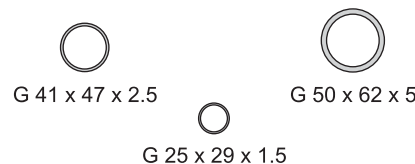
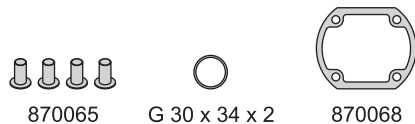
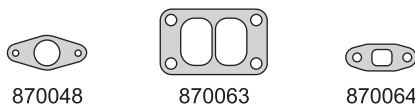
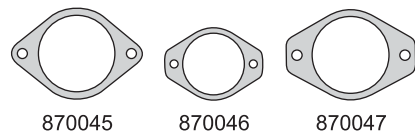

CUMMINS

CUMMINS



Motor/Engine	Cm³	HP	Ø
6B	5883	330	102
6B	5900	180	102
6BT/BTA	5900	205	102

Cummins: Serie B
Dodge: Truck 359 1989/93 - Ram 2007/...
Ford: F14000 - Turbo - F4000 1999/...
 1416 Euro I 1989/93



DIESEL

Nº OE	Descripción/Description	Mat.	Ref.
	Jgo. de juntas para motor		870100-R
	Jgo. de juntas superior		870195
BF5X/6051/AA	Jta. tapa cilindros Ø 106 \pm 1.60	NFT	1 1 870107
	Jgo. de tornillos para tapa de cilindros		B870100
BF6T/6584/AA	Conj. junta tapa válvulas (2)	GS	6 6 870010
BF0T/6710/AA	Junta para cárter	NB	1 1 870111
BF5X/6020/B	Tapa distribución con bomba rotativa	NFT	1 1 870012
	Tapa distribución con bomba lineal	NFT	1 1 870112
BF5X/6020/C	Placa distribución	NB	1 1 870013
3927154/00	Múltiple escape	AC	6 6 870015
TRA/129717	Múltiple admisión	NB	1 1 870117
	Salida de escape	AC	1 1 870018
BF9T/9W352/A	Bomba combustible	NB	1 1 870028
BF5X/9L937/AA	Separador admisión	NB	2 2 870029
BF8T/8255/A	Guarnición termostato	GS	1 1 870030
	Anular G 30 x 46 x 3	GS	1 1 510535
	Guarnición G 68 x 72 x 1.7	GS	1 1 870032
	Arandela especial A 10 x 16 x 1.5 C	CU	6 6 870133
	Arandela doble raccord Ø6	CU	6 6 870034
BF8T/6L621/A	Tapa enfriador aceite	NFT	1 1 870035
13928832/00	Tapa lateral botadores	CG	1 1 870136
	Porta retén bancada trasero	NB	1 1 870037
	Placa enfriador aceite intermedio	NFT	1 1 870038
BF6X/6838/A	Placa enfriador aceite	NB	1 1 870039
	Boquilla plástica surtidor aceite bancada	PLAST	6 6 870041
3925 235/A	Placa tapa cubrevolante	CG	1 1 870042
BF8T/6659/AA	Succión aceite	NB	1 1 870043
BF5X/9585/A	Base bomba inyectora	NB	1 1 870044
2RL/145617	Junta compresor	NFT	1 1 870045
3916042	Junta bomba inyectora a distribución	NFT	1 1 870046
BF8T/6A025/A	Bomba inyectora a distribución	NB	1 1 870047
	Boquillas plásticas largas surtidor aceite bancada	PLAST	6 6 870049
	Guarnición tapa válvulas G 10 x 18 x 10	GS	6 6 870052
TRA/145453	Colector a escape turbo	AC	1 1 870063
BF0T/6N652/AA	Salida aceite a turbo	NB	1 1 870064
	Junta inspección	NB	1 1 870068
	Arandela A 22 x 27 x 1.5 A	AL	4 1
	Arandela A 22 x 27 x 1.5 C	CU	1 1
	Arandela A 18 x 24 x 1.5 C	CU	1 1
	Arandela A 25 x 29 x 2 C	CU	1 1
	Arandela A 7 x 15 x 2.5 C	CU	6 6
	Arandela A 7 x 15 x 1.5 C	CU	4 1
	Arandela A 8 x 13 x 1 C	CU	2 1
	Arandela A 8 x 18 x 0.5 C	CU	6 1
	O'ring G 9.25 x 1.78	GS	6 1
	O'ring G 15.6 x 1.78	GS	1 1
	Anillo G 158 x 166 x 7 guarda polvo retén trasero	GS	1 1
	Anillo G 88 x 99 x 5	GS	1 1
	Anillo G 73 x 84 x 9	GS	1 1
	Anillo G 50 x 62 x 5	GS	1 1
	Anillo G 41 x 47.5 x 2.5	GS	1 1
	Anillo G 30 x 34 x 2	GS	1 1
	Anillo G 25 x 29 x 1.5	GS	1 1

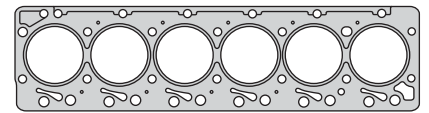

870107

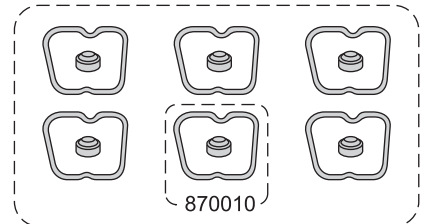

870010

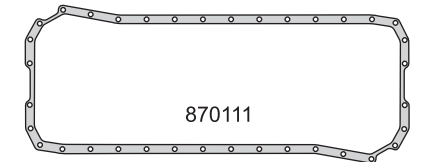

870111



870136

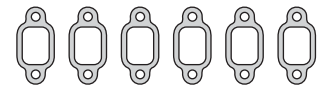

870015

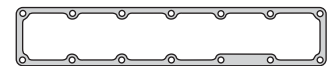

870117

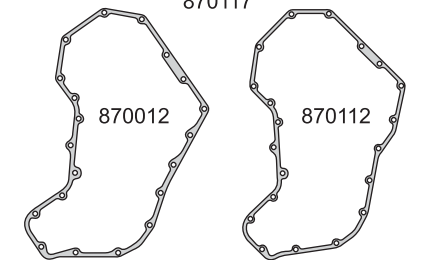

870012

870112

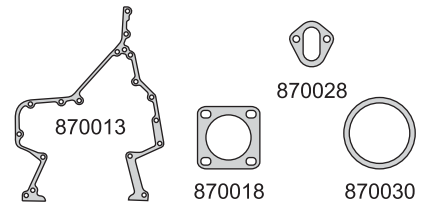

870013

870028

870018

870030

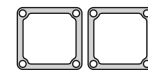

870029



870034

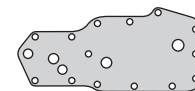

870035

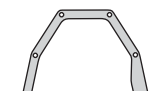

870037

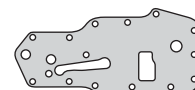

870038

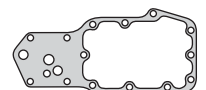

870039



870041



870043

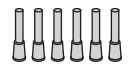

870049



870042



870045



870044

CUMMINS

CUMMINS



Motor/Engine	Cm³	HP	Ø
6B	5883	330	102
6B	5900	180	102
6BT/BTA	5900	205	102

Cummins: Serie B
Dodge: Truck 359 1989/93 - Ram 2007/...
Ford: F14000 - Turbo - F4000 1999/...
 1416 Euro I 1989/93



DIESEL

Nº OE	Descripción/Description	Mat.	Ref.
	Kit de retenes completo		R870100
BF5X/6571/AA	Jgo. retén válvulas (12)	P	1 R870110P
BF8T/6377/AA	Retén bancada 130 x 150 x 12/13	VF	1 R870011VF
BF8T/6378/AA	Retén distribución 63.5 x 79.5 x 9	VF	1 R870012VF

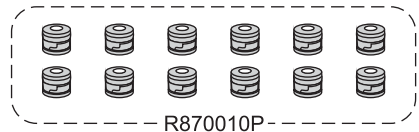
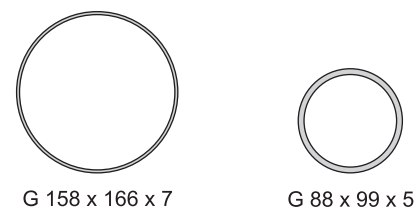
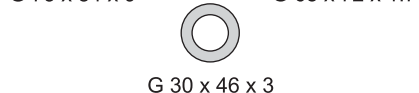
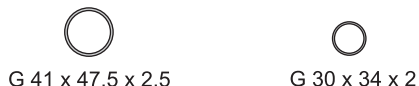
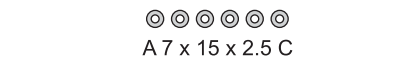
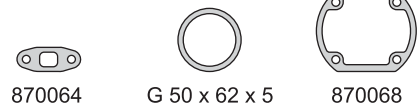
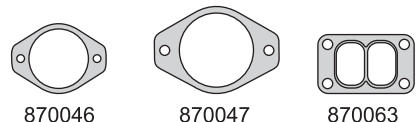

CUMMINS

CUMMINS



Motor/Engine	Cm³	HP	Ø
6C	8300	254	114
6CT/CTA	8300	294	114

Cummins: Serie C - Bus - Camión - Agrícola
Ford: Cargo 1722 - 1730 - 2625 1998/...
 F14000 1999/...



DIESEL

Nº OE	Descripción/Description	Mat.	Ref.
	Jgo. de juntas para motor		870200-R
	Jgo. de juntas superior		870295-R
3935585-3938267	Jta. tapa cilindros Ø 120 \pm 1.50 N.R.	NFT 1 1	870207
	Jgo. de tornillos para tapa de cilindros		B870200
3905449	Junta tapa válvulas	GS 1 1	870210
3914017	Junta para cárter	NB 1 1	870211
3917779	Tapa distribución	NFT 1 1	870212
3914304	Placa distribución	NFT 1 1	870213
3932063	Jgo. múltiple escape (6)	AC 1 1	870215
3921440	Múltiple admisión	NB 1 1	870217
3914210	Termostato	NB 1 1	870219
3911941	Turbo	NB 1 1	870220
	Turbo intermedia	NB 1 1	870221
	Turbo salida de escape	AC 1 1	870222
3823921	Turbo entrada aceite	NB 1 1	870223
3906886	Capuchón protector inyector	P 6 6	870225
3902466	Arandela goma G 14 x 19 x 2.5	GS 1 1	870226
3914708	Chapa fijadora prisionero múltiple escape	AC 12 12	870227
3935172	Arandela con inserto goma	AC/GS	870228
3935171	Arandela con inserto goma	AC/GS 4 4	870229
3914311	Múltiple admisión	NB 1 1	870231
3937706	Llenado aceite	GS	870232
3914301	Porta retén trasero	NB	870233
	Arandela doble raccord Ø6	CU 8 8	870034
3918174	Enfriador aceite a block	NFT	870234
3918332	Placa separador enfriador aceite	NFT	870235
3914308	Placa separador enfriador aceite	NFT	870236
3916042	Bomba hidráulica	NB	870237
3918340	Bomba hidráulica		870238
3914303	Inspección distribución	NFT	870239
3914302	Bomba succión aceite	NFT	870240
3919003	Boquilla plástica enfriador pistón	PLAST	870241
3905928	Boquilla plástica enfriador larga	PLAST	870242
3917780	Tapa distribución - versión nueva - Junta acople admisión	NFT 1 1 NB 1 1	870243 870244
BF8T/6A25/A	Inspección trasera	NB	870047
	Junta inspección	NB	870068
3912473	Anillo goma G 158 x 166 x 7	GS	870243
3906659	Arandela inyector A 7 x 15 x 1.5 C	CU 6 6	870244
3910824	O´ring G 9.25 x 1.78	GS 6 6	870245
3909397	O´ring G 17.17 x 1.78	GS 1 1	870246
145530	O´ring G 23.47 x 2.62	GS 2 2	870247
3903546	O´ring G 69.57 x 1.78	GS 1 1	870248
3902089	O´ring G 98.02 x 3.53	GS	870249
3901798	Anillo goma G 77.2 x 83 x 3	GS	870250
3915772	Anillo goma G 12.5 x 19 x 3	GS	870251
3914095	Anillo goma G 30 x 34 x 2	GS	870252
	O´ring G 61.60 x 2.62	GS	870253
	O´ring G 15.6 x 1.78	GS	870254
	O´ring G 12.37 x 2.62	GS	870255
3902425	Arandela A 25 x 29 x 2 C	CU	870256
	Arandela A 22 x 27 x 1.5 A	AL 3 3	870257
3920773	Arandela A 18 x 24 x 1.5 C	CU	870258

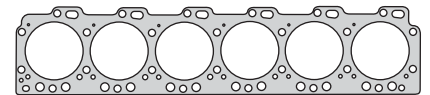

870207

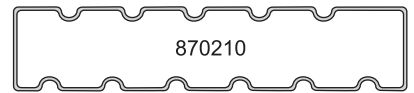

870210

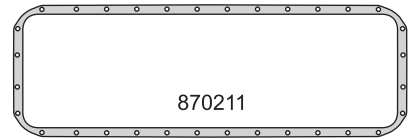

870211



870215

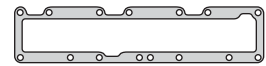

870231

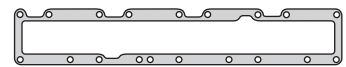

870217

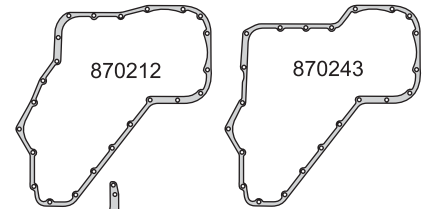

870212

870243

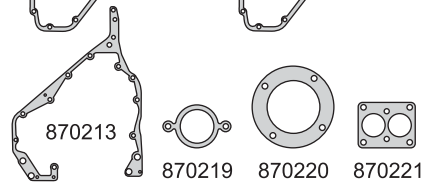

870213

870219

870220

870221



870222

870225

870223

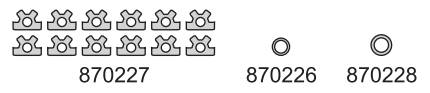

870227

870226

870228



870229

870232



870034

870233

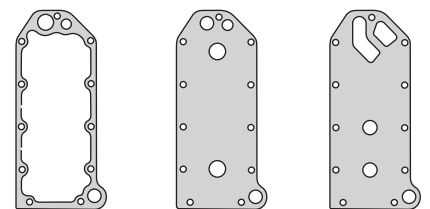

870234

870235

870236



870237

870239

870238



870241

870242

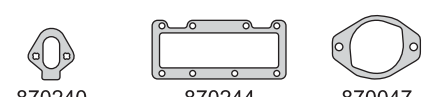

870240

870244

870047

CUMMINS

CUMMINS



Motor/Engine	Cm ³	HP	Ø
6C	8300	254	114
6CT/CTA	8300	294	114

Cummins: Serie C - Bus - Camión - Agrícola
Ford: Cargo 1722 - 1730 - 2625 1998/...
 F14000 1999/...



DIESEL

N° OE	Descripción/Description	Mat.	Ref.
	Arandela A 12 x 18 x 1 HG	HG	2
	Kit de retenes completo		R870200
3927642	Jgo. retén válvulas (12)	V	1 R870210V
3909410	Retén bancada 130 x 150 x 12/13	VF	1 R870011VF
3908139	Retén distribución 75 x 93 x 9/10	V	1 R870212V

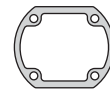

870068



G 69.57 x 1.78



G 77.2 x 83 x 3



G 61.60 x 2.62

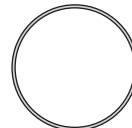

G 158 x 166 x 7



G 98.02 x 3.53



G 23.47 x 2.62



G 30 x 34 x 2



G 17.17 x 1.78



G 9.25 x 1.78



G 12.37 x 2.62



G 12.5 x 19 x 3



G 15.6 x 1.78



A 18 x 24 x 1.5 C



A 25 x 29 x 2 C



A 7 x 15 x 1.5 C



A 22 x 27 x 1.5 A



A 12 x 18 x 1 HG



R870011VF



R870212V

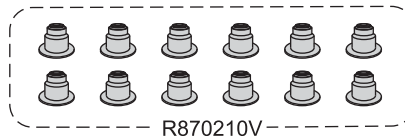

R870210V

CUMMINS

CUMMINS



Motor/Engine	Cm³	HP	Ø
ISBe 16V	3920	150/170	102

Cummins: Bus - Agrale - Euro III/IV
Electrónico 2003/...

Ford: F100 2006/... - Common Rail



DIESEL

Nº OE	Descripción/Description	Mat.	Ref.
	Jgo. de juntas para motor		● 870500-R
2830707	Junta tapa cilindros Ø 105 ± 1.10	NFT	1 870508
	Jgo. de tornillos para tapa de cilindros		B870500
4899228	Junta tapa válvulas superior	GS	1 870510
	Junta tapa válvulas inferior	GS	870536
4897877	Junta para cárter	NH	1 870511
2830444	Jgo. múltiple escape (4)	GFT	1 870516
	Guarnición cierre tapa válvulas	GS	4 870533
4896409	Junta enfriador aceite placa	NFT	1 800835
	Junta	NFT	1 870539
4842146	Guarnición llenado aceite	GS	1 800839
4898301	Junta chupador aceite	NB	1 800841
4891288	Junta entrada aceite a turbo	NB	1 800840
3942454	Guarnición termostato	GS	870543
3932475	Junta escape turbo	AC	1 500546
4893741	Arandela pico inyector A 7.5 x 15 x 3 C	CU	4 870546
	Junta	NFT	1 870547
	Arandela A 7.5 x 15 x 2 C	CU	4
	Arandela A 16 x 24 x 1.5 A	AL	2
	Arandela A 12 x 20 x 1.5 A	AL	
3906252	Guarnición G 105 x 111 x 3.65	GS	1
	O´ring G 7.59 x 2.62	GS	12
	O´ring G 9.19 x 2.62	GS	1
	O´ring G 9 x 2	GS	1
	O´ring G 9.25 x 1.78	GS	2
4890929	O´ring G 10.77 x 2.62	GS	2
	O´ring G 11 x 3	GS	4
	O´ring G 13.94 x 2.62	GS	1
	O´ring G 15.54 x 2.62	GS	2
	O´ring G 15.6 x 1.78	GS	1
	O´ring G 17.12 x 2.62	GS	2
	O´ring G 17.17 x 1.78	GS	1
	O´ring G 18.72 x 2.62	GS	1
	O´ring G 19.18 x 2.46	GS	1
4898439	O´ring G 20.3 x 2.62	GS	1
4890926	O´ring G 21 x 3	GS	4
	O´ring G 23.39 x 3.53	GS	1
	O´ring G 23.47 x 2.62	GS	2
	O´ring G 25.07 x 2.62	GS	1
	O´ring G 44.12 x 2.62	GS	1
	O´ring G 50.39 x 3.53	GS	1
	O´ring G 60.05 x 1.78	GS	1
	O´ring G 82.22 x 2.62	GS	1
	Anillo G 50 x 62 x 5	GS	1
	Anillo G 88 x 99 x 5	GS	1
	Kit de retenes completo		R870500
3945438/1	Jgo. retén válvulas (16)	V	1 R870510V
4890833	Retén bancada 130 x 155 x 12,5/16	T	1 R800811T
4890832	Retén distribución 70 x 100 x 12,5/16	T	1 R800812T

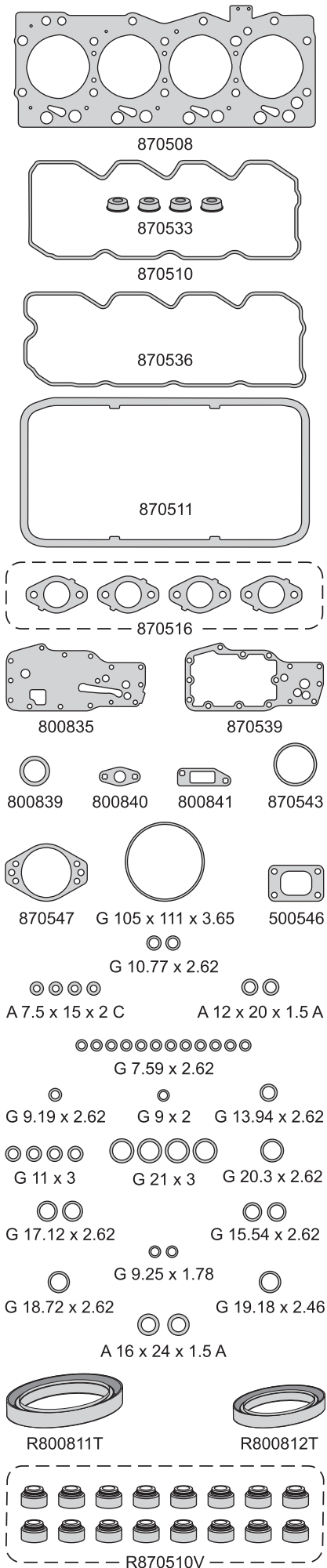

CUMMINS

CUMMINS



Motor/Engine	Cm³	HP	Ø
ISCe 6 24V	8270	315	114

Cummins: Serie C 1832/2632 2003/...
 Ford: 2632E/2932E/4432E/4532E/5032E
 VW: 17220/17300/17310/18310/19320/26320
 17250E/19320E/24250E
 Bus 17260EOT/18320EOT



DIESEL

CUMMINS

Nº OE	Descripción/Description	Mat.	Ref.
	Jgo. de juntas para motor	●	870600-R
	Junta tapa cilindros Ø 123.5 ±1.80		870607
	Jgo. de tornillos para tapa de cilindros	NFT 1	B870200
	Junta tapa válvulas	GS 1	870610
3914017	Junta para cárter	NB 1	870211
3944293	Placa distribución	NFT 1	870613
	Jgo. múltiple escape (6)	AC 1	870615
	Salida de escape	FCH 1	870618
3911941	Turbo	NB 1	870220
3992092	Base filtro	NB 1	870622
4928538	Bomba combustible	NFT 1	870628
	Junta acople	NH 1	870629
3937706	Llenado aceite	GS 1	870232
3914301	Porta retén trasero	NB 1	870233
	Junta tapa válvulas	GS 1	870633
3918174	Enfriador aceite a block	NFT 1	870234
4902952	Bomba combustible	NB 1	870634
3918332	Placa separador enfriador aceite	NFT 1	870235
	Junta aceite turbo	NB 1	870635
3940245	Junta	NFT 1	870638
3914303	Inspección distribución	NFT 1	870239
	Junta	NFT 1	870639
	Junta turbo	AC 1	870063
3906659	Arandela inyector A 7 x 15 x 1.5 C	CU 6	
3920773	Arandela A 18 x 24 x 1.5 C	CU 2	
	Arandela A 11 x 18 x 1.5 A	AL 23	
	Arandela A 14 x 20 x 1.5 A	AL 7	
	Arandela A 12 x 18 x 1.5 A	AL 15	
	O´ring G 21 x 3	GS 6	
	O´ring G 10.77 x 2.62	GS 6	
	O´ring G 28.24 x 2.62	GS 1	
	O´ring G 11 x 2.5 S	S 3	
4010519	O´ring G 11 x 2.5	GS 4	
	O´ring G 9 x 2.5	GS 2	
	O´ring G 18.72 x 2.62	GS 4	
3910824	O´ring G 9.25 x 1.78	GS 1	
	O´ring G 12.42 x 1.78	GS 1	
	O´ring G 16 x 2	GS 1	
3073966	O´ring G 47 x 4	GS 2	
	O´ring G 59.99 x 2.62	GS 1	
	O´ring G 82.22 x 2.62	GS 1	
4010643	O´ring G 16 x 2.5	GS 2	
3201562	O´ring G 22 x 3	GS 1	
	O´ring G 11 x 2.5	GS 4	
3930911	O´ring G 20.35 x 1.78	GS 1	
	O´ring G 21.82 x 3.53	GS 1	
3902089	O´ring G 98.02 x 3.53	GS 6	
	O´ring G 107.54 x 3.53	GS 6	
	Kit de retenes completo		R870200
3927642	Jgo. retén válvulas (12)	V 1	R870210V
3909410	Retén bancada 130 x 150 x 12/13	VF 1	R870011VF
3908139	Retén distribución 75 x 93 x 9/10	V 1	R870212V

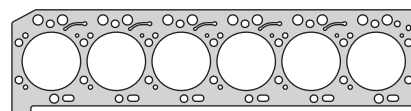

870607

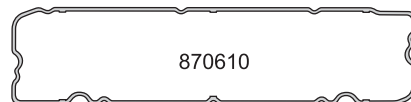

870610

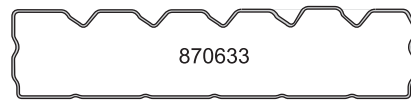

870633

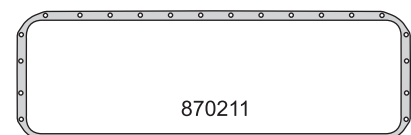

870211

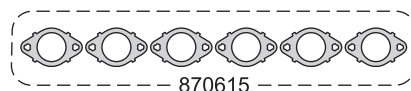

870615

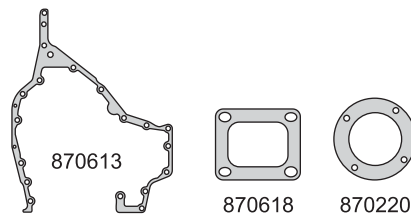

870613

870618

870220

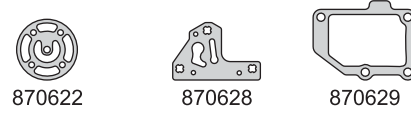

870622

870628

870629

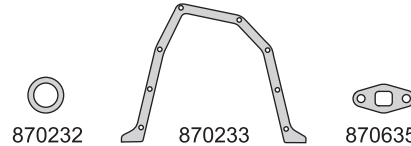

870232

870233

870635

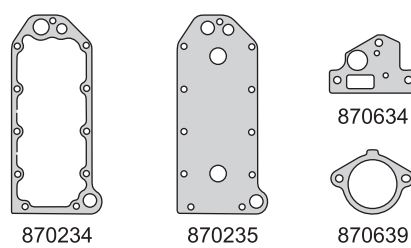

870234

870235

870634

870639

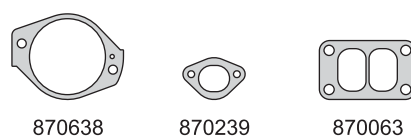

870638

870239

870063



A 7 x 15 x 1.5 C



A 12 x 18 x 1.5 A



R870011VF

R870212V

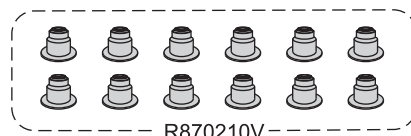

R870210V

DEUTZ



Motor/Engine	Cm³	HP	Ø
F 2L 514	2660	56	110

Deutz: A40 - Tractor



DIESEL

Nº OE	Descripción/Description	Mat.	Ref.
	Jgo. de juntas para motor		650000
	Jgo. jtas. reparación cabeza cilindros		650095
0858	Junta tapa válvulas	CG 1 2	650010
1540	Junta para cárter	CB 2	650011
8094023	Tapa distribución	CB 1	650012
8094022	Tapa trasera distribución	CB 1	650013
2215	Múltiple escape	FCH 2 4	650015
8094036	Filtro aceite	NB 1	650027
13358	Acople filtro combustible	NB 1	650028
809403709	Base bomba inyectora	CB 1	650029
8094031	Anillo deflector	CB 1	650030
8094032	Deflector	CB 1	650031
13359	Bomba alimentadora	NB 1	650032
D1520	Filtro mecánico	NB 1	650033
8094044	Tapa embutida	NB 1	650034
D1521	Arandela (4 agujeros)	NB 1	650035
D1522	Arandela (5 agujeros)	NB 1	650037
8094049	Bomba aceite	NB 3	650038
8094046	Tapa turbina	NB 1	650039
8094043	Caja reguladora	CB 3	650040
	Filtro aceite	CG 2	650041
D1529	Junta para cárter inferior	CB 1	650042
D1528	Brida	NB 1	650043
100021500	Descarga aceite tubo	GS 1 2	650044
1119	Retén guía válvulas G 16 x 4	GS 6 12	650045
1165994	Aro sello tubo retorno aceite G 12 x 3	GS 1 2	650046
8094115	Aro sello entrada radiador aceite G 25 x 4	GS 1	650047
	Aro sello radiador aceite G 28 x 4	GS 1	650048
8094116	Aro sello G 35 x 4	GS 1	650049
	Bomba vacío (todos)	NH	650055
0834	Intermedia tapa cilindros	NB 2 4	650062
0835	Intermedia tapa cilindros	CHA 1 2	650063
8094108	Aro sello o'ring G 10 x 2.5	GS 1 2	650064
	Arandela A 9 x 13 x 1 A	AL 13	650065
	Arandela A 31 x 36 x 1.5 A	AL 1	650066
	Arandela A 14 x 18 x 1 A	AL 26	650067
	Arandela A 10 x 14 x 1 A	AL 9	650068
	Arandela A 6 x 10 x 1 A	AL 8	650069
0407	Suplemento camisa cilindros 0.2 mm.	AC 1 2	650070-0.20
0407	Suplemento camisa cilindros 0.3 mm.	AC 1 2	650070-0.30
0406	Sello camisa cilindro o'ring G 110 x 4.5	GS 1 2	650072
	Arandela A 10 x 20 x 1.5 A	AL 11	650086
	Arandela A 18 x 23 x 1 A	AL 5	650087
D1523	Brida	CB 2	650088
	Retén bancada 150 x 172 x 18.3	S	R650411S

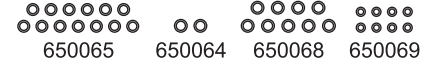
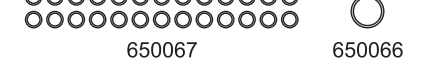
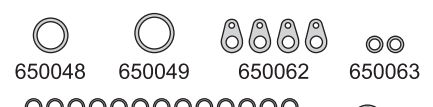
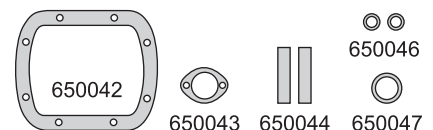
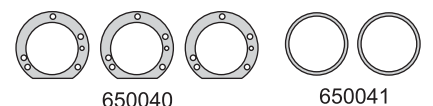
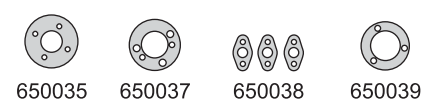
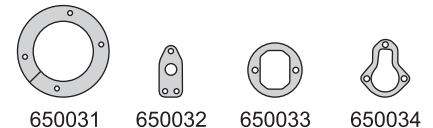
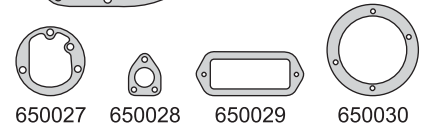
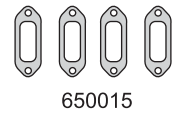
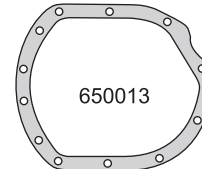
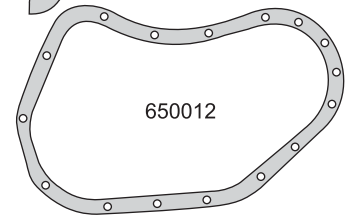
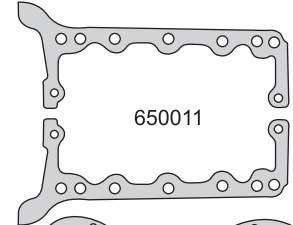
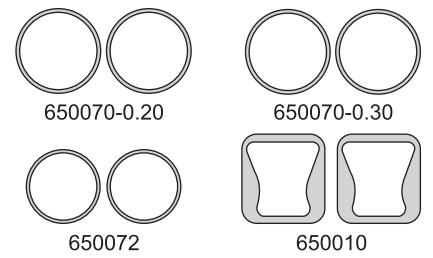

DEUTZ

DEUTZ



Motor/Engine	Cm³	HP	Ø
F 6L 913	6128	130	102

Deutz: DD1000 - DD9000 Camión
Tractor 1978/81

Ford: F7000 1978/81



DIESEL

Nº OE	Descripción/Description	Mat.	Ref.
	Jgo. de juntas para motor		650100-R
	Jgo. juntas reparación cabeza cilindro	●	650195
	Jgo. tornillos tapa cilindros (HAS17038)		B650100
3371692	Junta tapa válvulas	NB 1 6	650110
3018117	Junta para cárter	CB 1	650111
3362505	Tapa distribución	CB 1	650112
3371689	Múltiple escape	FCH 1 6	650115
2230704	Múltiple admisión	NB 1 6	650117
2231127	Lateral tubo sobrealimentación salida escape	NFT 1	650118
13358	Acople filtro combustible	NB 1	650028
3362983	Soporte filtro aceite	NB 2	650129
1216307	Arandela fijación tapa válvulas	PLAST 1 6	650130
	Base sobrealimentador	NFT 1	650131
2134209	Tubo retorno aceite al turbo	NB 1	650132
2137840	Tapa y codo múltiple admisión	NB 2	650133
3362337	Tapa trasera cigüeñal	CB 1	650134
1231000	Tapa boca llenado aceite	CG 1	650135
	Arandela A 22 x 27 x 1.5 A	AL 1	650535
1166053	Tapa boca llenado aceite	CG 1	650137
1118764	Arandela tapón cabeza cil. A 26 x 32 x 2 A	AL 2 12	650138
1166103	Arandela base bomba inyectora G 74 x 3	GS 1	650139
3372164	Bomba inyectora A 10 x 21 x 2 C	CU 6	650140
1167425	Radiador aceite	GS 1	650141
1166002	Arandela tubo presión aceite G 14 x 3	GS 1	650142
1118836	Tapa ref. aceite A 45.5 x 52 x 2	GS	650143
	Arandela A 17 x 22 x 1 A	AL 2	650243
1118675	Tapa block A 12 x 16 x 1.5 A	AL 8	650144
D076031200	Arandela term. sobrepres. A 8 x 12 x 1 C	CU 14	650145
	Arandela A 10 x 14 x 1 A	AL 1	650146
2232527	Retén guía válvulas	GS 2 12	650147/1
2232527	Retén guía válvulas	GS 2 12	650147/2
	Bomba hidráulica motor	CB 1	650148
	Junta tapa válvulas	GS	650149
	Arandela A 10 x 16 x 1 A	AL 1	650068
2230216	Anillo intermedia cilindros	AC 1 6	650170
2137256	Suplemento camisa cilindros 0.2 mm.	AC 1 6	650170-0.20
2232693	Suplemento camisa cilindros 0.3 mm.	AC 1 6	650170-0.30
	Suplemento camisa cilindros 0.5 mm.	AC	650170-0.50
	Arandela A 18 x 23 x 1 A	AL 1	650087
	Jgo. retén válvulas (12)	P 1	R650110P
	Retén bancada 115 x 140 x 16	P 1	R650111P
	Retén distribución 65 x 85 x 13	P 1	R650112P



650170



650170-0.20



650170-0.30



650110

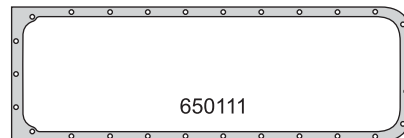

650111

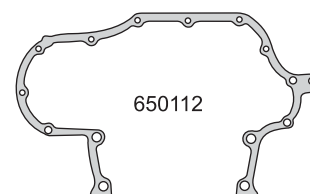

650112

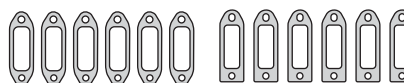

650115

650117



650118

650028

650129

650130

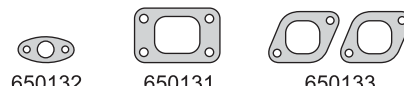

650132

650131

650133

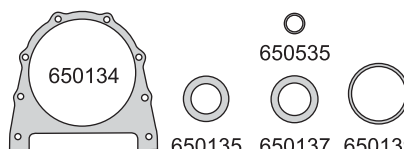

650134

650535

650135

650137

650139



650138



650140

650141

650142

650243

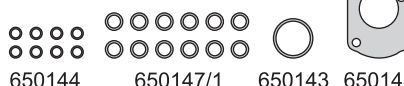

650144

650147/1

650143

650148



650147/2



650145

650146

650068

650087



R650111P



R650112P

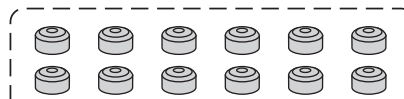

R650110P

DEUTZ

DEUTZ



Motor/Engine	Cm³	HP	Ø
AF 2L 1114	2908		115
AF 2L 2114	3167		120

Deutz: 69/75 A46 - Tractor 74/78 A65
1969/75



DIESEL

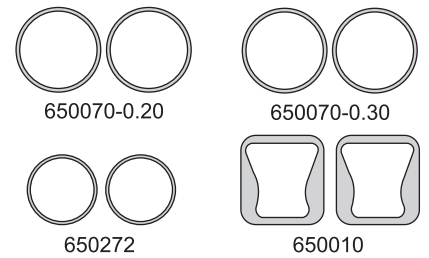

Nº OE	Descripción/Description	Mat.	Ref.
	Jgo. de juntas para motor		650200
	Jgo. jtas. reparación cabeza cilindros		650295
0858	Junta tapa válvulas	CG 1 2	650010
1540	Junta para cárter	CB 2	650011
8094023	Tapa distribución	CB 1	650012
8094022	Tapa trasera distribución	CB 1	650013
2215	Múltiple escape	FCH 2 4	650015
13358	Acople filtro combustible	NB 1	650028
809403709	Base bomba inyectora	CB 1	650029
8094031	Anillo deflector	CB 1	650030
8094032	Deflector	CB 1	650031
13359	Bomba alimentadora	NB 1	650032
D1520	Filtro mecánico	NB 1	650033
8094044	Tapa embutida	NB 1	650034
D1521	Arandela (4 agujeros)	NB 1	650035
D1522	Arandela (5 agujeros)	NB 1	650037
8094049	Bomba aceite	NB 3	650038
8094046	Tapa turbina	NB 1	650039
	Arandela A 14 x 20 x 1.5 A	AL 26	650539
8094043	Caja reguladora	CB 2	650040
	Arandela A 9 x 13 x 1 A	AL 15	650241
D1529	Junta para cárter inferior	CB 1	650042
	Arandela A 6 x 9 x 1 A	AL 2	650242
	Arandela A 17 x 22 x 1 A	AL 9	650243
100021500	Descarga aceite 1114	GS 1 2	650044
3017883	Descarga aceite 2114	GS 4	650244
1119	Retén guía válvulas G 16 x 4	GS 6 12	650045
1165994	Aro sello tubo retorno aceite G 12 x 3	GS 1 2	650046
100172700	Intermedia tapa cilindros (corta)	CHA 1 2	650262
0835	Intermedia tapa cilindros	CHA 1 2	650063
100172800	Intermedia tapa cilindros (larga)	CHA 1 2	650263
8094108	Aro sello G 10 x 2.5	GS 1 2	650064
	Arandela A 31 x 36 x 1.5 A	AL 1	650066
	Arandela A 10 x 14 x 1 A	AL 9	650068
	Arandela A 6 x 10 x 1 A	AL 4	650069
0407	Suplemento camisa cilindros 0.2 mm.	AC 1 2	650070-0.20
0407	Suplemento camisa cilindros 0.3 mm.	AC 1 2	650070-0.30
810292702	Sello camisa cilindros G 115 x 2	GS 1 2	650272
	Arandela A 18 x 23 x 1 A	AL 9	650087
D1523	Brida	CB 2	650088
	Retén bancada 150 x 172 x 18.30	S	R650411S
	Retén distribución 110 x 140 x 16	P	R650212P

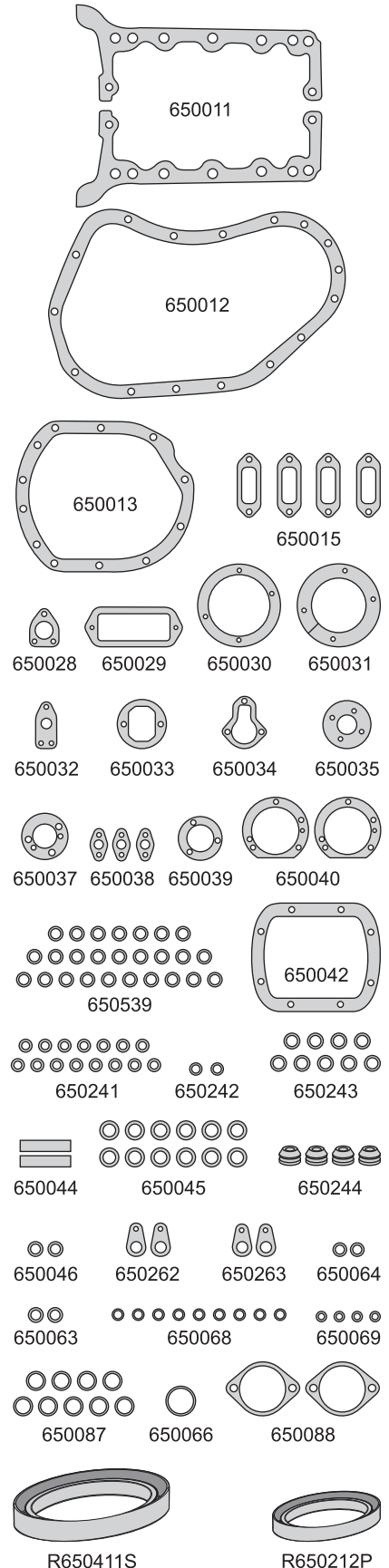

DEUTZ

DEUTZ



Motor/Engine **F 3L 514** Cm³ **3990** HP **50** Ø **110**

Deutz: 514 - Tractor A55 1959/69

DIESEL

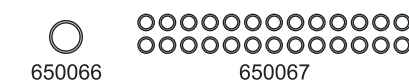
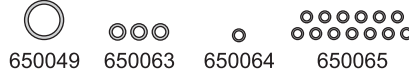
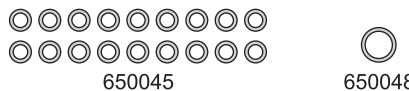
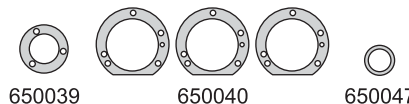
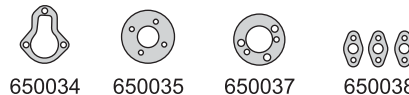
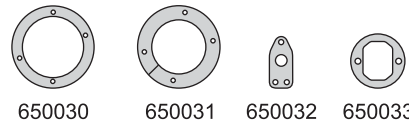
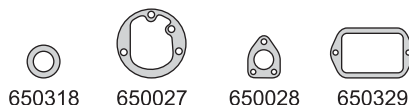
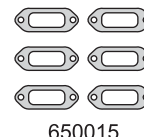
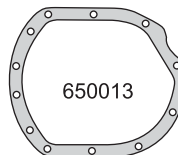
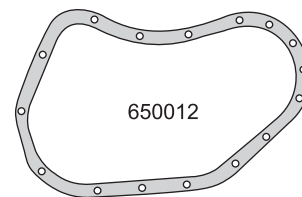
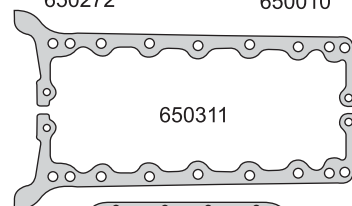

DEUTZ

Nº OE	Descripción/Description	Mat.	Ref.
	Jgo. de juntas para motor		650300
	Jgo. jtas. reparación cabeza cilindros		650395
0858	Junta tapa válvulas	CG 1 3	650010
8094027	Junta para cárter	CB 2	650311
8094023	Tapa distribución	CB 1	650012
8094022	Tapa trasera distribución	CB 1	650013
2215	Múltiple escape	FCH 2 6	650015
	Salida de escape	NFT 1	650318
8094036	Filtro aceite	NB 1	650027
13358	Acople filtro combustible	NB 1	650028
8094037	Base bomba inyectora	CB 1	650329
8094031	Anillo deflector	CB 1	650030
8094032	Deflector	CB 1	650031
13359	Bomba alimentadora	NB 1	650032
D1520	Filtro mecánico	NB 1	650033
8094044	Tapa embutida	NB 1	650034
D1521	Arandela (4 agujeros)	NB 1	650035
8094030	Junta tapa válvulas lateral	CB 1	650336
D1522	Arandela (5 agujeros)	NB 1	650037
8094049	Bomba aceite	NB 3	650038
8094046	Tapa turbina	NB 1	650039
8094043	Caja reguladora	CB 3	650040
	Filtro aceite	CG 2	650041
D1528	Brida	NB 1	650043
100021500	Descarga aceite	GS 3	650044
3017883	Descargo aceite	GS 2	650244
1119	Retén guía válvulas G 16 x 4	GS 6 18	650045
1165994	Aro sello tubo retorno aceite G 12 x 3	GS 1 3	650046
8094115	Aro sello entrada radiador aceite G 25 x 4	GS 1	650047
	Aro sello radiador aceite G 28 x 4	GS 1	650048
8094116	Aro sello G 35 x 4	GS 1	650049
	Bancada 150 x 170 x 10	SNA 1	650358
0834	Intermedia tapa cilindros	NB 6	650062
100172700	Intermedia tapa cilindros (corta)	CHA 1	650262
0835	Intermedia tapa cilindros	CHA 1 3	650063
100172800	Intermedia tapa cilindros (larga)	CHA 1	650263
8094108	Aro sello G 10 x 2.5	GS 1 3	650064
	Arandela A 9 x 13 x 1 A	AL 13	650065
	Arandela A 31 x 36 x 1.5 A	AL 1	650066
	Arandela A 14 x 18 x 1 A	AL 26	650067
	Arandela A 6 x 10 x 1 A	AL 8	650069
0407	Suplemento camisa cilindros 0.2 mm.	AC 1 3	650070-0.20
0407	Suplemento camisa cilindros 0.3 mm.	AC 1 3	650070-0.30
810292702	Sello camisa cilindros G 110 x 4.5	GS	650072
	Sello camisa cilindros G 115 x 2	GS 1 3	650272
	Arandela A 10 x 20 x 1.5 A	AL 1	650086
D1523	Arandela A 18 x 23 x 1 A	AL 5	650087
	Brida	CB 2	650088
	Retén bancada 150 x 172 x 18.30	GS	R650411S

DEUTZ



Motor/Engine	Cm³	HP	Ø
F 4L 514	5320	65	110

Deutz: 514 - Tractor 470 1959/69



DIESEL

Nº OE	Descripción/Description	Mat.	Ref.
	Jgo. de juntas para motor		650400
	Jgo. jtas. reparación cabeza cilindros		650095
0858	Junta tapa válvulas	CG 1 4	650010
1529	Junta para cárter	GS 1	650411
8094007	Junta tapa distribución delantera	CB 1	650412
8094008	Tapa trasera distribución	CB 1	650413
2215	Múltiple escape	FCH 2 8	650015
	Salida de escape	NFT 1	650318
1042404	Filtro aceite	NB 2	650427
13358	Acople filtro combustible	NB 1	650028
22DIN71511	Filtro aceite	NB 1	650429
8094014	Tapa leva	NB 1	650430
3469892	Soporte filtro aceite	NB 1	650532
D1521	Arandela (4 agujeros)	NB 1	650035
8094049	Bomba aceite	NB 3	650038
8094046	Tapa turbina	NB 1	650039
	Filtro aceite	CG 2	650041
100021500	Descarga aceite	GS 1 4	650044
1119	Retén guía válvulas G 16 x 4	GS 6 24	650045
1165994	Aro sello tubo retorno aceite G 12 x 3	GS 1 4	650046
8094115	Aro sello entrada radiador aceite G 25 x 4	GS 1	650047
	Aro sello radiador aceite G 28 x 4	GS 1	650048
8094116	Aro sello G 35 x 4	GS 1	650049
	Bancada 150 x 170 x 10	SNA 1	650358
0834	Intermedia tapa cilindros	NB 2 8	650062
0835	Intermedia tapa cilindros	CHA 1 4	650063
8094108	Aro sello G 10 x 2.5	GS 1 4	650064
	Arandela A 9 x 13 x 1 A	AL 13	650065
	Arandela A 31 x 36 x 1.5 A	AL 1	650066
	Arandela A 14 x 18 x 1 A	AL 26	650067
	Arandela A 10 x 14 x 1 A	AL 9	650068
	Arandela A 6 x 10 x 1 A	AL 8	650069
0407	Suplemento camisa cilindros 0.2 mm.	AC 1 4	650070-0.20
0407	Suplemento camisa cilindros 0.3 mm.	AC 1 4	650070-0.30
0406	Sello camisa cilindros G 110 x 4.5	GS 1 4	650072
	Arandela A 10 x 20 x 1.5 A	AL 11	650086
	Arandela A 18 x 23 x 1 A	AL 5	650087
	Retén bancada 150 x 172 x 18.30	S	R650411S

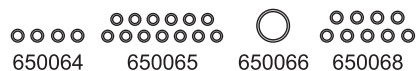
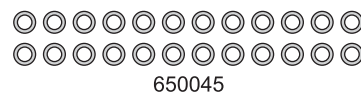
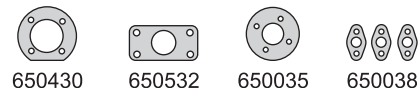
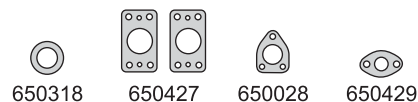
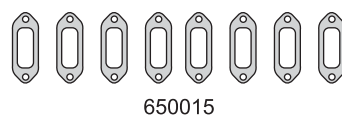
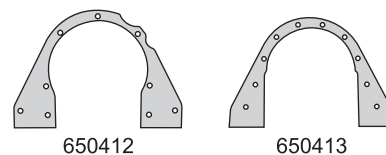
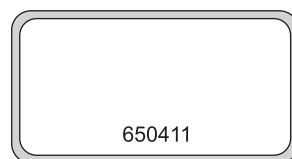
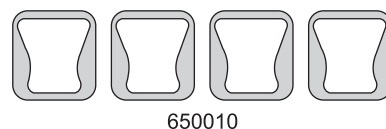
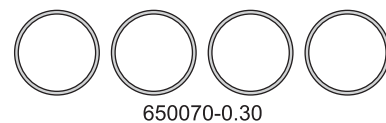

DEUTZ

DEUTZ



Motor/Engine **F 6L 514** Cm³ **7980** HP **110** Ø

Deutz: 514 A110 - Tractor 1959/69

DIESEL



Nº OE	Descripción/Description	Mat.	Ref.
	Jgo. de juntas para motor		650500
	Jgo. jtas. reparación cabeza cilindros		650095
0858	Junta tapa válvulas	CG 1 6	650010
10611070	Junta para cárter	GS 1 1	650511
8094007	Tapa distribución delantera	CB 1 1	650412
8094008	Tapa trasera distribución	CB 1 1	650413
2215	Múltiple escape	FCH 2 12	650015
	Salida de escape	NFT 1 1	650318
1042404	Filtro aceite	NB 2 2	650427
13358	Acople filtro combustible	NB 1 1	650028
22DIN71511	Filtro aceite	NB 1 1	650429
1061106	Tapa distribución	CG 1 1	650529
8094031	Anillo deflector	CB 1 1	650030
	Base filtro	CB 1 1	650531
3469892	SopORTE filtro aceite	NB 1 1	650532
	Filtro aceite	CB 1 1	650533
26DIN71511	Caño radiador aceite	NB 1 1	650534
	Arandela A 22 x 27 x 1.5 A	AL 3 3	650535
	Arandela A 26 x 32 x 2 A	AL 1 1	650537
	Arandela A 36 x 42 x 1.5 A	AL 2 2	650538
	Arandela A 14 x 20 x 1.5 A	AL 24 24	650539
	Aro sello G 320 x 8 turbina	GS 1 1	650540
	Filtro aceite	CG 2 2	650041
100021500	Descarga aceite	GS 1 6	650044
1119	Retén guía válvulas G 16 x 4	GS 6 36	650045
1165994	Aro sello tubería retorno aceite G 12 x 3	GS 1 6	650046
8094115	Aro sello entrada radiador aceite G 25 x 4	GS 1 1	650047
	Aro sello radiador aceite G 28 x 4	GS 1 1	650048
8094116	Aro sello G 35 x 4	GS 1 1	650049
	Bancada cigüeñal 120 x 140 x 10	SNA 1 1	650558
	Bancada cigüeñal del. 70 x 90 x 10	SNA 1 1	650858
0834	Intermedia tapa cilindros	NB 2 12	650062
0835	Intermedia tapa cilindros	CHA 1 6	650063
8094108	Aro sello G 10 x 2.5	GS 1 6	650064
	Arandela A 9 x 13 x 1 A	AL 20 20	650065
	Arandela A 31 x 36 x 1.5 A	AL 1 1	650066
	Arandela A 10 x 14 x 1 A	AL 10 10	650068
	Arandela A 6 x 10 x 1 A	AL 6 6	650069
0407	Suplemento camisa cilindros 0.2 mm.	AC 1 6	650070-0.20
0407	Suplemento camisa cilindros 0.3 mm.	AC 1 6	650070-0.30
0406	Sello camisa cilindros G 110 x 4.5	GS 1 6	650072
	Arandela A 18 x 23 x 1 A	AL 6 6	650087
	Retén bancada 150 x 172 x 18.30	S	R650411S

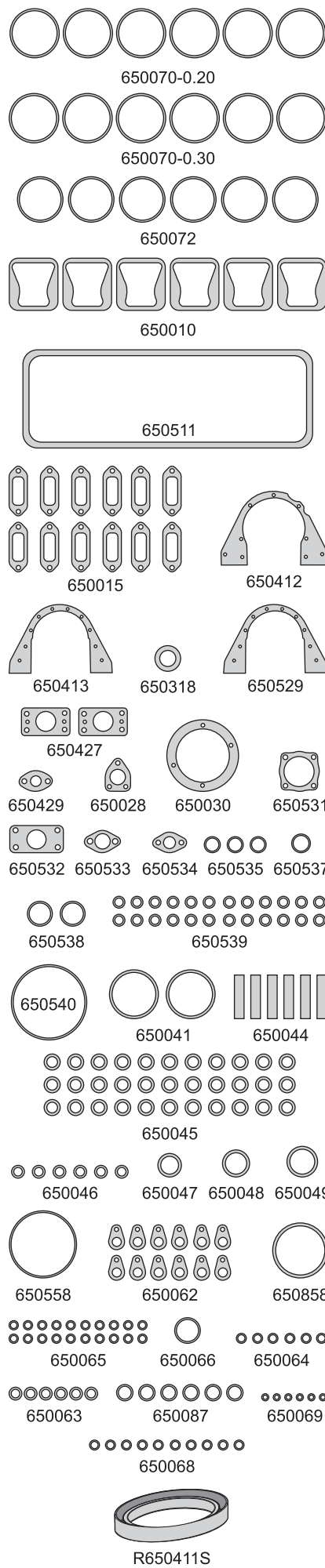

DEUTZ

DEUTZ



Motor/Engine	Cm³	HP	Ø
AF 3L 1114	4363		115
AF 3L 2114	4750		120

Deutz: 1114/ 2114 - Tractor A65 1969/78



DIESEL

Nº OE	Descripción/Description	Mat.	1	3	Ref.
	Jgo. de juntas para motor		●	●	650600
	Jgo. jtas. reparación cabeza cil. 1114		●		650295
	Jgo. jtas. reparación cabeza cil. 2114			●	650395
0858	Junta tapa válvulas	CG	1	3	650010
8094027	Junta para cárter	CB		2	650311
8094023	Tapa distribución	CB		1	650012
8094022	Tapa trasera distribución	CB		1	650013
2215	Múltiple escape	FCH	2	6	650015
	Salida de escape	NFT		1	650318
13358	Acople filtro combustible	NB		1	650028
809403709	Base bomba inyectora	CB		1	650029
8094037	Base bomba inyectora	CB		1	650329
8094031	Anillo deflector	CB		1	650030
8094032	Deflector	CB		1	650031
13359	Bomba alimentadora	NB		1	650032
D1520	Filtro mecánico	NB		1	650033
8094044	Tapa embutida	NB		1	650034
D1521	Arandela 4 agujeros	NB		1	650035
8094030	Junta tapa válvulas lateral	CB		1	650336
8094049	Bomba aceite	NB		3	650038
8094046	Tapa turbina	NB		1	650039
	Arandela A 14 x 20 x 1.5 A	AL		28	650539
8094043	Caja reguladora	CB		2	650040
	Arandela A 8 x 13 x 1 A	AL		19	650241
	Arandela A 17 x 22 x 1 A	AL		11	650243
100021500	Descarga aceite 1114	GS	1	3	650044
3017883	Descarga aceite 2114	GS		6	650244
1119	Retén guía válvulas G 16 x 4	GS	6	18	650045
1165994	Aro sello tubo retorno aceite G 12 x 3	GS	1	3	650046
	Bancada cigüeñal 150 x 170 x 10	SNA		1	650358
100172700	Intermedia tapa cilindros (corta)	CHA	1	3	650262
0835	Intermedia tapa cilindros	CHA	1	3	650063
100172800	Intermedia tapa cilindros (larga)	CHA	1	3	650263
8094108	Aro sello G 10 x 2.5	GS	1	3	650064
	Arandela A 31 x 36 x 1.5 A	AL		1	650066
	Arandela A 10 x 14 x 1 A	AL		9	650068
	Arandela A 6 x 10 x 1 A	AL		3	650069
0407	Suplemento camisa cilindros 0.2 mm.	AC	1	3	650070-0.20
0407	Suplemento camisa cilindros 0.3 mm.	AC	1	3	650070-0.30
810292702	Sello camisa cilindros G 115 x 2	GS	1	3	650272
	Arandela A 18 x 23 x 1 A	AL		9	650087
	Retén bancada 150 x 172 x 18.30	S			R650411S
	Retén distribución 110 x 140 x 16	P			R650212P

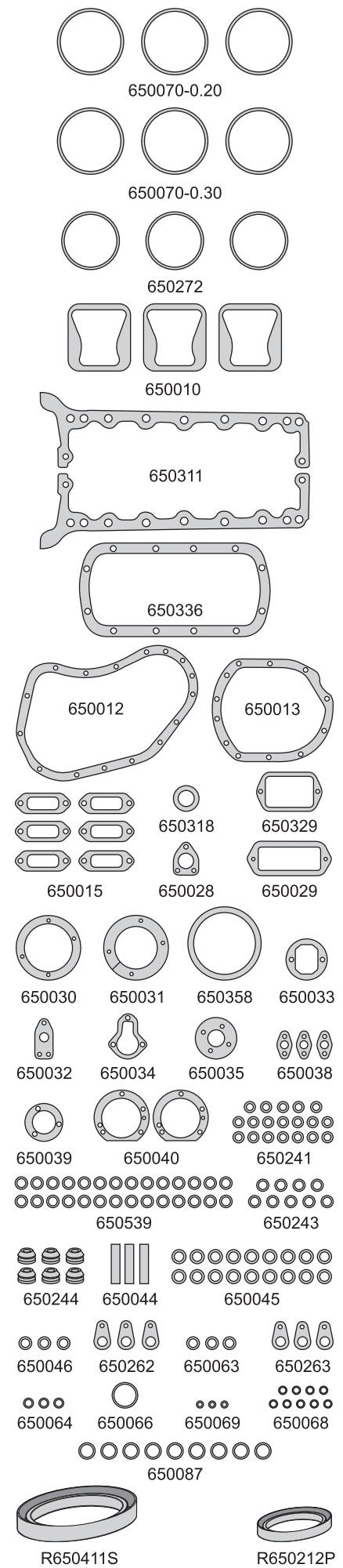

DEUTZ

DEUTZ



Motor/Engine **Cm³** **HP** **Ø**

AF 4L 1114 **5817** **115**
 AF 4L 2114 **6333** **120**

Deutz: 1114/ 2114 - Tractor A85 1969/78



DIESEL

Nº OE	Descripción/Description	Mat.			Ref.
	Jgo. de juntas para motor				650700
	Jgo. jtas. reparación cabeza cil. 1114		●		650295
	Jgo. jtas. reparación cabeza cil. 2114				650395
0858	Junta tapa válvulas	CG	1	4	650010
1529	Junta para cárter	GS		1	650411
8094007	Tapa delantera distribución	CB		1	650412
8094008	Tapa trasera distribución	CB		1	650413
2215	Múltiple escape	FCH	2	8	650015
	Salida de escape	NFT		1	650318
1042404	Filtro aceite	NB		2	650427
13358	Acople filtro combustible	NB		1	650028
22DIN71511	Filtro aceite	NB		2	650429
8094014	Tapa leva	NB		1	650430
3469892	Soporte filtro aceite	NB		1	650532
26DIN71511	Caño radiador aceite	NB		2	650534
	Arandela A 22 x 27 x 1.5 A	AL		1	650535
	Arandela A 26 x 32 x 2 A	AL		1	650537
8094049	Bomba aceite	NB		2	650038
	Arandela A 36 x 42 x 1.5 A	AL		2	650538
	Arandela A 14 x 20 x 1.5 A	AL		20	650539
	Aro sello G 320 x 8	GS		1	650540
	Arandela A 8 x 13 x 1 A	AL		16	650241
	Arandela A 6 x 9 x 1 A	AL		2	650242
100021500	Descarga aceite 1114	GS	1	4	650044
3017883	Descarga aceite 2114	GS		8	650244
1119	Retén guía válvulas G 16 x 4	GS	6	24	650045
1165994	Aro sello tub. retorno aceite G 12 x 3	GS	1	4	650046
8094115	Aro sello entrada radiador aceite G 25 x 4	GS		4	650047
	Aro sello radiador aceite G 28 x 4	GS		1	650048
8094116	Aro sello G 35 x 4	GS		1	650049
	Bancada cigüeñal 150 x 170 x 10	SNA		1	650358
100172700	Intermedia tapa cilindros (corta)	CHA	1	4	650262
0835	Intermedia tapa cilindros	CHA	1	4	650063
100172800	Intermedia tapa cilindros (larga)	CHA	1	4	650263
8094108	Aro sello G 10 x 2.5	GS	1	4	650064
	Arandela A 31 x 36 x 1.5 A	AL		1	650066
	Arandela A 10 x 14 x 1 A	AL		10	650068
	Arandela A 6 x 10 x 1 A	AL		1	650069
0407	Suplemento camisa cilindros 0.2 mm.	AC	1	4	650070-0.20
0407	Suplemento camisa cilindros 0.3 mm.	AC	1	4	650070-0.30
810292702	Sello camisa cilindros G 115 x 2	GS	1	4	650272
	Arandela A 18 x 23 x 1 A	AL		13	650087
	Retén bancada 150 x 172 x 18.30	S			R650411S
	Retén distribución 110 x 140 x 16	P			R650212P

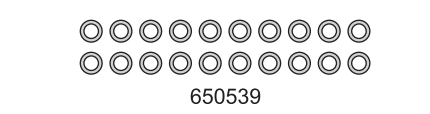
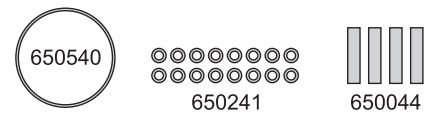
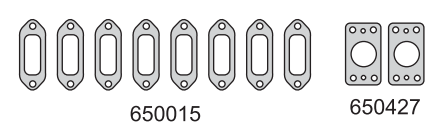
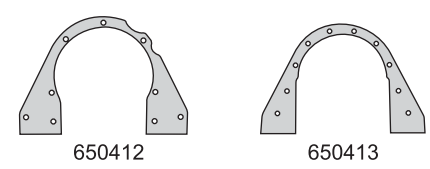
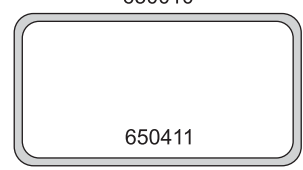
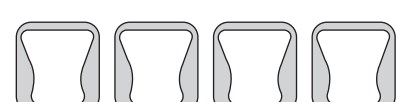
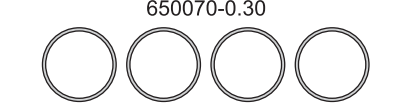

DEUTZ

DEUTZ



Motor/Engine	Cm³	HP	Ø
AF 6L 1114	8725		115
BF 6L 2114	9500		120

Deutz: 1114/ 2114 - Turbo - Bus
Tractor - A130 - A144 1969/78



DIESEL

Nº OE	Descripción/Description	Mat.	Ref.
	Jgo. de juntas para motor		650800
	Jgo. jtas. reparación cabeza cil. 1114		650295
	Jgo. jtas. reparación cabeza cil. 2114		650395
0858	Junta tapa válvulas	CG 1 6	650010
10611070	Junta para cárter	GS 1	650511
8094007	Tapa distribución delantera	CB 1	650412
8094008	Tapa trasera distribución	CB 1	650413
2215	Múltiple escape	FCH 2 12	650015
	Salida de escape	NFT 1	650318
1042404	Filtro aceite	NB 2	650427
13358	Acople filtro combustible	NB 1	650028
22DIN71511	Filtro aceite	NB 1	650429
1061106	Tapa distribución	CG 1	650529
8094014	Tapa leva	NB 1	650430
3469892	Soporte filtro aceite	NB 1	650532
	Filtro aceite	CB 1	650533
26DIN71511	Caño radiador aceite	NB 1	650534
	Arandela A 22 x 27 x 1 A	AL 1	650535
	Arandela A 26 x 32 x 2 A	AL 1	650537
	Arandela A 36 x 42 x 1.5 A	AL 2	650538
	Arandela A 14 x 20 x 1.5 A	AL 20	650539
	Aro sello G 320 x 8	GS 1	650540
	Filtro aceite	CG 2	650041
	Arandela A 8 x 13 x 1 A	AL 20	650241
	Arandela A 6 x 9 x 1 A	AL 4	650242
100021500	Descarga aceite 1114	GS 1 6	650044
3017883	Descarga aceite 2114	GS 12	650244
1119	Retén guía válvulas G 16 x 4	GS 6 36	650045
1165994	Aro sello tubo retorno aceite G 12 x 3	GS 1 6	650046
8094115	Aro sello entrada radiador aceite G 25 x 4	GS 4	650047
8094116	Aro sello G 35 x 4	GS 1	650049
	Bancada cigüeñal 120 x 140 x 10	SNA 1	650558
	Bancada cigüeñal delantera 70 x 90 x 10	SNA 1	650858
100172700	Intermedia tapa cilindros (corta)	CHA 1 6	650262
0835	Intermedia tapa cilindros	CHA 1 6	650063
100172800	Intermedia tapa cilindros (larga)	CHA 1 6	650263
8094108	Aro sello G 10 x 2.5	GS 1 6	650064
	Arandela A 31 x 36 x 1.5 A	AL 1	650066
	Arandela A 10 x 14 x 1 A	AL 15	650068
	Arandela A 6 x 10 x 1 A	AL 1	650069
0407	Suplemento camisa cilindros 0.2 mm.	AC 1 6	650070-0.20
0407	Suplemento camisa cilindros 0.3 mm.	AC 1 6	650070-0.30
810292702	Sello camisa cilindros G 115 x 2	GS 1 6	650272
	Arandela A 18 x 23 x 1 A	AL 12	650087
	Retén bancada 150 x 172 x 18.30	S	R650411S
	Retén distribución 110 x 140 x 16	P	R650212P

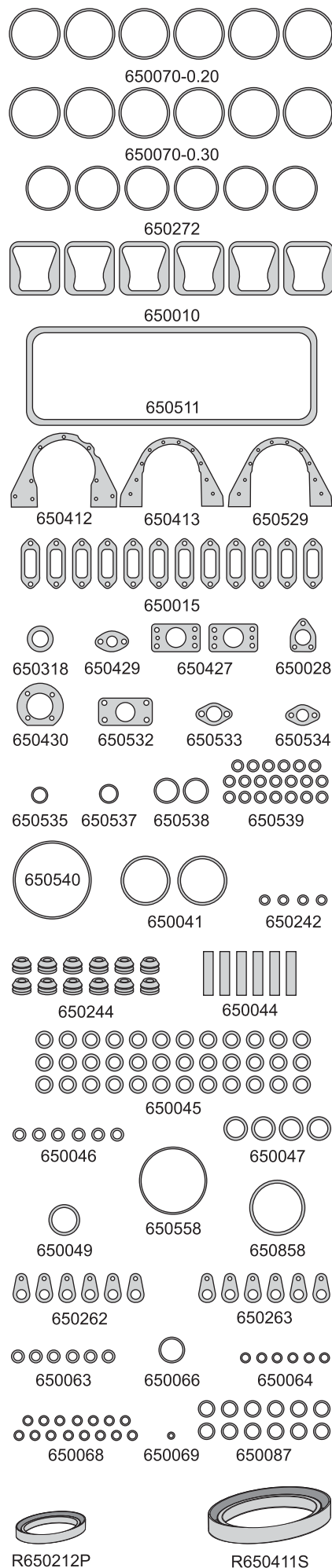

DEUTZ

DEUTZ



Motor/Engine **Cm³** **HP** **Ø**

F 8L 413 V8 **11309** **120**

Deutz: 200 D16 - 200 D19 - 200 D2M
200 RS - 210 EV 120 - 5020 1969/77

DIESEL



DEUTZ

Nº OE	Descripción/Description	Mat.	Ref.
	Jgo. de juntas para motor		650900-R
2402812	Junta tapa válvulas	CG 8	650910
2403211	Junta para cárter	NB 1	650911
3361393	Tapa delantera distribución	CB 1	650912
3361324	Tapa trasera distribución	CB 1	650913
3362170	Múltiple escape	AC 8	650915
2407259	Múltiple admisión	AC 8	650917
13358	Acople filtro combustible	NB 1	650028
2192080	Tapa trasera árbol levas	CB 1	650929
1216307	Arandela fijación tapa válvulas	PLAST 8	650130
3371139	Boca ventilación cárter	CB 1	650931
1171077	Aro sello porta balancines	GS 16	650932
2144131	Tapón tubo protector balancines	GS 16	650933
1169597	Aro sello cañería retorno bomba inyectora	GS 1	650934
	Arandela A 22 x 27 x 1.5 A	AL 1	650535
2403940	Retén guía válvulas	GS 16	650935
	Arandela A 26.5 x 31.5 x 2 A	AL 1	650537
3361627	Caño botadores	16	650937
	Arandela A 36 x 42 x 1.5 A	AL 9	650538
3361630	Descarga aceite a block	GS 8	650938
3361629	Descarga aceite a block	GS 8	650939
3361272	Caño botadores	16	650940
	Arandela A 8 x 13 x 1 A	AL 2	650241
1170540	Aro sello porta tobera bomba inyectora	10	650941
3361699	Base radiador aceite	GS 1	650942
3361698	Base filtro aceite	GS 1	650943
2407947	Aro sello tapa turbo ventilador	GS 1	650944
	Arandela A 16 x 20 x 1 A	AL 1	650945
	Arandela A 9 x 13 x 1 A	AL 16	650065
	Arandela A 31 x 36 x 1.5 A	AL 1	650066
	Arandela A 14 x 18 x 1 A	AL 18	650067
	Arandela A 10 x 14 x 1 A	AL 19	650068
2403141	Suplemento camisa cilindro 0.2 mm.	AC 8	650970-0.20
2403142	Suplemento camisa cilindro 0.3 mm.	AC 8	650970-0.30
2402639	Aro sello camisa cilindros	GS 8	650972
	Arandela A 18 x 23 x 1 A	AL 2	650087
	Retén bancada 150 x 172 x 18.30	S 1	R650411S
	Retén distribución 100 x 120 x 15	P 1	R650912P

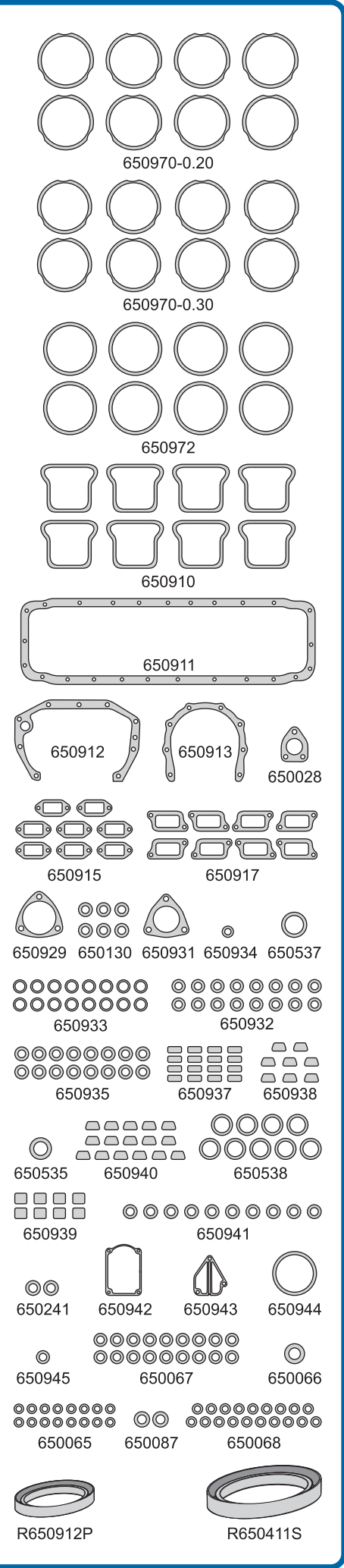

DEUTZ



Motor/Engine	Cm³	HP	Ø
F 8L 413 F V8	11309	205	125
DIESEL			

Deutz: Estacionarios 0302 6472 AY 0148-00
 0301 7177 UY 0147-00
 Vehicular Omnibus - Camiones
 0302 6545 AY 0148-00
 0301 7177 UY 0147-00



Nº OE	Descripción/Description	Mat.	Ref.
2911536	Jgo. de juntas para motor		651000-R
	Jgo. reparación cabeza cilindros		651095
2406592	Jgo. de tornillos para tapa de cilindros		B650900
2144838	Junta tapa válvulas	CG 1 8	651010
2131577	Junta para cárter	NB 1	650911
3361393	Junta frente motor	NB 1	650912
3361324	Junta porta retén trasero	NB 1	650913
41419791	Múltiple escape	AC 1 8	651015
4141486	Múltiple admisión	AC 1 8	650917
3029697	Salida de escape	NFT 2	650318
2410725	Junta carcasa bomba de aceite	NB 1	650927
3018849	Junta bomba de alimentación	NB 1	650028
2192080	Junta trasera árbol de levas	CB 1	650929
2141519	Anillo fijación tapa de válvulas A 8 x 15.5	PLAST 1 8	650130
3371139	Junta boca base llenado de aceite	CB 1	650931
2144877	Junta caja balancines	NB 1 8	651036
2423671	Anillo hermetización	PLAST 1 8	651037
1120804	Junta tubería de aceite	NB 1	651038
1216293	Junta tapa llenado de aceite G 60 x 38 x 2	GS 1	450041
3361699	Junta base radiador aceite	GS 1	650942
2417871-1	Junta base filtro aceite	GS 1	651043
3370133	Rodillo amortiguador turbo ventilador	GS 4	650964
3361338	Anillo tubo balancín G 16 x 20 x 12	GS 1	650965
1120804	Junta cañería aceite	CB 1	651066
1163871	O´ring camisa cilindros G 140 x 3	GS 1 8	651070
4183249	Jgo. suplemento camisa cilindros (0.50) (8)	AC 1 1	651070-0.50
4183250	Jgo. suplemento camisa cilindros (0.70) (8)	AC 1 1	651070-0.70
4183251	Jgo. suplemento camisa cilindros (1.00) (8)	AC 1 1	651070-1.00
1171939	O´ring G 18 x 4	GS 4 32	
	O´ring G 20 x 4	GS 1 8	
1171077	O´ring G 10 x 4	GS 2 16	
1165996	O´ring G 12 x 3	GS 1	
1174733	O´ring G 8 x 3	GS 1 8	
1166075	O´ring G 45 x 4.5	GS 1	
1165975	O´ring G 5 x 2	GS 1	
1166045	O´ring G 30 x 4	GS 1	
1167374	O´ring G 25 x 2	GS 4	
1166089	O´ring G 60 x 4	GS 1	
1161249	O´ring G 170 x 6	GS 1	
1167379	O´ring G 40 x 3	GS 1	
1164294	O´ring G 120 x 4	GS 1	
1161019	O´ring G 25 x 4	GS 2	
2403867	Arandela pico inyector A 10 x 21 x 2 C	CU 1 8	
1107101	Arandela A 8 x 11.5 x 1 C	CU 4 32	
1118654	Arandela A 8 x 14 x 1.5 C	CU 15	
1118784	Arandela A 30 x 36 x 1.5 C	CU 3	
2403108	Arandela A 14.5 x 18 x 1.25 C	CU 18	
1118664	Arandela A 10 x 14 x 1.25 C	CU 20	
1118693	Arandela A 14 x 20 x 1.25 C	CU 6	
1118718	Arandela A 18 x 24 x 1.25 C	CU 1	
3370359	Arandela A 6 x 12 x 1 C	CU 20	
1107095	Arandela A 7 x 14 x 1 C	CU 4	
2133325	Arandela A 22 x 27 x 1.5 A	AL 3	

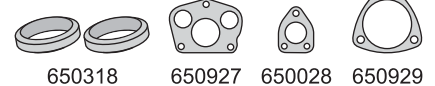
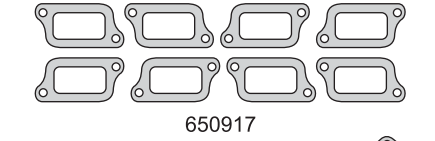
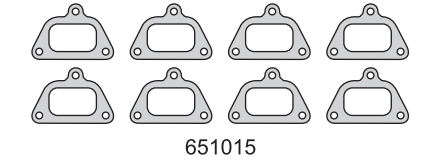
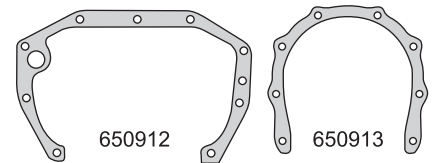
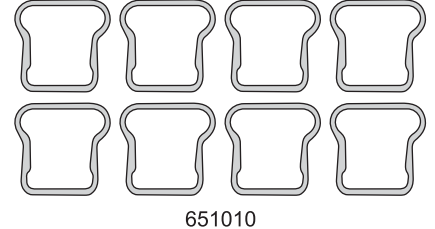
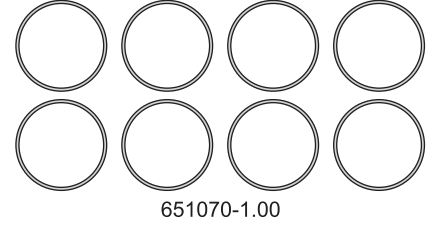
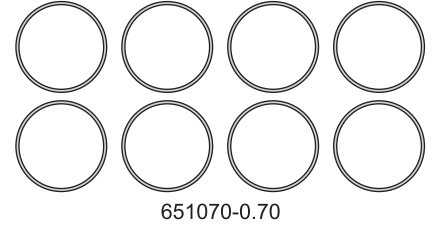
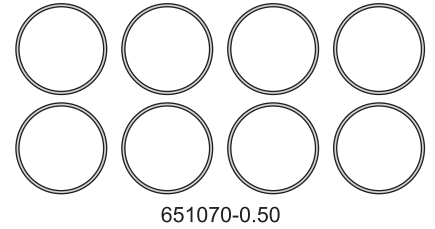
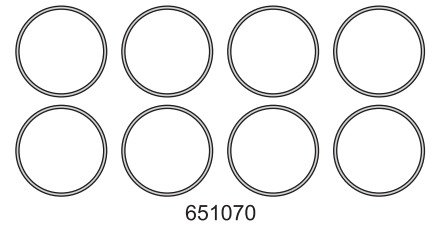

DEUTZ

DEUTZ



Motor/Engine	Cm³	HP	Ø
F 8L 413 F V8	11309		125

Deutz: Estacionarios 0302 6472 AY 0148-00
 0301 7177 UY 0147-00
 Vehicular Omnibus - Camiones
 0302 6545 AY 0148-00
 0301 7177 UY 0147-00



DIESEL

Nº OE	Descripción/Description	Mat.		Ref.
1118641	Arandela A 6 x 10 x 1 C	CU	5	
1107101	Arandela A 8.5 x 14 x 1.25 C	CU	32	
1118727	Arandela A 20 x 24 x 1.5 C	CU	2	
24211820	Retén bancada trasero 105 x 130 x 15	P	1	R651011P
24211819	Retén distribución 100 x 120 x 15	P	1	R650912P
11164594	Retén turbo ventilador 25 x 62 x 10	P	1	R650923P

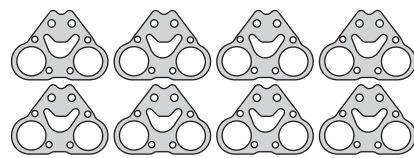

651036

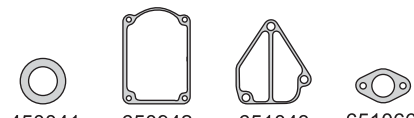

450041 650942 651043 651066

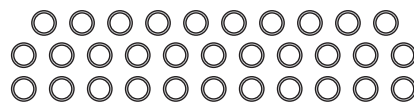

G 18 x 4



G 20 x 4



G 10 x 4

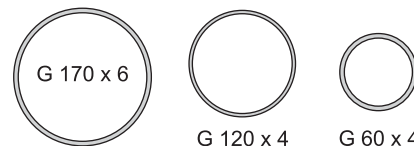

G 170 x 6

G 120 x 4

G 60 x 4

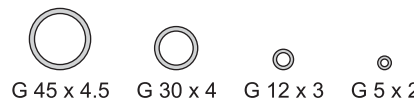

G 45 x 4.5 G 30 x 4 G 12 x 3 G 5 x 2



G 8 x 3



G 25 x 4 G 25 x 2 G 40 x 3



A 14.5 x 18 x 1.25 C

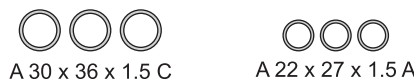

A 30 x 36 x 1.5 C A 22 x 27 x 1.5 A

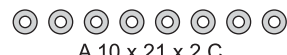

A 10 x 21 x 2 C



A 6 x 12 x 1 C

A 8 x 14 x 1.5 C

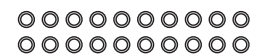

A 10 x 14 x 1.25 C



A 18 x 24 x 1.25 C A 14 x 20 x 1.25 C

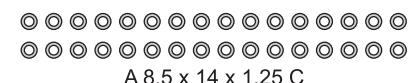

A 8.5 x 14 x 1.25 C



A 7 x 14 x 1 C A 6 x 10 x 1 C

A 20 x 24 x 1.5 C



A 8 x 11.5 x 1 C



R651011P R650912P R650923P

DEUTZ

DEUTZ



Motor/Engine	Cm³	HP	Ø
BF 3L 913	3064		102
DIESEL			

Deutz: 913 1978/81



Nº OE	Descripción/Description	Mat.	Ref.
	Jgo. de juntas para motor		660000-R
3371642	Junta tapa válvulas	NB 3	650110
	Junta para cárter	NB 1	660011
3362503	Tapa distribución	CB 1	650112
3371689	Múltiple escape	FCH 3	650115
2230704	Múltiple admisión	NB 3	650117
2231127	Lateral tubo sobrealimentador	NFT 1	650118
3362983	Soporte filtro aceite	NB 2	650129
13358	Acople filtro combustible	NB 1	650028
1216307	Arandela fijación tapa válvulas	PLAST 3	650130
	Base sobrealimentador turbo	NFT 1	650131
2134209	Tubo retorno aceite turbo	NB 1	650132
2137840	Tapa y codo múltiple admisión	NB 2	650133
3362337	Tapa trasera cigüeñal	CB 1	650134
	Arandela A 22 x 27 x 1.5 A	AL 1	650535
1231000	Tapa llenado aceite	CG 1	650135
1166053	Tapa llenado aceite	CG 1	650137
1118764	Arandela tapón cabeza cilindros A 26 x 32 x 2 A	AL 6	650138
1166103	O'ring base bomba inyectora G 74 x 3.35	GS 1	650139
3372164	Arandela bomba inyectora A 10 x 21 x 2 C	CU 3	650140
1167425	Radiador aceite G 14 x 20 x 10	GS 1	650141
1166002	O'ring tubo presión aceite G 14 x 3	GS 1	650142
	Arandela A 10 x 14 x 1 A	AL 1	650068
	Arandela A 17 x 22 x 1 A	AL 2	650243
1118675	Arandela tapa block A 12 x 16 x 1.5 A	AL 8	650144
D076031200	Arand. termostato sobre presión A 8 x 12 x 1 C	CU 6	650145
	Arandela A 10 x 16 x 1 A	AL 1	650146
2232527	Retén guía válvulas	GS 12	650147
	Arandela A 18 x 23 x 1 A	AL 1	650087
2230216	Anillo intermedio	AC 3	650170
2137256	Suplemento camisa cilindros 0.2 mm.	AC 3	650170-0.20
2232693	Suplemento camisa cilindros 0.3 mm.	AC 3	650170-0.30
	Bomba hidráulica motor	CB 1	650148
	Junta tapa válvulas	GS	650149
	Jgo. retén válvulas (6)	P 1	R650110P
	Retén bancada 115 x 140 x 16	P 1	R650111P
	Retén distribución 65 x 85 x 13	P 1	R650112P

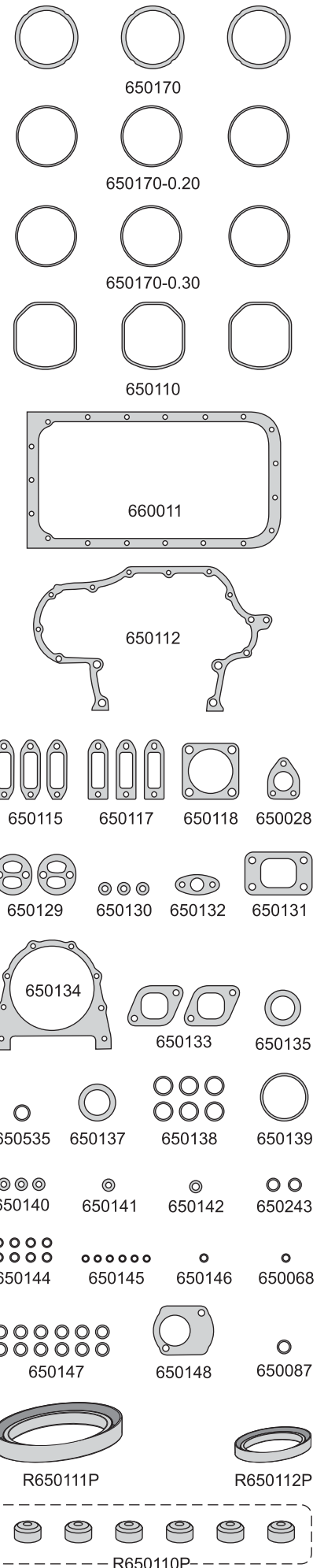

DEUTZ

DEUTZ



Motor/Engine	Cm³	HP	Ø
F4 L 913	4086	87	102

Deutz: 913 - Agrale 4.913
Turbo 4.913 1978/...



DIESEL

Nº OE	Descripción/Description	Mat.	Ref.
	Jgo. de juntas para motor	●	660100-R
	Jgo. tornillos tapa cilindros (HAS17038)		B650100
3371692	Junta tapa válvulas	NB 4	650110
	Junta para cárter	NH 1	660111
3362505	Tapa distribución	CB 1	650112
13358	Acople filtro combustible	NB 1	650028
3371689	Múltiple escape	FCH 4	650115
2230704	Múltiple admisión	NB 4	650117
2231127	Lateral tubo sobrealimentador	NFT 1	650118
3362983	Soporte filtro aceite	NB 2	650129
1216307	Arandela fijación tapa válvulas	PLAST 4	650130
	Junta base sobrealimentador	NFT 1	650131
2134209	Tubo retorno a turbo	NB 1	650132
2137840	Tapa y codo múltiple admisión	NB 2	650133
3362337	Tapa trasera cigüeñal	CB 1	650134
	Arandela A 22 x 27 x 1.5 A	AL 1	650535
1231000	Tapa llenado aceite	CG 1	650135
	Arandela A 17 x 22 x 1 A	AL 2	650243
1166053	Tapa llenado aceite	CG 1	650137
1118764	Arand. tapón cabeza cilindros A 26 x 32 x 2 A	AL 8	650138
1166103	O'ring bomba inyectora G 74 x 3.35	GS 1	650139
3372164	Arandela bomba inyectora A 10 x 21 x 2 C	CU 4	650140
1167425	Radiador de aceite	GS 1	650141
1166002	O'ring tubo presión aceite G 14 x 3	GS 1	650142
1118836	Junta tapa radiador aceite G 45.5 x 52 x 2	GS	650143
1118675	Arandela tapa block A 12 x 16 x 1.5 A	AL 8	650144
D076031200	Arandela termostato sobre presión A 8 x 12 x 1 C	CU 6	650145
2232527	Retén guía válvulas	GS 16	650147
	Arandela A 10 x 16 x 1 A	AL 1	650146
	Bomba hidráulica	CB 1	650148
	Junta tapa válvulas	GS	650149
	Arandela A 10 x 14 x 1 A	AL 1	650068
2230216	Anillos intermedio	AC 4	650170
2232693	Suplemento camisa cilindros 0.3 mm.	AC 4	650170-0.30
2137256	Suplemento camisa cilindros 0.2 mm.	AC 4	650170-0.20
	Arandela A 18 x 23 x 1 A	AL 1	650087
	Jgo. retén válvulas (8)	P 1	R660110P
	Retén bancada 115 x 140 x 16	P 1	R650111P
	Retén distribución 65 x 85 x 13	P 1	R650112P



650170



650170-0.20



650170-0.30



650110

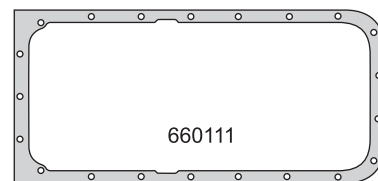

660111

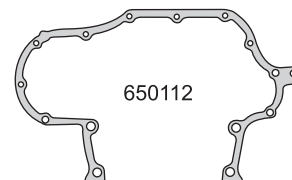

650112

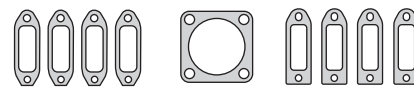

650115

650118

650117



650028

650129

650130

650132

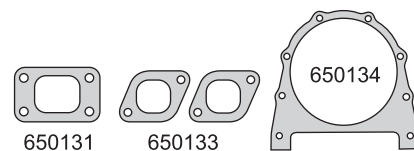

650131

650133

650134



650135

650535

650137

650139



650138

650140

650141

650142

650243

650144

650145

650146

650068

650087

650148



650147



R650111P



R650112P

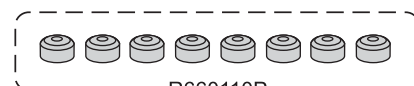

R660110P

DEUTZ

DEUTZ



Motor/Engine	Cm³	HP	Ø
BF 5L 913	5106		102

Deutz: 913 1978/...



DIESEL

Nº OE	Descripción/Description	Mat.	Ref.
	Jgo. de juntas para motor		660200-R
3371642	Junta tapa válvulas	NB	5 650110
	Junta para cárter	NB	1 660211
3362503	Tapa distribución	CB	1 650112
3371689	Múltiple escape	NFT	5 650115
2230704	Múltiple admisión	NB	5 650117
2231127	Lateral tubo sobrealimentador	NFT	1 650118
13358	Acople filtro combustible	NB	1 650028
3362983	Soporte filtro aceite	NB	2 650129
1216307	Arandela fijación tapa válvulas	PLAST	5 650130
	Base sobrealimentador	NFT	1 650131
2134209	Tubo retorno aceite	NB	1 650132
2137840	Tapa y codo múltiple admisión	NB	2 650133
3362337	Junta tapa trasera cigüeñal	CB	1 650134
	Arandela A 22 x 27 x 1.5 A	AL	1 650535
1231000	Tapa llenado aceite	CG	1 650135
1166053	Tapa llenado aceite	CG	1 650137
1118764	Arandela tapón cabeza cilindros A 26 x 32 x 2 A	AL	10 650138
3372164	Arandela bomba inyectora A 10 x 21 x 2 C	CU	5 650140
1167425	Radiador aceite G 14 x 20 x 10	GS	1 650141
1166002	O'ring tubo presión aceite G 14 x 3	GS	1 650142
	Arandela A 18 x 23 x 1 A	AL	1 650243
1118675	Arandela tapa block A 12 x 16 x 1.5 A	AL	8 650144
D076031200	Arandela ter/ sobre. A 8 x 12 x 1 C	CU	6 650145
2232527	Retén guía válvulas	GS	20 650147
	Arandela A 10 x 16 x 1 A	AL	1 650146
1166103	O'ring base G 74 x 3.35	GS	1 650139
	Bomba hidráulica motor	CB	1 650148
	Junta tapas válvulas	GS	650149
	Arandela A 10 x 14 x 1 A	AL	1 650068
2230216	Anillo intermedio	AC	5 650170
2137256	Suplemento camisa cilindros 0.2 mm.	AC	5 650170-0.20
2232693	Suplemento camisa cilindros 0.3 mm.	AC	5 650170-0.30
	Arandela A 17 x 22 x 1 A	AL	2 650087
	Jgo. retén válvulas (10)	P	1 R660210P
	Retén bancadas 115 x 140 x 16	P	1 R650111P
	Retén distribución 65 x 85 x 13	P	1 R650112P

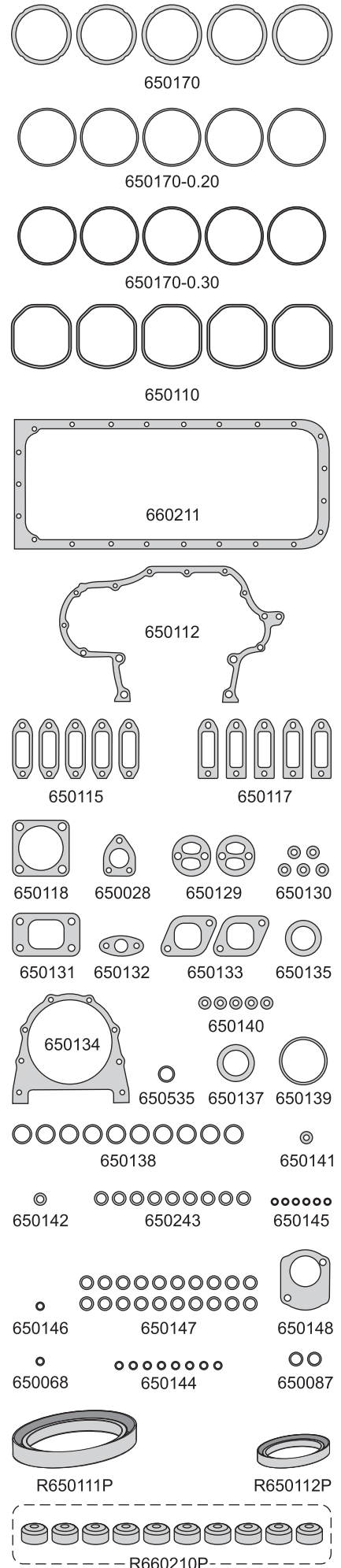

DEUTZ



taranto

Para garantizar un trabajo óptimo, utilice el Kit de Herramientas Especiales HAK12-38, con su completa línea de puntas en todas las versiones aplicables para cada modelo de cabeza de ajuste.



KIT HAK12-38

Tubos Hexagonales

6 PT Socket



Tubos Torx

Torx Socket



Tubos Estriados

12 PT Socket



Tubos con Punta Torx

Torx Socket Bit



Tubos con Punta Ribe

Ribe Socket Bit



Tubos con Punta Estriada

Torx Spline Socket Bit



Tubos con Punta Hexagonal

Hex. Socket Bit



Goniometro - Torquimetro Taranto.

Diseñado especialmente para facilitar el apriete de los tornillos de tapa de cilindros.

- HTORQ-110 - Herramienta Torquimetro 19-110NM
- HTORQ-210 - Herramienta Torquimetro 40-210NM
- HTORQ-350 - Herramienta Torquimetro 60-350NM
- HGONIOMETRO - Herramienta de Ajuste Angular - Goniometro
- HGONIOMETRO-M - Herramienta de Ajuste Angular - Goniometro Magnético



FIAT



Motor/Engine

Cm³

HP

Ø

Fiat: Tractor Someca 1965/74

M45 - 450 - 55
Super Son

4156

105

DIESEL

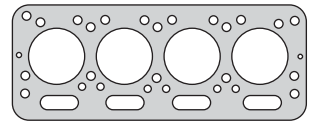

700008



700010

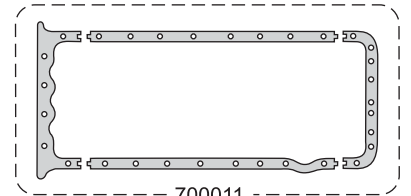

700011

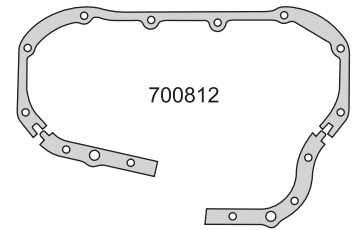

700812

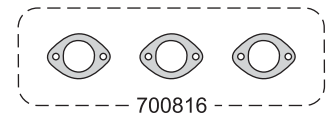

700816

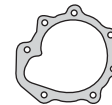

700014



700818



700019



700829



700827

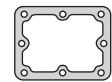

700031



700032



700832



700034



700833



700035



700837



700838



700038



700834

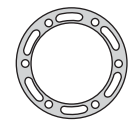

700840

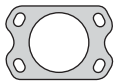

310443



700543



700544



500045



700070-0.07

Nº OE	Descripción/Description	Mat.	Ref.
	Jgo. de juntas para motor		700000
70483	Junta tapa cilindros Ø 109 \pm 1.80	CNC	1 700008
	Junta tapa cilindros Ø 109 \pm 1.80	NFT	1 700007
72840	Junta tapa válvulas superior	CG	1 700010
546295	Jgo. junta para cárter (4)	NB	1 700011
8817760	Tapa distribución	NB	1 700812
540456	Bomba de agua	NH	1 700014
3/0187486	Jgo. múltiple escape (3)	NFT	1 700816
71227	Salida de escape	NFT	1 700818
	Placa bomba de agua	NB	1 700019
38814976	Tubería lubricación aceite	NB	1 700827
549417	Codo termostato	NB	1 700829
546297	Tapa lateral cárter chico	NB	1 700031
544020	Codo admisión aire motor	NB	1 700032
1049122	Entre caja bomba reguladora	NB	1 700832
760203	Tapa reguladora bomba inyectora	NB	1 700833
540461	Unión bomba agua	NB	1 700034
583596	Alojamiento bomba elevadora	NB	1 700834
561999	Tapa árbol y engr. cambio	NB	1 700035
3/8814976	Cañería termostato a bomba	NB	1 700837
	Arandela conductor 57.5 x 23.5	CG	1 700038
8816260	Tubería agua a block	NB	2 700838
114802	Soporte fijación comando bomba	NB	1 700840
	Base bomba inyectora	NB	1 310443
113909	Apoyo filtro aceite	NB	1 700543
115036	Boca carga aceite	NB	1 700544
746153	Bomba alimentación	NB	1 500045
	Jgo. suplemento camisa cilindros (0.07) (4)	CU	1 700070-0.07
	Jgo. suplemento camisa cilindros (0.10) (4)	CU	1 700070-0.10

FIAT / IVECO

FIAT



Motor/Engine	Cm³	HP	Ø
780 - R - AE	6872		125

Fiat: Tractor 1962/69



DIESEL

Nº OE	Descripción/Description	Mat.	Ref.
	Jgo. de juntas para motor	●	700100
583529	Junta tapa cilindros Ø 126.5 ± 1.80	CNC	1 700108
539741	Junta tapa válvulas superior	CG	1 700110
573228	Junta para cárter	NB	1 700111
539800	Tapa engranaje bomba inyectora	NB	1 700112
539672	Cuerpo soporte bomba de agua	NB	1 700114
	Jgo. múltiple escape (3)	NFT	1 700116
569966	Jgo. múltiple admisión (2)	NFT	1 700117
539120	Salida de escape	NFT	1 700118
573275	Codo termostato	NB	1 700119
	Boca carga aceite a block	CG	1 700127
551624	Boca carga aceite	NB	1 700133
539797	Tapa delantera block	NB	1 700135
586019	Tapa botadores superior	NB	2 700136
573282	Tapa botadores inferior	NB	2 700137
768673	Entre caja y bomba reguladora	NB	1 700138
581961	Soporte filtro aceite	NB	1 700139
20344	Caja dispositivo arranque	NB	1 700140
15740	Base block motor arranque	NB	1 700141
581960	Cuerpo filtro aceite	NB	1 700142
539819	Soporte cojinetes	NB	1 700143
551494	Tapa engranaje reenvío 0.5	NB	1 700144
542368	Cierre conducto bomba aceite	NB	1 700145
	Arandela conducto superior	CG	1 700146
539706	Tapa montaje árbol levas	NB	1 700147
573233	Filtro succión	NB	1 700148
	Caño anterior bomba agua	NB	2 700149
	Caño posterior bomba agua	NB	1 700151
	Suplemento bancada	SNA	16 700158
552604	Tapa engranaje reenvío 1.5	NB	1 700162
	Reductor alta y baja	NB	700163
	Superior tapa diferencial	NB	700164
	Acople diferencial	NB	700165
	Jgo. suplemento camisa cilindros (0.07) (4)	CU	1 700170-0.07
	Jgo. suplemento camisa cilindros (0.10) (4)	CU	700170-0.10

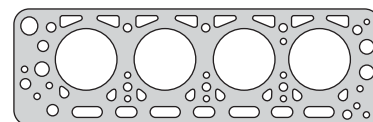

700108

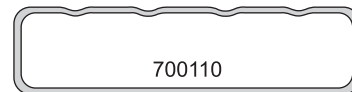

700110

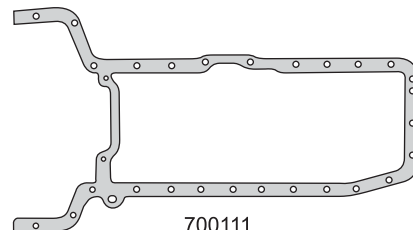

700111

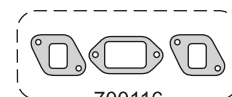

700116

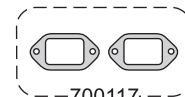

700117

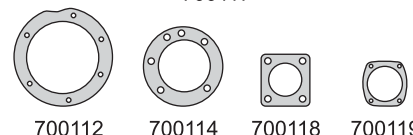

700112

700114

700118

700119



700127

700133

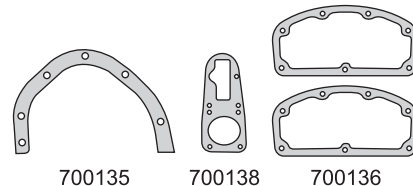

700135

700138

700136

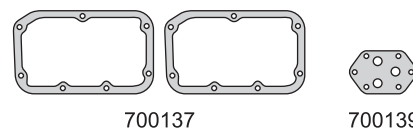

700137

700139

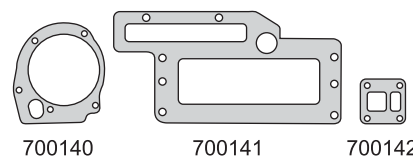

700140

700141

700142



700143

700144

700145

700146

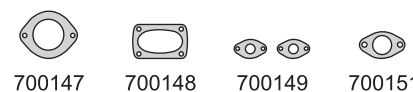

700147

700148

700149

700151



700158



700162



700170-0.07

FIAT / IVECO

FIAT



Motor/Engine	Cm³	HP	Ø
840 - 900 - 1100 CP3 - 900E	7412	165	110

Fiat: Tractor - CP3 1972/80



DIESEL

Nº OE	Descripción/Description	Mat.	Ref.
	Jgo. de juntas para motor		700200
8818605	Junta tapa cilindros Ø 114.5 \pm 2.00	T	1 700207
8818605	Junta tapa cilindros Ø 114 \pm 1.86	CNC	700208
8304703	Junta tapa válvulas superior	CG	2 700810
8308535	Junta para cárter	NH	1 700211
8817760	Tapa distribución	NB	1 700812
8818228	Tapa bomba de agua	NB	1 700814
	Jgo. múltiple escape (3)	FCH	1 700215
8308543	Salida de escape	NFT	1 700218
8818239	Placa bomba de agua	NB	1 700819
8817468	Base bomba aceite	NB	2 700227
3/8814976	Tubería lubricación aceite	NB	2 700827
549417	Codo termostato	NB	1 700829
1049122	Entre caja y bomba reguladora	NB	1 700832
760203	Tapa reguladora bomba inyectora	NB	1 700833
583596	Tapa alojamiento bomba elevadora	NB	1 700834
8307497	Bomba aplicación levante hidráulico	NB	1 700235
3/8814976	Cañería termostato a bomba	NB	1 700837
8816260	Tubería agua a block	NB	4 700838
	Reguladora bomba inyectora	NB	1 700839
114802	Soporte fijación comando bomba	NB	1 700840
8308640	Tapa alojamiento bomba hidráulica	NB	2 700841
8828172	Retén aceite bancada cigüeñal	SNA	700842
	Suplemento bancada	SNA	12 700158
	Junta base bomba inyectora	NB	1 310443
	Jgo. suplemento camisa cilindros (0.05) (6)	CU	1 700270-0.05
	Jgo. suplemento camisa cilindros (0.07) (6)	CU	700270-0.07
	Jgo. suplemento camisa cilindros (0.10) (6)	CU	700272-0.10

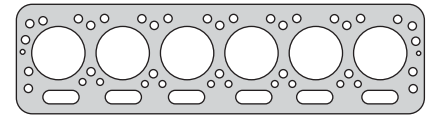

700207



700810

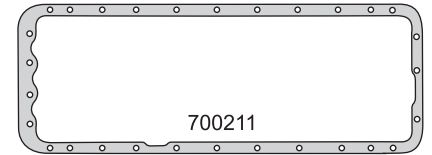
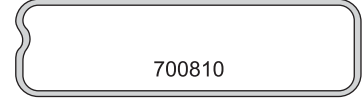

700211

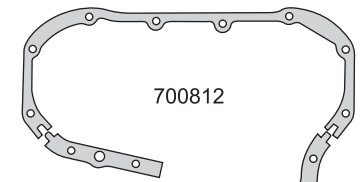

700812

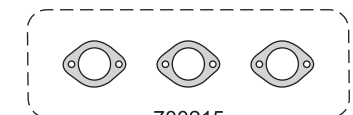

700814

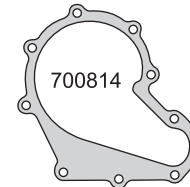

700819

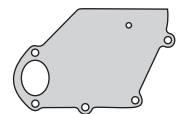

700227



700827



700218



700829



700832

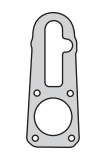

700833



700834



700235



700837



700838



700839



700840



700841

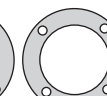

310443



700158



700270-0.05

FIAT / IVECO

FIAT



Motor/Engine	Cm³	HP	Ø
650 - 700 CO3	3421 4397		110 108

Fiat: Tractor Someca - CN3 1961/70
Someca M45/M50 - Super Som 55/46A
Tigrotto 1969/...



DIESEL

Nº OE	Descripción/Description	Mat.	Ref.
	Jgo. de juntas para motor		700300
	Junta tapa cilindros Ø 112.5 ± 1.80	CNC	1 700308
72840	Junta tapa válvulas superior	CG	1 700010
546295	Jgo. junta para cárter (4)	NB	1 700011
	Tapa distribución	NB	1 700812
540456	Bomba de agua	NB	1 700014
8818228	Bomba de agua	NB	700814
	Jgo. múltiple escape (3)	NFT	1 700316
8308543	Salida de escape	NFT	1 700818
	Placa bomba de agua	NB	1 700019
8818239	Placa bomba de agua	NB	700819
	Unión caño de agua	NB	1 700327
38814976	Tubería lubricación aceite	NB	2 700827
549417	Codo termostato	NB	1 700829
	Junta tapa lateral cárter	NB	1 700031
	Codo admisión aire	NB	1 700032
1049122	Entre caja y bomba reguladora	NB	1 700832
760203	Tapa reguladora bomba inyectora	NB	1 700833
	Codo agua	NB	1 700034
	Unión bomba de agua	NB	700334
583596	Tapa alojamiento bomba elevadora	NB	1 700834
8817453	Soporte placa filtro aceite	NB	1 700835
	Cañería termostato	NB	1 700837
	Arandela conducto	CG	1 700038
8816260	Tubería agua a block	NB	2 700838
	Soporte fijación comando bomba	CB	1 700440
	Codo agua	NB	1 700341
541065	Cuenta horas	CB	700441
8828172	Retén aceite bancada cigüeñal	SNA	700842
113909	Apoyo filtro aceite	NB	1 700543
115036	Boca carga aceite	NB	1 700544
	Bomba alimentación	NB	1 500045
	Junta base bomba inyectora	NB	1 310443
	Jgo. suplemento camisa cilindros (0.05) (4)	CU	1 700370-0.05
	Jgo. suplemento camisa cilindros (0.07) (4)	CU	700370-0.07
	Jgo. suplemento camisa cilindros (0.10) (4)	CU	700370-0.10

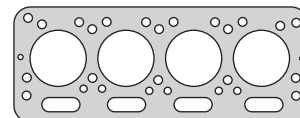

700308

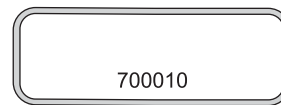

700010

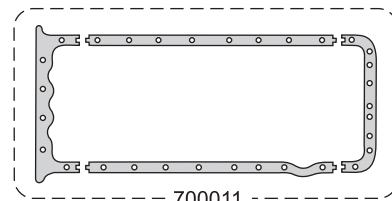

700011

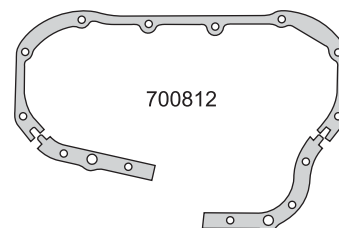

700812

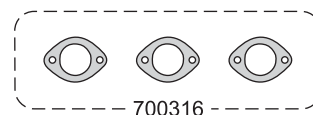

700316

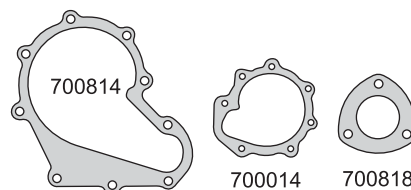

700814

700014

700818

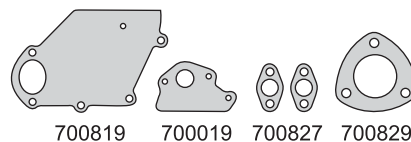

700819

700019

700827

700829

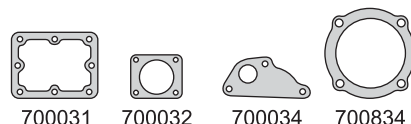

700031

700032

700034

700834

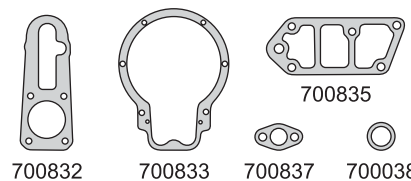

700832

700833

700837

700038

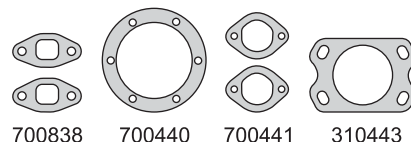

700838

700440

700441

310443

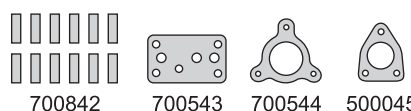

700842

700543

700544

500045



700370-0.05

FIAT / IVECO

FIAT



Motor/Engine	Cm³	HP	Ø
DA - 50 - 40	3456		100

Fiat: Tractor Someca - Leoncino 1950/...



DIESEL

Nº OE	Descripción/Description	Mat.	Ref.
	Jgo. de juntas para motor		700400
115362	Junta tapa cilindros Ø 104 ±1.80	CNC	700408
72840	Junta tapa válvulas superior	CG	700410
546295	Jgo. junta para cárter (4)	NB	700011
8817760	Tapa distribución (3)	NB	700812
540456	Bomba de agua	NB	700014
3/0187486	Jgo. múltiple escape (3)	NFT	700816
71227	Salida de escape	NFT	700818
	Placa bomba de agua	NB	700019
38814976	Tubería lubricación aceite	NB	700827
549417	Codo termostato	NB	700829
546297	Junta tapa lateral cárter chico	NB	700031
544020	Codo admisión aire motor	NB	700032
540461	Unión bomba de agua	NB	700034
170245	Soporte bomba aceite	CB	700435
599741	Junta tapa válvulas lateral	CB	700436
3/8814976	Cañería termostato a bomba	NB	700837
	Arandela conductor 57.5 x 23.5	CG	700038
8816260	Tubería agua a block	NB	700838
187341	Bomba aceite	CB	700439
	Soporte fijación comando bomba	CB	700440
541065	Cuenta horas	CB	700441
3/10187185	Filtro aceite	CB	700442
113909	Apoyo filtro aceite	NB	700543
746153	Bomba alimentación	NB	500045
	Junta base bomba inyectora	NB	310443
	Jgo. suplemento camisa cilindros (0.050) (4)	CU	700470-0.050
	Jgo. suplemento camisa cilindros (0.075) (4)	CU	700470-0.075
	Jgo. suplemento camisa cilindros (0.100) (4)	CU	700470-0.100

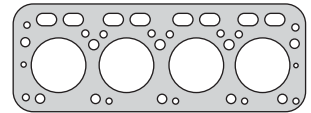

700408



700410

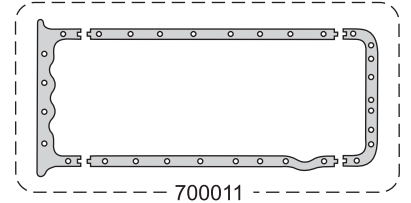

700011

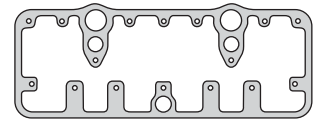

700436

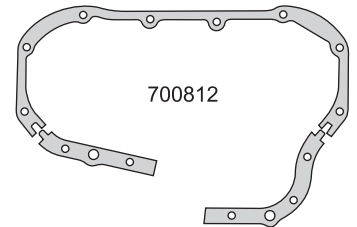

700812

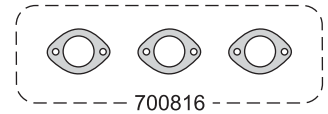

700816

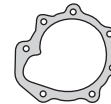

700014



700818



700019



700829



700827

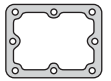

700031



700032



700034



700435



700837



700838



700038

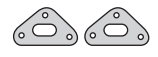

700439

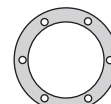

700440



700441



700442



700543

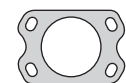

310443



500045



700470-0.050

FIAT / IVECO

FIAT



Motor/Engine	Cm³	HP	Ø
700E - 800E CO3 - 640 - 740	5401	90/106	115

Fiat: Tractor - CO3 1971/80

DIESEL



Nº OE	Descripción/Description	Mat.	Ref.
	Jgo. de juntas para motor		700500
8824633	Junta tapa cilindros Ø 118 \pm 2.00	NFT	1 700507
8824633	Junta tapa cilindros Ø 118 \pm 1.86	CNC	700508
8307703	Junta tapa válvulas superior	CG	1 700510
8307706	Junta para cárter	NB	1 700511
8817760	Tapa distribución	NB	1 700812
8818228	Tapa bomba de agua	NB	1 700814
	Jgo. múltiple escape (3)	FCH	1 700215
8308543	Salida de escape	NFT	1 700218
8818239	Placa bomba de agua	NB	1 700819
8817468	Base bomba aceite	NB	2 700227
38814976	Tubo lubricación aceite	NB	2 700827
549417	Codo termostato	NB	1 700829
1049122	Entre caja y bomba reguladora	NB	1 700832
760203	Tapa reguladora bomba inyectora	NB	1 700833
583596	Tapa alojamiento bomba elevadora	NB	1 700834
8307497	Bomba aplicación levante hidráulico	NB	1 700235
8817453	SopORTE placa filtro aceite	NB	1 700835
3/8814976	Cañería termostato a bomba	NB	1 700837
8816260	Tubería agua a block	NB	1 700838
1049197	Regulador bomba inyectora	NB	1 700839
114802	SopORTE fijación comando bomba	NB	1 700840
8308640	Tapa alojamiento bomba hidráulica	NB	1 700841
8828172	Retén aceite bancada cigüeñal	SNA	700842
541353	Junta base bomba inyectora	NB	1 310443
113909	Apoyo filtro aceite	NB	1 700543
115036	Boca carga aceite	NB	1 700544
540456	Tapa bomba agua	NB	1 700545
	Válvula rotativa		700546
	Suplemento bancada	SNA	12 700158
	Jgo. supl. camisa cilindros (0.050) pollera larga (4)	CU	1 700570-0.050
	Jgo. supl. camisa cilindros (0.075) pollera larga (4)	CU	700570-0.075
	Jgo. supl. camisa cilindros (0.100) pollera larga (4)	CU	700570-0.100
	Jgo. suplemento camisa cilindros (1.00)	CU	700570-1.00
	Jgo. suplemento camisa cilindros (3.09)	AC	700570-3.09
	Jgo. suplemento camisa cilindros (3.12)	AC	700570-3.12
	Jgo. suplemento camisa cilindros (3.15)	AC	700570-3.15
	Jgo. suplemento camisa cilindros (3.18)	AC	700570-3.18
	Jgo. suplemento camisa cilindros (3.21)	AC	700570-3.21
	Jgo. suplemento camisa cilindros (3.24)	AC	700570-3.24
	Jgo. suplemento camisa cilindros (3.27)	AC	700570-3.27
	Jgo. suplemento camisa cilindros (3.30)	AC	700570-3.30
	Jgo. suplemento camisa cilindros (3.33)	AC	700570-3.33

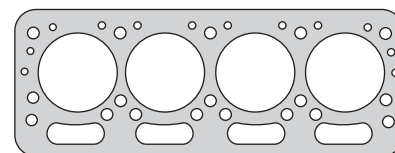

700507

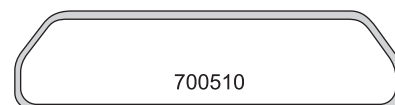

700510

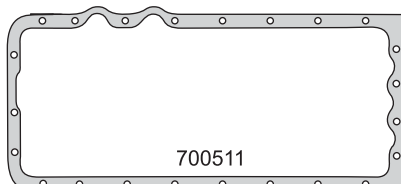

700511

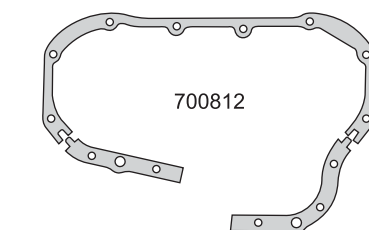

700812

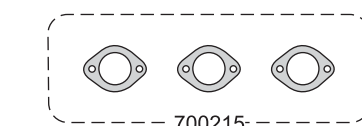

700215

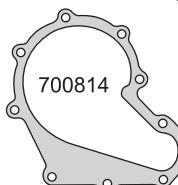

700814

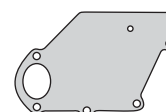

700819



700218



700227



700827



700829

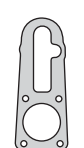

700832



700833



700834



700235

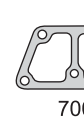

700835

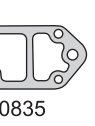

700837



700838



700839



700840



700841



310443



700544



700545



700543



700158



700570-0.05

FIAT / IVECO

FIAT



Motor/Engine	Cm³	HP	Ø
U25 - 211R - CD	1135		85

Fiat: Tractor U25 1957/62
Tractor 211R 1962/65



DIESEL

Nº OE	Descripción/Description	Mat.	Ref.
556247	Jgo. de juntas para motor		700600
531316	Junta tapa cilindros Ø 87 ± 1.40	NFT	1 700605
561377	Junta tapa válvulas	CG	1 700610
561379	Jgo. junta para cárter (4)	CG	1 700611
893339	Tapa distribución	CB	1 700612
561233	Placa distribución	NB	1 700613
561507	Tapa bomba de agua	CB	1 700614
860639	Jgo. múltiple admisión y escape (2)	FCH	1 700615
561234	Salida de escape	FCH	1 700618
561358	Entre base bomba de agua	NB	1 700619
561352	Eje mando bomba inyectora	CB	1 700628
561353	Sop. post. bancada cigüeñal	NB	2 700629
561310	Tapa caja reductor	CB	1 700633
561361	Soporte bomba aceite	CB	2 700435
1/26828/80	Tapa inspección distribución	CB	1 700637
563414	Aspiración bomba aceite	CB	1 700639
1/26833/80	Entrada agua	CB	1 700640
746153	Salida agua	CB	1 700641
541353	Junta base bomba inyectora	NB	1 310443
561377	Bomba alimentación	NB	1 500045
563755	Jgo. junta para cárter		700660
	Base carburador motor arranque	NB	1 700765

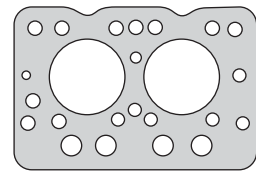

700605

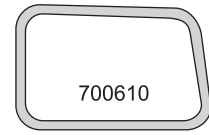

700610

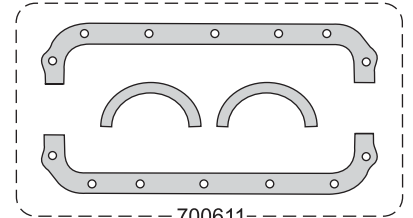

700611

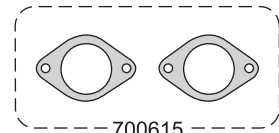

700615

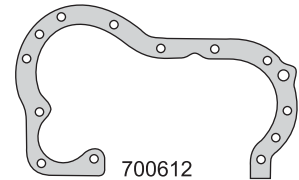

700612

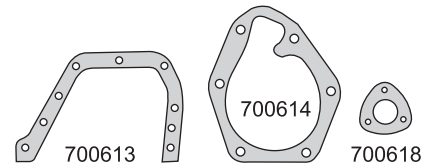

700613

700614

700618

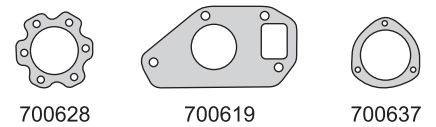

700628

700619

700637

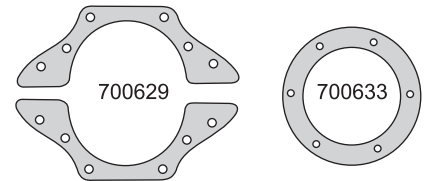

700629

700633

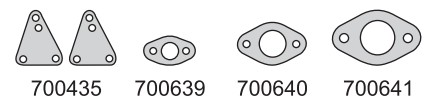

700435

700639

700640

700641



310443

500045

700765

FIAT / IVECO

FIAT



Motor/Engine	Cm³	HP	Ø
60 RL	6546		122

Fiat: Tractor 1955/...



DIESEL

Nº OE	Descripción/Description	Mat.	Ref.
	Jgo. de juntas para motor		700700
	Junta tapa cilindros Ø 126 ±1.80	CNC	1 700708
539741	Junta tapa válvulas superior	CG	1 700110
	Jgo. junta para cárter (3)	NB	1 700711
539800	Tapa engranaje bomba inyectora	NB	1 700112
539672	Cuerpo soporte bomba de agua	NB	1 700114
	Jgo. múltiple escape (3)	NFT	1 700116
569966	Jgo. múltiple admisión (2)	NFT	1 700117
539120	Salida de escape	NFT	1 700118
573275	Codo termostato	NB	1 700119
	Boca carga aceite a block	CG	1 700127
551624	Boca carga aceite	NB	1 700133
539797	Tapa delantera a block	NB	1 700135
586019	Tapa botadores superior	NB	2 700136
573282	Tapa botadores inferior	NB	2 700137
20344	Caja dispositivo arranque	NB	1 700140
15740	Base block motor arranque	NB	1 700141
581960	Cuerpo filtro aceite	NB	1 700142
539819	Soporte cojinetes	NB	1 700143
551494	Tapa engranaje reenvío	NB	1 700144
	Arandela conducto superior	CG	1 700146
539706	Tapa montaje árbol de levas	NB	1 700147
	Cañería bomba aceite	NB	1 800048
	Caño anterior bomba agua	NB	2 700149
	Caño posterior bomba agua	NB	1 700151
552604	Tapa engranaje reenvío	NB	1 700162
	Bomba alimentación	NB	1 700763
	Tapa totalizador horas	NB	2 700764
	Base carburador motor arranque	NB	1 700765
	Tapa registro cárter	NB	1 700766
	Jgo. suplemento camisa cilindros (4)	CU	1 700170-0.07

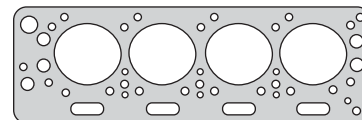

700708

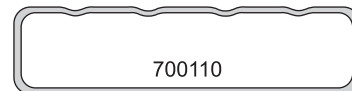

700110

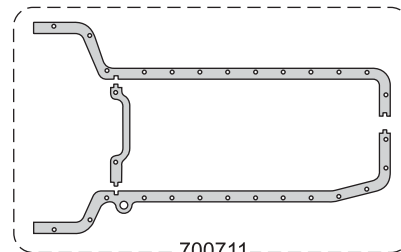

700711

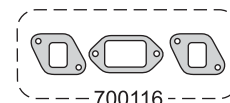

700116

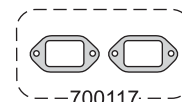

700117

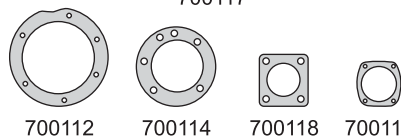

700112

700114

700118

700119

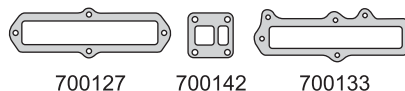

700127

700142

700133

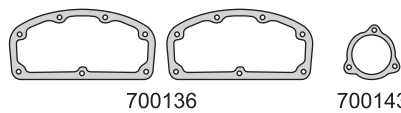

700136

700143

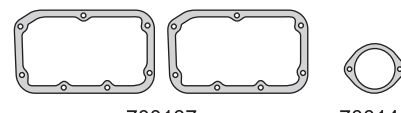

700137

700144

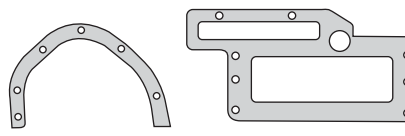

700135

700141

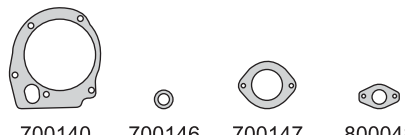

700140

700146

700147

800048

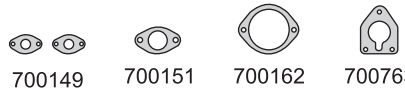

700149

700151

700162

700763

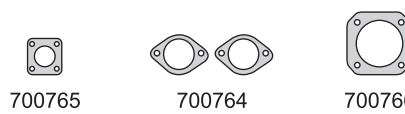

700765

700764

700766



700170-0.07

FIAT / IVECO

FIAT



Motor/Engine	Cm³	HP	Ø
CN3	3421		110
CN4	3705		110

Fiat: Tractor 400 E.V.U - 500 - Super 600E
480 1969/80



DIESEL

Nº OE	Descripción/Description	Mat.	Ref.
	Jgo. de juntas para motor		700800
8823404	Junta tapa cilindros Ø 114 \pm 2.00	NFT	1 700807
8823404	Junta tapa cilindros Ø 114 \pm 1.86	CNC	700808
8304703	Junta tapa válvulas	CG	1 700810
8304242	Jgo. junta para cárter (4)	NB	1 700811
8817760	Tapa distribución	NB	1 700812
8818228	Tapa bomba de agua	NB	1 700814
	Jgo. múltiple escape	NFT	700815
	Jgo. múltiple escape (3)	NFT	1 700816
71227	Salida de escape	NFT	1 700818
8818239	Placa bomba de agua	NB	1 700819
	Tubería lubricación aceite	NB	1 700827
549417	Codo termostato	NB	1 700829
1049122	Entre caja bomba reguladora	NB	1 700832
760203	Tapa reguladora bomba inyectora	NB	1 700833
583596	Tapa alojamiento bomba elevadoraz	NB	1 700834
8817453	Soporte placa filtro	NB	1 700835
3/8814976	Cañería termostato a bomba	NB	1 700837
8816260	Tubería agua a block	NB	2 700838
	Reguladora bomba inyectora	NB	1 700839
	Soporte fijación comando bomba	NB	1 700840
	Tapa alojamiento bomba hidráulica	NB	1 700841
8828172	Retén aceite bancada cigüeñal	SNA	700842
541353	Junta base bomba inyectora	NB	1 310443
	Junta para cárter enterizo	NB	700845
	Jgo. juntas caja velocidades	VS	700950
	Suplemento bancada	SNA	12 700158
	Jgo. suplemento camisa cilindros (3)	CU	1 700270-0.05
	Jgo. suplemento camisa cilindros (3)	CU	700270-0.07
	Jgo. suplemento camisa cilindros (3)	CU	700270-0.10

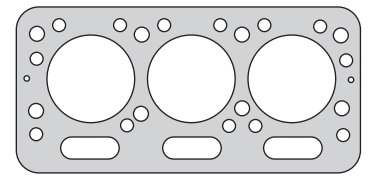

700807



700810

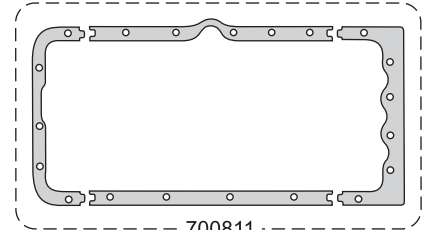

700811

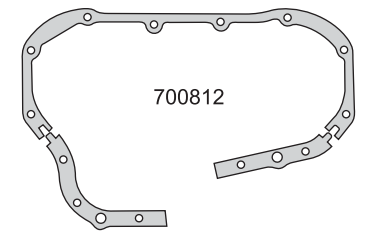

700812

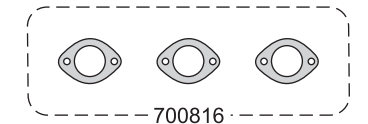

700816

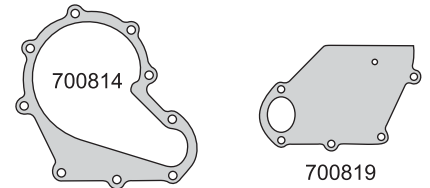

700814

700819

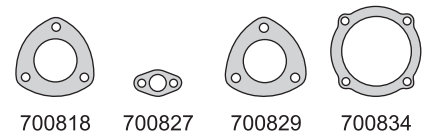

700818

700827

700829

700834

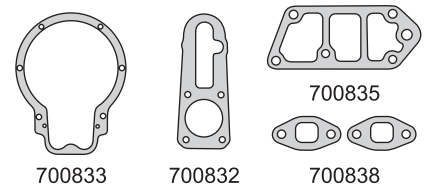

700833

700832

700835

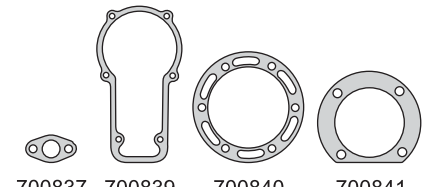

700837

700839

700840

700841

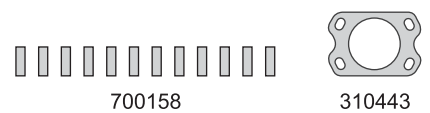

700158

310443



700270-0.05

FIAT / IVECO

FIAT



Motor/Engine Cm³ HP Ø

615 2270 40 85

Fiat: Tractor 411R - 411T - 431R 1959/85

DIESEL



Nº OE	Descripción/Description	Mat.	Ref.
	Jgo. de juntas para motor		700900
566236	Junta tapa cilindros Ø 86 ± 1.65	CNC 1	700908
565468	Junta tapa válvulas superior	CG 1	700910
563621	Jgo. junta para cárter (4)	CB 1	700911
561379	Tapa distribución	CB 1	700612
893339	Placa distribución	NB 1	700613
565395	Tapa bomba de agua	NB 1	700914
	Jgo. múltiple escape (3)	NFT 1	700916
565481	Jgo. múltiple admisión (2)	NFT 1	700917
568012	Salida de escape	NFT 1	700918
565396	Entre block y bomba de agua	NB 1	700919
565458	Apoyo filtro aceite	NB 1	700927
561358	Eje mando bomba inyectora	CB 1	700628
565153	Tapa asiento bomba levante hidráulico	CB 1	700933
563611	Junta para cárter chico	CB 1	700934
565490	Termostato		700935
565443	Junta tapa válvulas lateral	CG 1	700936
561361	Tapa inspección tapa distribución	CB 1	700637
541353	Junta base bomba inyectora	NB 1	310443
746153	Bomba alimentación	NB 1	500045
	Jgo. juntas caja de velocidades	VS	700950
563755	Base cuenta horas	NB 1	700765

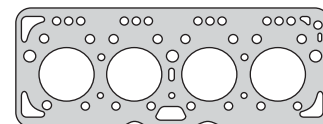

700908

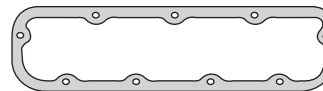

700910

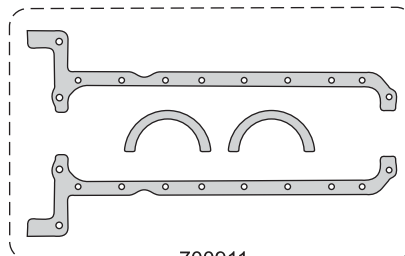

700911

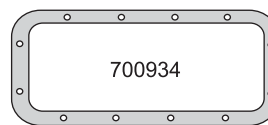

700934



700936

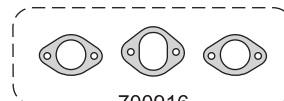

700916

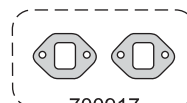

700917

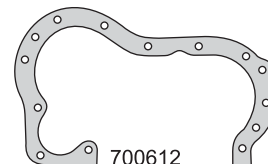

700612

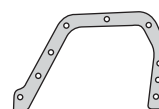

700613



700914

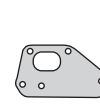

700919



700918



700927



700628

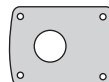

700933



700935



700637



310443



500045



700765

FIAT / IVECO

FIAT



Motor/Engine	Cm³	HP	Ø
673N - CP 840 - 900	7412		110
DIESEL			

Fiat: Camión 1964/83



Nº OE	Descripción/Description	Mat.	Ref.
	Jgo. de juntas para motor		710100
	Junta tapa cilindros Ø 114.5 \pm 2.00	NFT 1	700207
	Junta tapa cilindros Ø 114 \pm 1.86	CNC	700208
8304703	Junta tapa válvulas superior	CG 2	700810
	Junta para cárter	NB 1	710111
8817760	Tapa distribución	NB 1	700812
	Bomba de agua	NB 1	710114
	Jgo. múltiple escape (3)	FCH 1	700215
8308543	Salida de escape	NFT 1	700218
	Placa bomba de agua	NB 1	710119
8817468	Base bomba aceite	NB 2	700227
	Tubería lubricación aceite	NB 2	700827
	Brida bomba combustible	NB 1	710128
	Filtro aceite	NB 1	710129
1049122	Entre caja y bomba reguladora	NB 1	700832
760203	Tapa reguladora bomba inyectora	NB 1	700833
	Tapa inspección distribución	CB 1	710134
	Enfriador aceite	NB 1	710135
3/8814976	Cañería termostato a bomba	NB 1	700837
8816260	Tubería agua a block	NB 4	700838
	Reguladora bomba inyectora	NB 1	700839
	Tapa asiento bomba levante hidráulica	CB 1	700933
	Carcaza tapa trasera	CB 1	710140
	Reguladora bomba inyectora	NB 2	710141
8828172	Retén aceite bancada cigüeñal	SNA	700842
	Cañería codo bomba agua	NB 2	710142
	Bomba agua a cañería	NB 1	710143
541353	Junta base bomba inyectora	NB 1	310443
	Caño agua	NB 2	710144
	Bomba alimentación	NB 1	500045
	Jgo. juntas caja de velocidades	VS	710150
	Suplemento bancada	SNA 12	700158
	Jgo. juntas compresor Marelli	VS 1	710168
	Jgo. suplemento camisa cilindros (0.05) (6)	CU	700270-0.05
	Jgo. suplemento camisa cilindros (0.07) (6)	CU	700270-0.07
	Jgo. suplemento camis cilindros (0.10) (6)	CU	700270-0.10

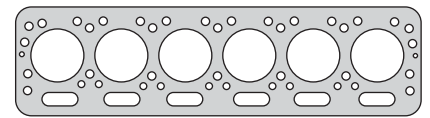

700207



700810

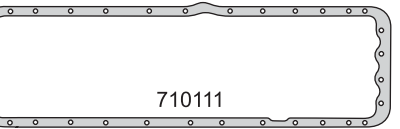

710111

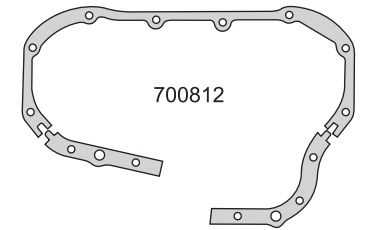

700812

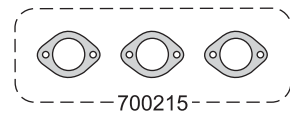

700215

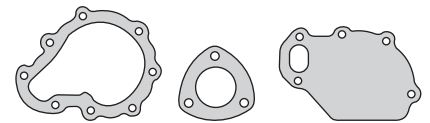

710114

700218

710119

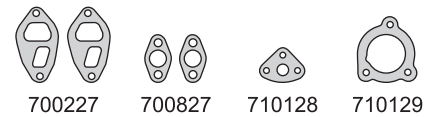

700227

700827

710128

710129

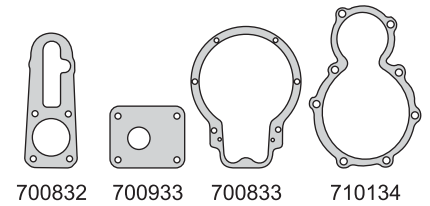

700832

700933

700833

710134

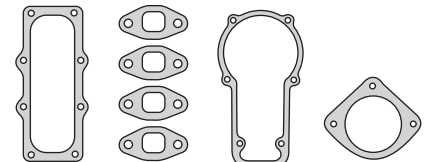

710135

700838

700839

710140

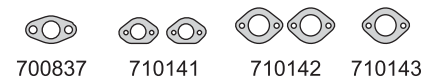

700837

710141

710142

710143



700158

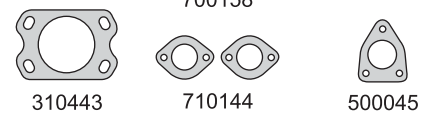

310443

710144

500045



700270-0.05

FIAT / IVECO

FIAT



Motor/Engine **Cm³** **HP** **Ø**

Motorino 55/60/788R **665** **75**

Fiat: Motor Arranque - Tractor 1955/74

DIESEL

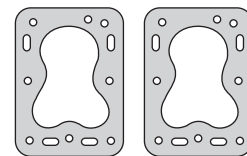

710205

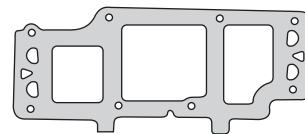

710215

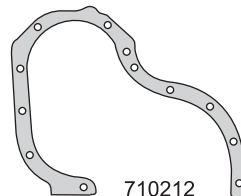

710212



710218



710229







710230

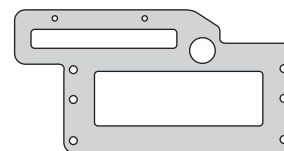

700765



700141

Nº OE	Descripción/Description	Mat.	Ref.
	Jgo. de juntas para motor 		710200
15649	Junta tapa cilindros Ø 79 ± 1.40 	NFT	2 710205
15826	Tapa distribución 	CB	1 710212
15737	Múltiple escape 	NB	1 710215
15881	Salida de escape 	NFT	1 710218
15818	Soporte post. cigüeñal	CB	1 710229
	Dispositivo arranque	CB	1 710230
15740	Base block cilindro	NB	1 700141
563755	Base carburador	NB	1 700765

FIAT / IVECO

FIAT IVECO



Motor/Engine	Cm³	HP	Ø
8210.02	13798	260	137

Fiat: Camión 619N1 - 697N TB
Bus 391 - 691 - 319N
Bus 221A 1970/...



DIESEL

Nº OE	Descripción/Description	Mat.	Ref.
	Jgo. de juntas para motor		800000-R
	Jgo. de juntas para motor		800001
	Jgo. de juntas superior		800095
4680722	Jta. tapa cilindros Ø 144 \geq 1.40	NFT	2 800007
	Jta. tapa cilindros Ø 139 \geq 1.25	ACT	800008
	Jta. tapa cilindros Ø 139 \geq 1.25	AC	800008-CU
4654928/29	Jgo. de tornillos para tapas de cilindros		B800000
4530174	Junta tapa válvulas superior	NB	2 2 800010
4541081	Jgo. junta para cárter (3)	NB	1 800011
4628500	Tapa distribución	NB	1 800012
4537363	Placa distribución	NB	1 800013
4006034	Bomba de agua	NB	1 800014
4871982	Jgo. múltiple escape (6)	FCH	800015
4871982	Jgo. múltiple escape (6)	CHA	1 1 800015L
	Jgo. múltiple admisión (6)	NB	1 1 800017
4530835	Salida de escape	CHA	2 2 800018L
4530835	Salida de escape	FCH	800018
4606046	Entrada bomba de agua	NB	1 1 800019
	Porta retén bancada	NB	1 800029
4547637	Tubo bomba agua	NB	1 1 800030
4606094	Tubo termostato a bomba	NB	2 2 800031
4614887	Cuerpo termostato	NB	1 800032
4616568	Entrada y salida agua	NB	6 6 800033
4621025	Cambiador temperatura	NB	2 2 800034
	Salida cañería agua		800035
4615254	Termostato	NB	1 1 800036
4617079	Tubería entrada agua	NB	20 20 800037
4632138	Cañería bomba aceite a block	NB	1 800038
768673	Entre caja y bomba reguladora		800039
4530123	Tapa registro válvulas	NB	1 800040
4526340	Soporte árbol comando bomba inyectora	NB	1 1 800041
4638506	Cuerpo respiración motor	NB	2 800042
4638621	Tapa respiración motor	NB	2 800043
4643730	Tromba de admisión	NB	1 800044
4511313	Compresor Marelli	NB	1 800045
4606042	Entrada bomba agua	NB	1 1 800046
4575911	Cañería agua	NB	1 800047
	Cañería bomba aceite	NB	1 800048
	Cañería lubricación	NB	4 800049
	Jgo. juntas caja de velocidades	VS	800050
	Pegada (71162A/71162B)	NH	1 710162
	Pegada (71163A/71163B)	NH	1 710163
	Jgo. reparación compresor Burmor s/v	VS	800066
	Jgo. juntas cañerías refrigeración	VS	800067
	Jgo. juntas compresor Marelli (11)	VS	1 800068
	Jgo. reparación compresor Burmor	VS	800069
	Retorno de agua	NB	4 4 800087
	Retorno de agua	NB	2 2 800088
	Soporte bomba hidráulica	NB	1 800089
	Soporte bomba hidráulica	NB	1 800090
	Bomba hidráulica	NB	1 800091
	Base compresor	NB	1 800092
	Intermedia compresor	CB	1 800093

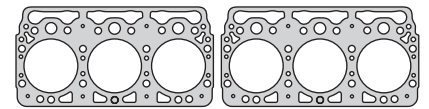

800007

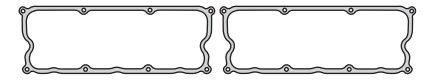

800010

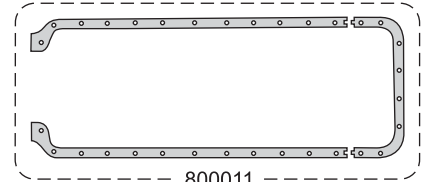

800011

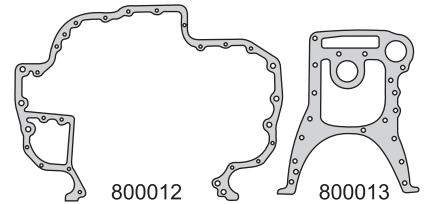

800012

800013

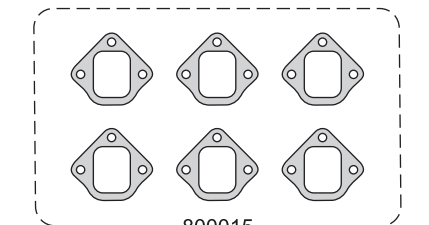

800015

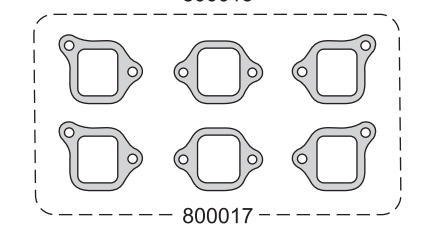

800017

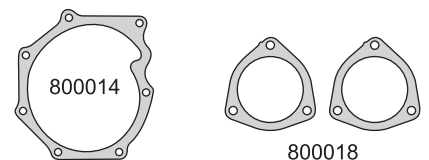

800014

800018

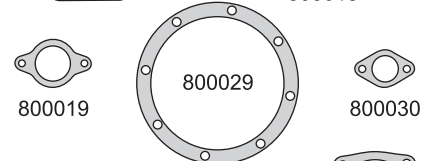

800019

800029

800030



800031

800034

800032



800033

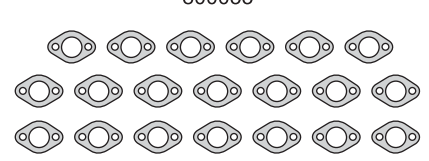

800037

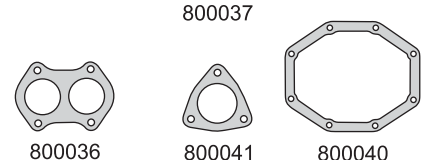

800036

800041

800040

FIAT IVECO



Motor/Engine	Cm³	HP	Ø
8210.02	13798	260	137

Fiat: Camión 619N1 - 697N TB
 Bus 391 - 691 - 319N
 Bus 221A 1970/...



DIESEL

Nº OE	Descripción/Description	Mat.		Ref.
	Jgo. juntas cañería bomba aceite	VS		800094
	Junta placa	CG	1	800096
	Bomba aceite	NB	1	800098
	Bomba aceite	NB	2	800099
	Arandela A 12 x 16 x 1 C	CU	2	
	Arandela A 6 x 10 x 1 C	CU	1	1
	Arandela A 8 x 13 x 1 C	CU	12	12
	Arandela bomba inyectora C 10 x 20 x 0.5 C	CU	6	6
	Arandela A 14 x 20 x 1.5 C	CU	10	10
	Arandela A 16 x 21 x 1 A	AL		3
	Arandela A 24 x 30 x 1.5 A	AL		2
	Arandela A 16 x 21 x 1.5 C	CU	6	6
	O´ring G 112 x 4	GS		3
	O´ring G 28.24 x 2.62	GS		2
	Kit de retenes completo			R800000
	Retén bancada 140 x 165 x 13	P	1	R800511P
	Retén distribución 70 x 90 x 15	P	1	R800012P
	Retén árbol de levas 25 x 40 x 8	N	1	R280415N

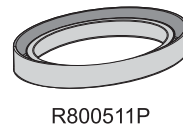
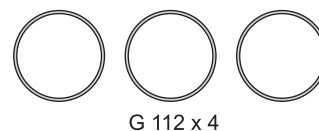
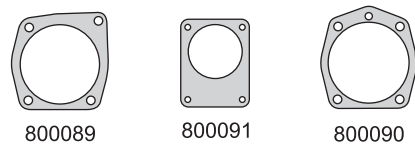
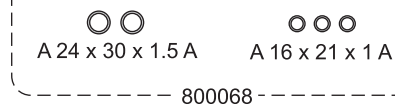
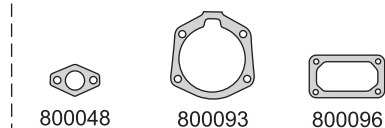
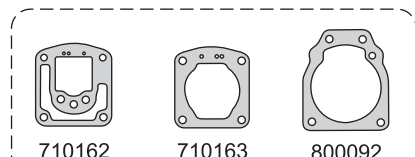
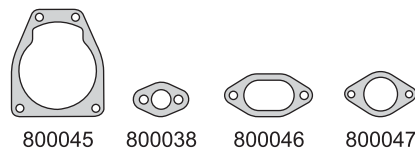
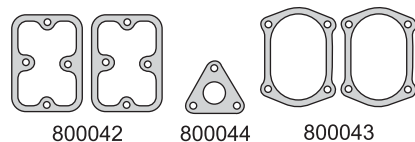

FIAT / IVECO

FIAT



Motor/Engine	Cm³	HP	Ø
682 N2 MK3	10676		125

Fiat: Camión 203



DIESEL

Nº OE	Descripción/Description	Mat.	Ref.
	Jgo. de juntas para motor		800100
758025	Junta tapa cilindros Ø 127 \pm 1.40	NFT 2	800105
968684	Junta tapa válvulas superior	CG 2	800110
	Jgo. junta para cárter (4)	CB 1	800111
1902214	Tapa distribución	CB 1	800112
	Placa distribución	CB 1	800113
	Tapa bomba de agua	CB 1	800114
968689	Jgo. múltiple escape (6)	NFT 1	800115
969035	Jgo. múltiple admisión (6)	NFT 1	800117
851774	Salida de escape	NFT 2	800118
852384	Bomba agua a block	CB 1	800119
889459	Tapa filtro aceite	CB 1	800127
889757	Tapa filtro aceite	CB 1	800129
889458	Base soporte bomba aceite	CB 1	800130
	Tubo aspiración	NB 1	800131
	Cuerpo termostato	NB 1	800132
	Base filtro aceite	CB 1	800133
	Cabecera cárter	CB 1	800134
	Cañería aspiración a tubo	NB 6	800135
858924	Junta tapa válvulas lateral	CG 2	800136
	Tubo colector agua (4)	NB 4	800137
	Cañería agua	NB 6	800138
	Tubo lubricación a bomba aceite	NB 1	800139
	Cañería agua	NB 1	800140
	Cañería agua	NB 1	800141
80142	Cañería agua	NB 1	800142
	Cañería agua	NB 1	800143
	Tapa inspección distribución	CB 1	800144

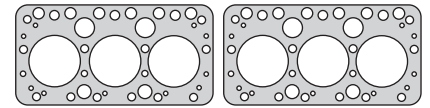

800105



800110

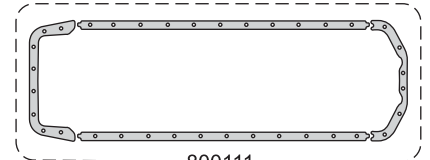

800111



800114

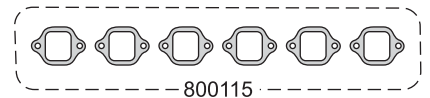

800115

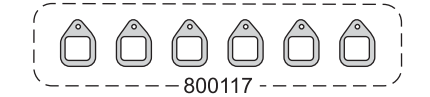

800117

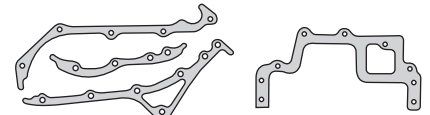

800112

800113

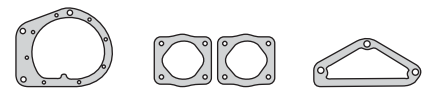

800114

800118

800119

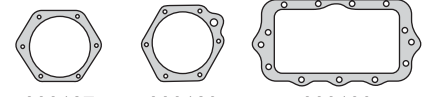

800127

800129

800130

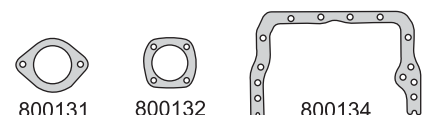

800131

800132

800134

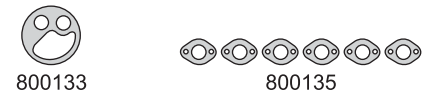

800133

800135



800138



800139

800137

800140

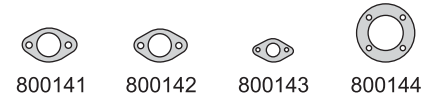

800141

800142

800143

800144

FIAT / IVECO

FIAT IVECO



Motor/Engine Cm³ HP Ø

221- 8210.01 12883 240 135

Fiat: Camión Bus 341A - 221 - 221H
619 NP 1965/66
693 N - N1 - T - T1 1965/68



DIESEL

Nº OE	Descripción/Description	Mat.	Ref.
	Jgo. de juntas para motor	●	800200-R
	Junta tapa cilindros Ø 137 \pm 1.40	NFT 2	800207
4654928/29	Jgo. de tornillos para tapas de cilindros		B800000
4530174	Junta tapa válvulas superior	NB 2	800010
4541081	Jgo. junta para cárter (3)	NB 1	800011
	Tapa distribución	NB 1	800212
	Placa distribución	CB 1	800213
4006034	Bomba de agua	NB 1	800014
	Jgo. múltiple escape (6)	NFT 1	800115
	Jgo. múltiple admisión (6)	NB 1	800017
4530835	Salida de escape	NFT 2	800018
4614887	Cuerpo termostato	NB 1	800032
4616568	Entrada y salida agua	NB 6	800033
	Junta	NB 1	800233
	Salida cañería agua	NB 2	800035
4617079	Tubería entrada agua	NB 20	800037
4632138	Cañería aceite a block	NB 1	800038
4511313	Compresor marelli	NB 1	800045
4606042	Entrada bomba agua	NB 1	800046
4575911	Cañería agua	NB 1	800047
	Jgo. reparación compresor marelli		800269
	Kit de retenes completo		R800000
	Retén bancada 140 x 165 x 13	P 1	R800511P
	Retén distribución 70 x 90 x 15	P 1	R800012P
	Retén árbol de levas 25 x 40 x 8	N 1	R280415N

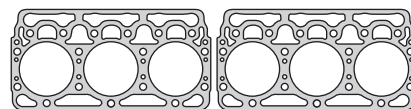

800207

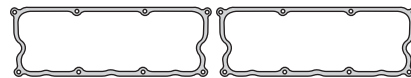

800010

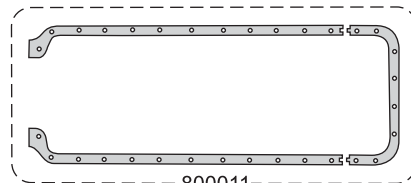

800011

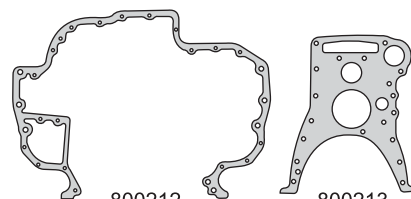

800212

800213

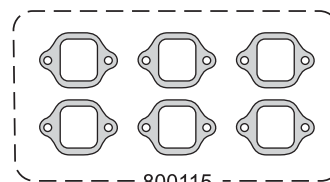

800115

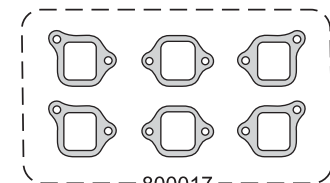

800017

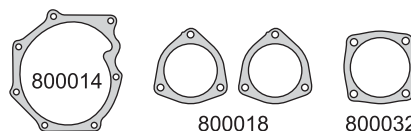

800014

800018

800032



800033

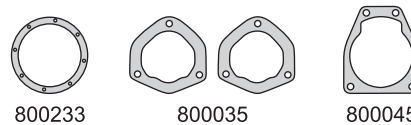

800233

800035

800045



800046

800038

800047

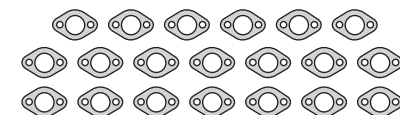

800037



R800511P



R800012P



R280415N

FIAT / IVECO

FIAT IVECO



Motor/Engine	Cm³	HP	Ø
8060.25	5861	177	104
8060.45/45S	5861	207	104

Iveco: Camión 150 N Turbo AU130
Eurocargo 150 E23 - 150 E20



DIESEL

Nº OE	Descripción/Description	Mat.	Ref.
1907934	Jgo. de juntas para motor		800300-R
1907832	Junta tapa cilindros Ø 105.3 \pm 1.70	NFT	1 800307
98427866	Junta tapa válvula	GS	1 800310
1902553	Jgo. junta para cárter (4)	NB	1 800311
98424045	Junta tapa distribución	NB	1 800312
98424046	Placa distribución	NB	1 800313
4599560	Tapa bomba de agua	NB	1 800314
98489690	Jgo. múltiple escape (6)	CHA	1 800315
4851921	Jgo. múltiple admisión (3)	NB	1 800317
4702409	Salida de escape	NFT	1 800018
98400779	Placa bomba de agua	NB	1 800319
4850986	Tapa anterior distribución	NB	1 800320
4653283	Tapa posterior distribución	NB	1 800321
1904985	Bomba hidráulica	NB	1 800322
4791332	Mando bomba inyectora	NB	1 800323
98418534	Tubo admisión	NB	1 800324
98400783	Base compresora	NB	1 800325
4851926	Base termostato	NB	1 800326
4851926	Codo termostato	NB	1 800327
4657434	Porta reten trasero	NB	1 800329
98400776	Base bomba agua	NB	1 800330
4848840	Codo termostato	NB	1 800331
4799060	Regulador bomba inyectora	NB	1 800332
4632138	Cañería agua	NB	2 800333
	Cuenta vueltas	NB	2 800334
98400786	Enfriador de aceite	NB	1 800335
4853970	Cañería aceite	NB	1 800336
4638370	Cañería aceite	NB	1 800337
	Caño de agua	NB	1 800338
	Retorno agua	NB	1 800339
	Retorno bomba de agua	NB	1 800340
4658663	Cuerpo bomba de agua	NB	1 800341
	Admisión turbo	NB	1 800342
541353	Junta base bomba inyectora	NB	1 310443
8583008	Turbina turbo	AC	1 800343
	Caño de agua	NB	1 800344
4769429	Mando bomba inyectora	NB	1 800345
	Bomba hidráulica	NB	1 800346
93161602/3	Acople trasero	NB	1 800347
98400783	Junta para cárter	NB	1 800348
619376	Entrada aceite	NB	1 800349
	Jgo. juntas caja de velocidades	VS	800350
93161602/1	Tapa pegada	NH	1 710162
93161602/2	Tapa de cilindro	NH	1 710163
98428396	Colector turbo	AC	1 350462
	Junta acople a distribución	NB	800092
93161602	Jgo. junta compresor Marelli (12)	VS	800368
	Junta tapa cilindros competición		800390
14457581	O'ring inyector G 25.12 x 1.78	GS	6
14457581	O'ring enfriador G 20.30 x 2.62	GS	2
14457681	O'ring caño bomba de aceite G 21.89 x 2.62	GS	4
17281981	O'ring enfriador G 18.72 x 2.62	GS	3
98465110	O'ring enfriador G 31.42 x 2.62	GS	2

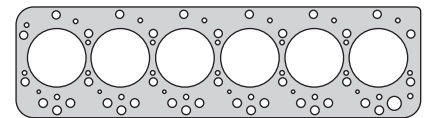

800307

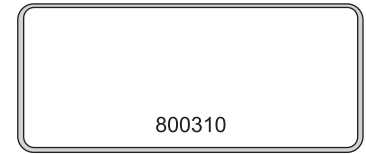

800310

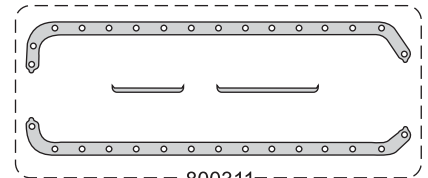

800311

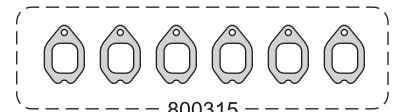

800315

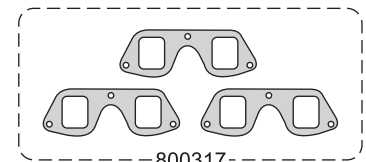

800317

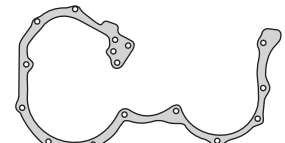

80312

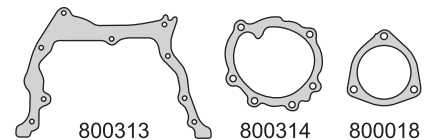

800313

800314

800018

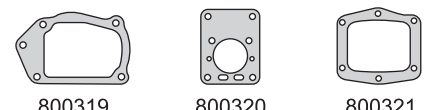

800319

800320

800321



800322

800323

800324



800325

800326

800327

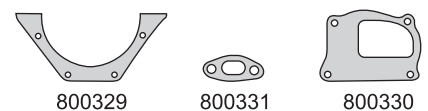

800329

800331

800330



800333

800332

800334



800335

800336

800337

FIAT IVECO



Motor/Engine	Cm³	HP	Ø
8060.25	5861	177	104
8060.45/45S	5861	207	104

Iveco: Camión 150 N Turbo AU130
Eurocargo 150 E23 - 150 E20



DIESEL

Nº OE	Descripción/Description	Mat.		Ref.
561293	O'ring bomba de aceite G 7.3 x 2.4	GS	1	
	Arandela A 16 x 20 x 1 A	AL	4	
	Arandela A 24 x 32 x 1.5 A	AL	2	
	Arandela A 18 x 22 x 1.5 C	CU	7	
	Arandela A 22 x 26 x 1.5 C	CU	6	
	Arandela C 10 x 20 x 0.5 C	CU	6	
99457401	Retén bancada 114 x 135 x 13	V	1	R800311V
99469265	Retén distribución 42 x 65 x 10	P	1	R800312P

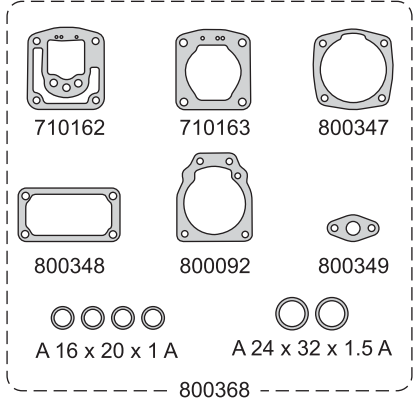
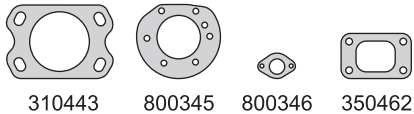
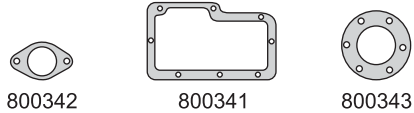
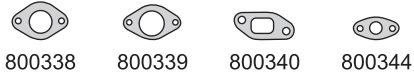

G 7.3 x 2.4

G 25.12 x 1.78

G 20.30 x 2.62 G 21.89 x 2.62

A 22 x 26 x 1.5 C

G 31.42 x 2.62 G 18.72 x 2.62

A 18 x 22 x 1.5 C

C 10 x 20 x 0.5 C

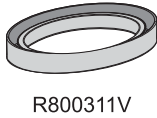

FIAT / IVECO

FIAT IVECO



Motor/Engine	Cm³	HP	Ø
8210.42L LE2	13798	370	137
8210.42K KE2	13798	420	137
8210.22.800	13798	310	137

Iveco: Euro Trakker - Euro Star - Euro Tech 89/...
180E42 - 190E31/E42/E36 - 240E42/E36
260E37/E42/E36 - 400E31/E37/E42
410E37/E42 - 440E37/E42
720E31 - 380E31 1991/...



DIESEL

Nº OE	Descripción/Description	Mat.	Ref.
0019088191	Jgo. de juntas para motor Jgo. de juntas superior		800500-R 800595
99465715	Jta. tapa cilindros Ø139 \pm 1.25	AC 2 2	800508
4769615/16	Jgo. de tornillos para tapa de cilindros		B800500
98480127	Junta tapa válvulas superior	NB 2 2	800010
4791426	Jgo. junta para cárter - 1er Tipo (3)	NB 1 1	800011
98493262	Junta para cárter - 2do Tipo	NB 1 1	800511
98476488	Junta tapa distribución - 1er Tipo	NB 1 1	800512
99450903	Junta tapa distribución - 2do Tipo	NB 1 1	800512-1
99431449	Placa distribución	NB 1 1	800513
99409494	Jgo. múltiple escape (6)	NFT 1 1	800515
99440847	Jgo. múltiple admisión (6)	NFT 1 1	800517
99440847/2	Jgo. múltiple admisión (6) 2do Tipo	NFT 1 1	800517-2
4530835	Salida de escape	NFT 2 2	800018
500308780	Entrada de agua a tapa de cilindros a block	NB 11 11	800537
	Guarnición goma	GS	800538
4863958	Tapa lateral motor	NB 1 1	800040
	Tubo refrigeración	NB 1 1	800540
	Tubo refrigeración	NB 1 1	800541
	Cuerpo respiración motor	NB 2 2	800542
	Tubo refrigeración	NB 1 1	800543
	Tromba de admisión	NB 1 1	800544
4863970	Radiador enfriador aceite	NB 1 1	800545
	Tubo refrigeración	NB 1 1	800546
4575911	Cañería agua	NB 4 4	800047
4852097	Tubo refrigeración	NB 4 4	800547
	Cañería aceite turbo	NB 1 1	800048
61318850	Tubo refrigeración	NB 1 1	800549
4512366	Escape turbo	AC 1 1	810163
	Tubo refrigeración	NB 1 1	800583
	Tubo refrigeración	NB 1 1	800584
61318823	Tubo refrigeración	NB 1 1	800586
98474309	Retorno de agua	NB 4 4	800587
99435380	Entrada de agua a tapa de cilindros	NB 4 4	800588
	Tubo refrigeración	NB 1 1	800589
	Bomba hidráulica	NB 1 1	800591
	Acople compresor Marelli - bicilindrico	NB 2 2	800592
	Bomba aceite	CB 1 1	800598
	Arandela A 40 x 48.5 x 1.5 C	CU 1 1	
	Arandela A 28 x 36 x 1.5 C	CU 1 1	
	Arandela A 24 x 30 x 1.5 C	CU 1 1	
	Arandela A 18 x 24 x 1.5 C	CU 2 2	
	Arandela A 16 x 22 x 1.5 C	CU 4 4	
	Arandela A 14 x 20 x 1.5 C	CU 9 9	
	Arandela A 14 x 20 x 1 C	CU 12 12	
	Arandela A 12 x 20 x 1.5 C	CU 10 10	
	Arandela A 12 x 17 x 1.5 C	CU 5 5	
	Arandela A 10 x 18 x 1 C	CU 2 2	
	Arandela A 10 x 16 x 0.5 C	CU 2 2	
	Arandela A 10 x 16 x 1 C	CU 6 6	
	Arandela A 8 x 14 x 0.5 C	CU 5 5	
	Arandela A 20 x 26 x 1.5 C	CU 3 3	
	O'ring G 246.30 x 6.99	GS 1 1	

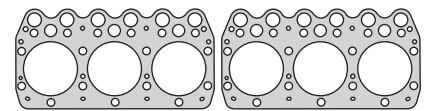

800508

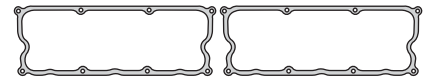

800010

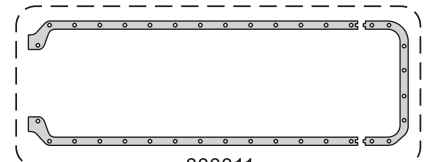

800011



800511

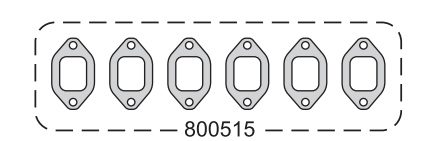

800515

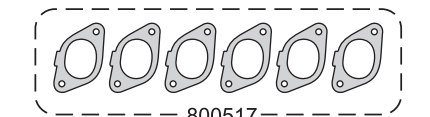

800517

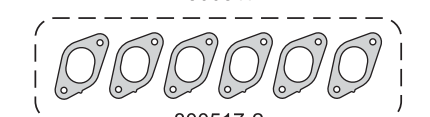

800517-2

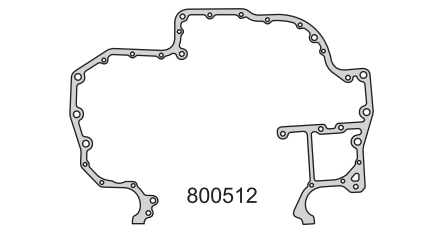

800512

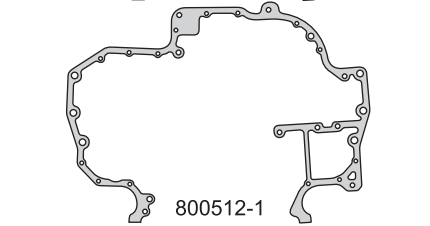

800512-1

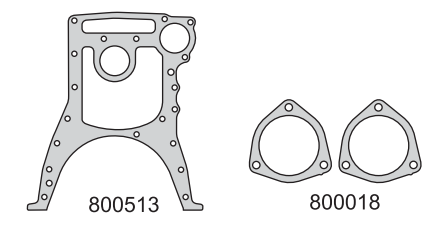

800513



800018

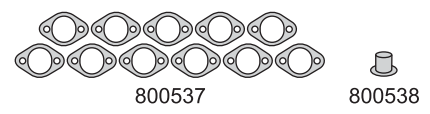

800537



800538

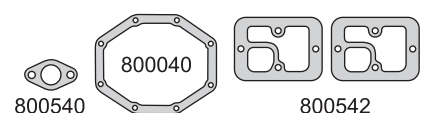

800040

800540

800542

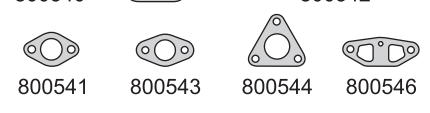

800541

800543

800544

800546

FIAT IVECO



Motor/Engine	Cm³	HP	Ø
8210.42L LE2	13798	370	137
8210.42K KE2	13798	420	137
8210.22.800	13798	310	137

Iveco: Euro Trakker - Euro Star - Euro Tech 89/...
 180E42 - 190E31/E42/E36 - 240E42/E36
 260E37/E42/E36 - 400E31/E37/E42
 410E37/E42 - 440E37/E42
 720E31 - 380E31 1991/...



DIESEL

Nº OE	Descripción/Description	Mat.	Ref.
	O´ring G 132.94 x 3.53	GS	1
	O´ring G 100 x 2	GS	1
	O´ring G 75.79 x 3.53	GS	1
	O´ring G 71.12 x 2.62	GS	1
	O´ring G 61.60 x 2.62	GS	1
	O´ring G 60 x 4	GS	2
	O´ring G 59.92 x 3.53	GS	1
	O´ring G 59.52 x 5.33	GS	4
	O´ring G 29.82 x 2.62	GS	2
	O´ring G 25.12 x 1.78	GS	12
	O´ring G 24.99 x 3.53	GS	8
	O´ring G 24.99 x 3.53	GS	4
	O´ring G 21.89 x 2.62	GS	1
	O´ring G 18.72 x 2.62	GS	1
	O´ring G 18.77 x 1.78	GS	6
	O´ring G 6.07 x 1.78	GS	2
	O´ring G 113.89 x 3.53	GS	1
	Kit de retenes completo		R800500
98494987	Retén bancada trasera 140 x 165 x 13	V	1 R800511V
98494984	Retén distribución 70 x 90 x 10	V	1 R270112V
98494989	Retén árbol de levas 45 x 75 x 10	V	1 R800513V

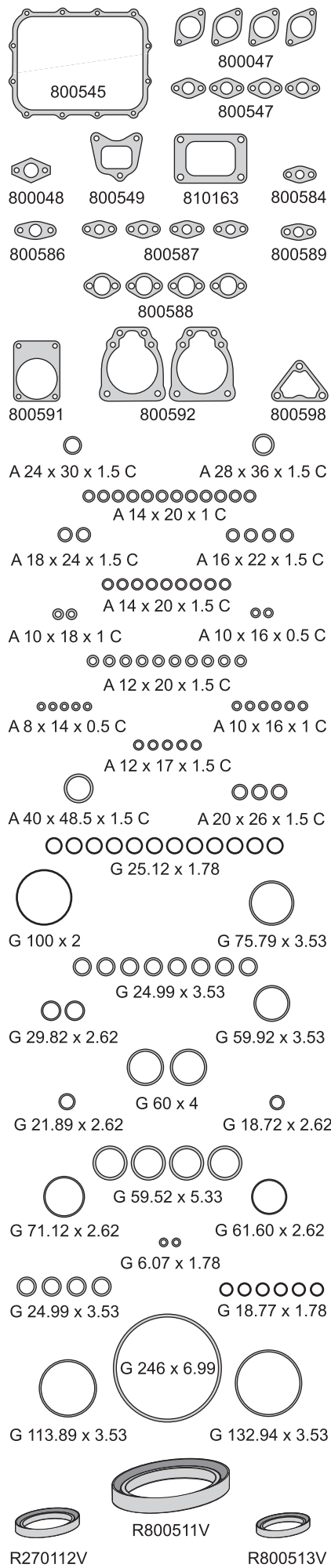

FIAT / IVECO

FIAT IVECO



Motor/Engine	Cm³	HP	Ø
8060.25	5861	143/177	104
8060.45/S	5861	207/277	104
Eurocargo			
DIESEL			

Iveco: 75/80/85/95/100/120/130/150/170
 E15 Turbo 1991/... - 80/85/100/120
 130/135/150/170 E18 Turbo 1991/...
 135/150/170/180/E23
 80/90/100/E21



Nº OE	Descripción/Description	Mat.	Ref.
1907853	Jgo. de juntas para motor		800600-R
	Junta tapa cilindros Ø 105.3 ± 1.70	NFT	1 800307
4845138	Junta tapa de válvulas	GS	1 800310
1907811	Jgo. juntas para cárter (4)	NH	1 800611
9842040	Junta tapa distribución 150	NB	1 800312
9842045	Junta tapa distribución eurocargo	NB	1 800612
98424046	Placa distribución 150	NB	1 800313
98424046	Placa distribución eurocargo	NB	1 800613
	Bomba de agua	NB	1 800614
98489690	Jgo. múltiple escape (6)	NFT	1 800616
4851921	Jgo. múltiple admisión - 150 (3)	NB	1 800317
4849995	Jgo. múltiple admisión - Eurocargo (3)	NB	1 800617
4842823	Placa bomba de agua	NB	1 800619
4850986	Tapa anterior distribución	NB	1 800320
4653283	Tapa posterior block	NB	1 800321
1904985	Bomba hidráulica	NB	1 800322
4791332	Mando bomba inyectora 150	NB	1 800323
4851926	Base termostato	NB	1 800326
4849994	Porta retén trasero cigueñal	NB	1 800629
4849996	Junta base bomba inyectora	NB	1 800630
	Junta caño aceite	NB	1 800631
	Junta retorno aceite	NB	1 800632
	Junta caño aceite	NB	1 800633
	Junta caño aceite turbo	NB	1 800634
4843348	Junta intercambiador aceite	NB	1 800635
500378359	Junta hidráulica eurobase	NB	1 800636
4638370	Cañería cierre	NB	1 800337
99445563	Junta base compresor	NB	1 800639
	Jgo. juntas turbo	AC	800640
	Junta tapa	NB	1 800641
4848525	Junta admisión euroturbo	NB	1 800642
8583008	Turbina turbo 150	AC	1 800343
	Junta conducto aceite	NB	1 800643
	Turbina turbo	AC	1 800644
4769429	Mando bomba inyectora	NB	1 800345
	Acople turbo	AC	1 800645
500378761	Junta base bomba de agua	NB	1 800646
	Junta inspección aire	NB	1 800647
4851923	Junta bomba inyectora	NB	1 800648
	Junta caño agua	NB	2 800649
4851004	Junta bomba hidráulica	NB	1 800655
	Retorno aceite turbo	NB	1 800656
3520140922	Colector a escape turbo	AC	1 350462
	O´ring G 79.69 x 3	GS	1
	O´ring G 66.27 x 3.53	GS	1
	O´ring G 63.09 x 3.53	GS	1
	O´ring G 61.60 x 2.62	GS	1
	O´ring G 53.57 x 3.53	GS	1
	O´ring G 45.36 x 3.53	GS	1
	O´ring G 44.12 x 2.62	GS	1
	O´ring G 43.82 x 5.33	GS	2
	O´ring G 37.77 x 2.62	GS	1
	O´ring G 31.42 x 2.62	GS	2

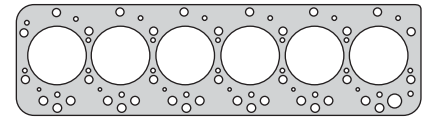

800307

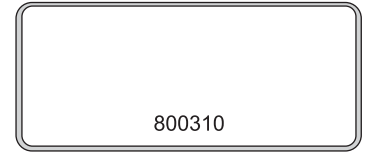

800310

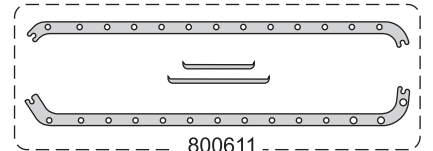

800611

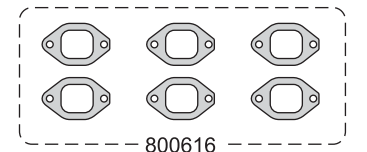

800616

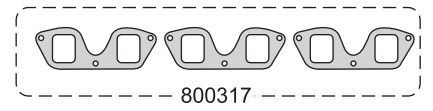

800317

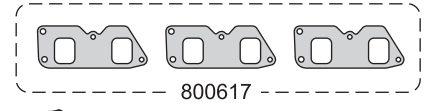

800617

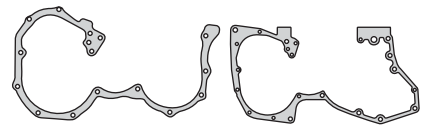

800312

800612

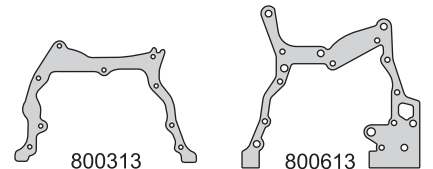

800313

800613

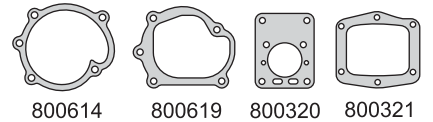

800614

800619

800320

800321

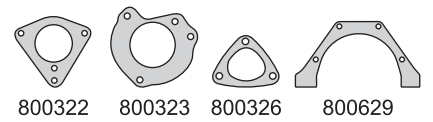

800322

800323

800326

800629

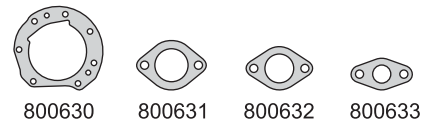

800630

800631

800632

800633

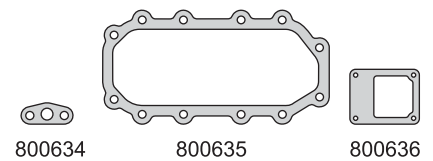

800634

800635

800636

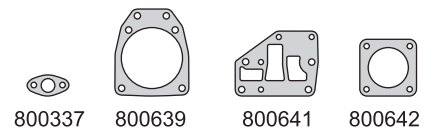

800337

800639

800641

800642

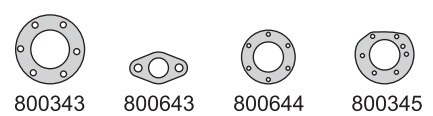

800343

800643

800644

800345

FIAT IVECO



Motor/Engine	Cm³	HP	Ø
8060.25	5861	143/177	104
8060.45/S	5861	207/277	104
Eurocargo			
DIESEL			

Iveco: 75/80/85/95/100/120/130/150/170
E15 Turbo 1991/... - 80/85/100/120
130/135/150/170 E18 Turbo 1991/...
135/150/170/180/E23
80/90/100/E21

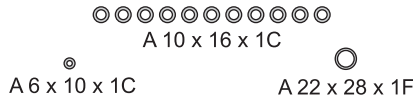
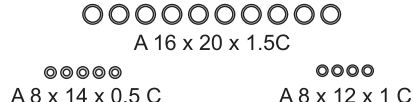
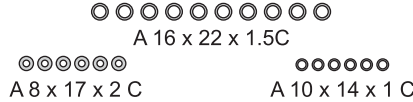
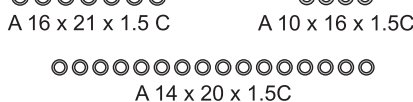
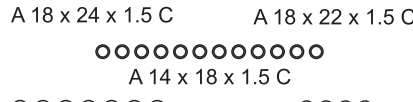
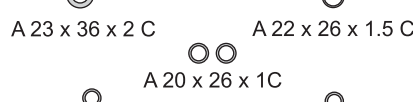
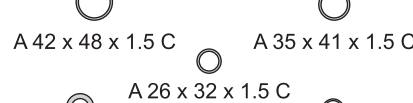
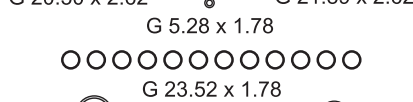
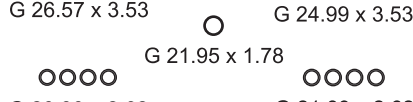
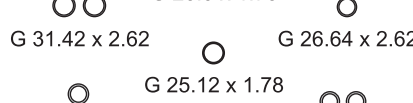
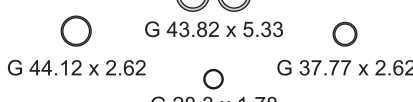
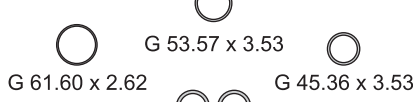
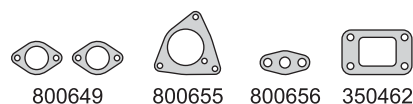
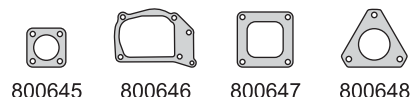

FIAT / IVECO

Nº OE	Descripción/Description	Mat.	Ref.
	O´ring G 28.3 x 1.78	GS	1
	O´ring G 26.64 x 2.62	GS	1
	O´ring G 26.57 x 3.53	GS	1
	O´ring G 25.12 x 1.78	GS	1
	O´ring G 24.99 x 3.53	GS	2
	O´ring G 23.52 x 1.78	GS	12
	O´ring G 21.89 x 2.62	GS	4
	O´ring G 21.95 x 1.78	GS	1
	O´ring G 20.30 x 2.62	GS	4
	O´ring G 5.28 x 1.78	GS	1
	Arandelas A 42 x 48 x 1.5 C	CU	1
	Arandelas A 35 x 41 x 1.5 C	CU	1
	Arandelas A 23 x 36 x 2 C	CU	1
	Arandelas A 26 x 32 x 1.5 C	CU	1
	Arandelas A 20 x 26 x 1 C	CU	2
	Arandelas A 22 x 26 x 1.5 C	CU	1
	Arandelas A 18 x 24 x 1.5 C	CU	1
	Arandelas A 18 x 22 x 1.5 C	CU	1
	Arandelas A 16 x 21 x 1.5 C	CU	7
	Arandelas A 16 x 22 x 1.5 C	CU	10
	Arandelas A 16 x 20 x 1.5 C	CU	10
	Arandelas A 14 x 20 X 1.5 C	CU	16
	Arandelas A 14 x 18 X 1.5 C	CU	12
	Arandelas A 12 x 18 X 1 C	CU	10
	Arandelas A 12 x 18 x 1.5 C	CU	7
	Arandelas A 10 x 16 x 1.5 C	CU	4
	Arandelas A 10 x 16 x 1 C	CU	11
	Arandelas A 12 x 17 x 1.5 C	CU	10
	Arandelas A 8 x 17 x 2 C	CU	6
	Arandelas A 10 x 14 x 1 C	CU	6
	Arandelas A 8 x 14 x 0.5 C	CU	5
	Arandelas A 8 x 12 x 1 C	CU	4
	Arandelas A 6 x 10 x 1 C	CU	1
	Arandelas A 5 x 8 x 1 C	CU	3
	Arandelas A 22 x 28 x 1 F	F	1
98488393	Retén distribución 42 x 65 x 10	V	1 R800312V
98488395	Retén bancada 114 x 135 x 13	V	1 R800311V

FIAT IVECO



Motor/Engine	Cm³	HP	Ø
170E22 F4AE0681D ISBe 6 24V TDI - EDC	5880	180/210	102
	5883	275	102

Cummins: ISB 2004/...
Iveco: Eurocargo 80 E18 - 80 E21 - 90 E18
 90 E21 Tector - Common Rail Turbo
 Intercooler EDC 130 E18
 120 E24/E28
 150 E18 2004/...



DIESEL

Nº OE	Descripción/Description	Mat.	Ref.
2995642	Jgo. de juntas para motor		800800-R
	Jgo. de juntas superior		800895
2830704	Junta tapa cilin. Ø 105 ± 1.20	MLS	1 1 800808
4891025-L14	Jgo. de tornillos para tapa de cilindros	AC	B800800
504070038	Junta tapa válvulas superior	GS	1 1 800810
504070040	Junta tapa válvulas inferior	GS	1 1 800836
4897861	Junta para cárter	GS	1 1 800811
50406856	Anillo goma bomba de agua G 88 x 99 x 5	GS	1 1 800814
2830444	Jgo. múltiple escape (6)	GFT	1 1 800816
4895121	Anillo de goma G 50 x 60 x 5	GS	800819
4899239	Guarnición tapa de válvulas	GS	6 6 870533
4886408	Junta enfriador aceite tapa	NFT	800834
4896409	Junta enfriador aceite placa	NFT	1 800835
4896811	Guarnición central eléctrica	GS	1 800837
4894510	Junta entrada turbo	AC	1 1 800838
4842146	Guarnición llenado aceite	GS	1 1 800839
50403096	Guarnición termostato	GS	1 1 260039
4891288	Junta salida aceite turbo	NB	1 800840
4898301	Junta chupador aceite	NB	1 800841
4899584	Junta salida escape turbo	SLS	1 1 800844
4895132	Junta escape turbo	AC	1 1 350462
	Juego turbo (4)	VS	1 800868
4830926	O´ring inyector G 21 x 3	GS	3 3 800842
4893741	Arandela pico inyector A 8 x 15 x 1.5 C	CU	6 6 800843
	Arandela A 12.5 x 17 x 1.5 C	CU	6
	Arandela A 18 x 22 x 1 C	CU	1
00R0P004	Arandela A 6 x 9 x 1 A	AC	1
	Anillo de goma G 105 x 111 x 3.65	GS	1
4830926	O´ring G 21.82 x 3.53	GS	1
	O´ring G 13.94 x 2.62	GS	2
	O´ring G 11 x 3	GS	6
	O´ring G 75.87 x 2.62	GS	1
	O´ring G 59.99 x 2.62	GS	1
	O´ring G 44 x 3	GS	1
	O´ring G 23.47 x 2.62	GS	1
	O´ring G 23.52 x 1.78	GS	2
	O´ring G 20.30 x 2.62	GS	1
	O´ring G 18.72 x 2.62	GS	1
	O´ring G 17.12 x 2.62	GS	2
	O´ring G 15.6 x 1.78	GS	2
	O´ring G 10.82 x 1.78	GS	1
	O´ring G 10.77 x 2.62	GS	1
	O´ring G 9.19 x 2.62	GS	1
	O´ring G 9.25 x 1.78	GS	1
	O´ring G 8 x 2.40	GS	12
	O´ring G 8 x 1.50	GS	2
	Kit de retenes completo		R800800
4895872/411	Jgo. retén válvulas (24)	V	1 R800810V
4890833	Retén bancada 130 x 155 x 12,5/16	T	1 R800811T
4890832	Retén distribución 70 x 100 x 12,5/16	T	1 R800812T

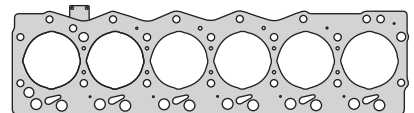

800808

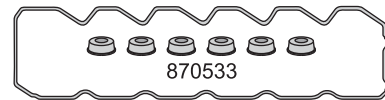

870533

800810



800836

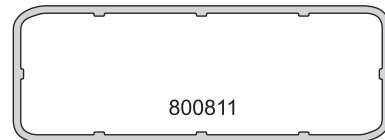

800811

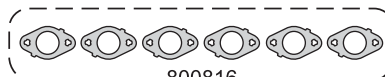

800816



800814

800819

800839

260039

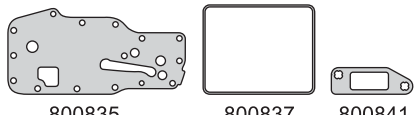

800835

800837

800841

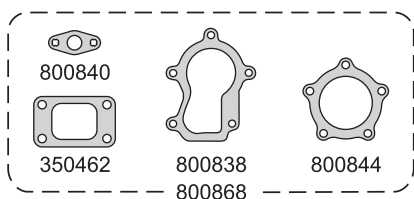

800840

800838

800844

350462

800868

800844



A 8 x 15 x 1.5 C

A 12.5 x 17 x 1.5 C

A 18 x 22 x 1 C

G 11 x 3

G 13.94 x 2.62

G 75.87 x 2.62

G 59.99 x 2.62

G 44 x 3

G 17.12 x 2.62

G 20.3 x 2.62

G 21 x 3

G 21.82 x 3.53

G 23.52 x 1.78

G 23.47 x 2.62

G 9.25 x 1.78

G 15.6 x 1.78

G 18.72 x 2.62

G 8 x 2.40

G 10.82 x 1.78

G 10.77 x 2.62

A 6 x 9 x 1 A



R800811T



R800812T

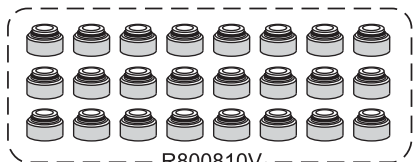

R800810V

FIAT IVECO



Motor/Engine	Cm³	HP	Ø
F2BE0681 F2BE3681 E4 Turbo Intercooler	8000	310	115

Iveco: Cursor 8 Eurotech (E24/E31/E35)
Eurotrakker (E24/E27/E31/E35/T27/T31
T33/T35/T36) - Stralis (S27/S30/S31/S33
S35-S36) - Euromover (E24)
Cavallino 2007/...



DIESEL

Nº OE	Descripción/Description	Mat.	1	2	Ref.
	Jgo. de juntas para motor				800900-R
	Jgo. de juntas superior		●	●	800995
500382172	Junta tapa cilin. Ø 127.5 ± 1.50	MLS	1	1	800908
500354580	Jgo. de tornillos para tapa de cilindros				B800900
99446692	Junta tapa válvulas	GS	1	1	800910
99443902	Junta para cárter	GS		1	800911
500383038	Junta distribución	GS		1	800912
504154202	Jgo. múltiple escape (6)	GF	1	1	800916
504026624	Junta plano admisión	AC	2	2	800917
500301732	Salida de escape	AC	1	1	800918
504043725	Junta termostato	SLS	1	1	800919
500383043	Junta respiradero motor	GS		2	800920
504045791	Junta plano motor	SLS		1	800926
504045796	Junta enfriador de aceite	SLS		1	800938
99450932	Junta soporte frente de motor	SLS		1	800939
504013562	Junta base filtro de aceite	SLS		1	800940
	Junta	SLS		1	800941
	Junta	SLS		1	800942
	Junta brida	SLS		1	800943
	Junta brida	SLS		1	800944
	Junta	SLS		1	800945
98451118	Junta entrada turbo a escape	AC	1	1	880263
504164259	Jgo. o´ring inyector (18)	GS		1	800946
	O´ring inyector G 30 x 2.5	V		6	
	O´ring inyector G 26.5 x 2.5	S		6	
	O´ring inyector G 29 x 2.3	P		6	
	Arandela con inserto A 36.5 x 53 x 3.5	AC/GS		1	
	Arandela con inserto A 31.5 x 46 x 2	AC/GS		3	
	Arandela con inserto A 27.5 x 41.5 x 3	AC/GS		1	
	Arandela con inserto A 26 x 39 x 2	AC/GS		3	
	Arandela con inserto A 20.5 x 32 x 3	AC/GS		1	
	Arandela con inserto A 17 x 28 x 2	AC/GS		3	
	Arandela con inserto A 15 x 26 x 2	AC/GS		7	
	Arandela con inserto A 13.5 x 24 x 1.5	AC/GS		31	
	Arandela con inserto A 11.5 x 22 x 2	AC/GS		7	
	Arandela con inserto A 8 x 18 x 2	AC/GS		1	
	Arandela con inserto A 6.5 x 14 x 1.5	AC/GS		4	
	Arandela con inserto A 6.5 x 13 x 1.5	AC/GS		2	
	O´ring G 130 x 3.3	P		2	
	O´ring G 127 x 3.4	P		1	
	O´ring G 120 x 3.4	S		18	
	O´ring G 110 x 3.4	P		1	
	O´ring G 62 x 3	S		1	
	O´ring G 57 x 3.5	P		1	
	O´ring G 48 x 3	P		1	
	O´ring G 45 x 2.5	P		1	
	O´ring G 39 x 3	P		1	
	O´ring G 35 x 3.5	S		1	
	O´ring G 25 x 3.3	S		1	
	O´ring G 24 x 1.8	P		12	
	O´ring G 22 x 2.5	P		1	
	O´ring G 10 x 2.5	P		1	
	Kit de retenes completo				R800900

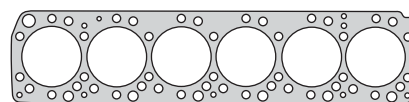

800908

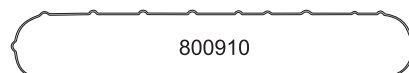

800910

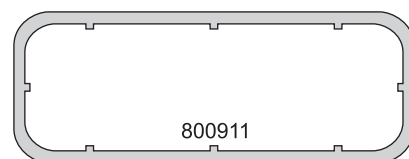

800911

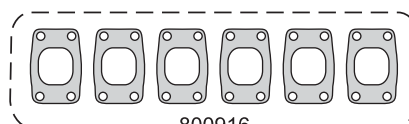

800916

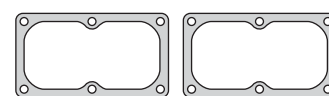

800917

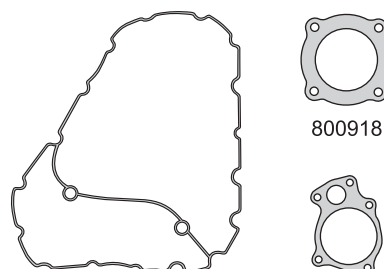

800912

800918

800919

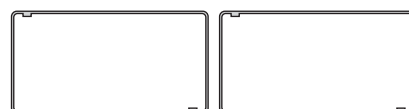

800920

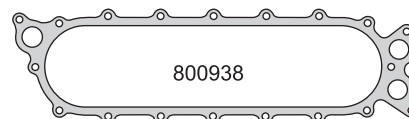

800938

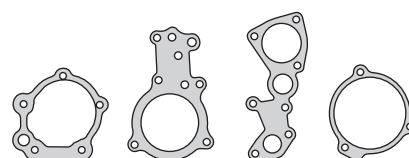

800926

800939

800940

800941

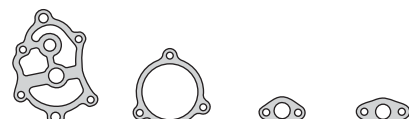

800942

800943

800944

800945

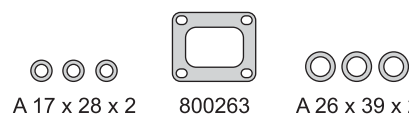

800263

A 17 x 28 x 2

A 26 x 39 x 2



A 36.5 x 53 x 3.5



A 27.5 x 41.5 x 3

A 31.5 x 46 x 2

FIAT IVECO



Motor/Engine	Cm³	HP	Ø
F2BE0681 F2BE3681 E4 Turbo Intercooler	8000	310	115

Iveco: Cursor 8 Eurotech (E24/E31/E35)
Eurotrakker (E24/E27/E31/E35/T27/T31
T33/T35/T36) - Stralis (S27/S30/S31/S33
S35-S36) - Euromover (E24)
Cavallino 2007/...



DIESEL

Nº OE	Descripción/Description	Mat.	Ref.
4895872/411	Jgo. retén válvulas (24)	V	1 R800910V
99447291	Retén bancada 112 x 147 x 13.65	V	1 R800911V
99447290	Retén distribución 88 x 123 x 13.65	V	1 R800912V
	Retén auxiliar 35 x 44 x 6.2	V	1 R800913V

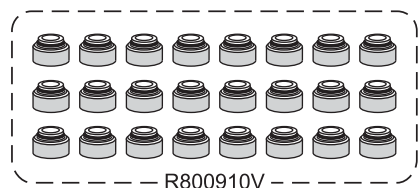
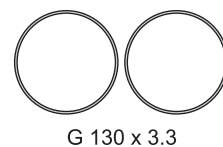
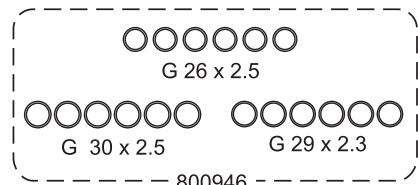
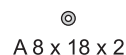
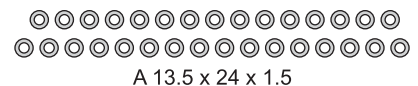
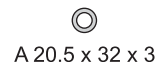

FIAT / IVECO

FIAT IVECO



Motor/Engine **Cm³** **HP** **Ø**

F3BE3681A **13000** **380/420** **135**

Turbo Intercooler

Iveco: Cursor 13 - Euro Stard 260E48 - 440E46
440E48 - Stralis 260/440S44-190/260
440S48/260/440S50/54/56 - Eurotrakker
190/260/340/380E38/E44
400/410/440/720E38/E44



DIESEL

Nº OE	Descripción/Description	Mat.	Ref.
	Jgo. de juntas para motor		801000-R
	Jgo. de juntas superior	●	801095
504007514	Jta. tapa cilindros Ø 151 ± 1.44	MLS	1 1 801008
	Junta tapa de válvulas	GS	1 1 801010
504024777	Junta para cárter	GS	1 1 801011
500382999	Junta tapa distribución	GS	1 1 801012
500383189	Junta placa distribución	SLS	1 1 801013
99043768	Jgo. múltiple escape (6)	GFT	1 1 801016
504026624	Junta plano admisión	AC	2 2 801017
500362150	Junta carcasa termostato	SLS	1 1 801019
500383043	Junta respiradero motor	GS	2 2 801020
500398649	Junta filtro aire respiradero motor	GS	1 1 801021
99448739	Junta plano árbol levas a engranaje	SLS	1 1 801026
99452273	Junta tapa bomba aceite	SLS	1 1 801027
500343518	Junta chupador bomba aceite	SLS	1 1 801029
504045796	Junta empalme refrigerador aceite	SLS	1 1 801030
504015752	Junta acople filtros aceite	SLS	1 1 801032
99460940	Junta codo bomba de agua	SLS	1 1 801033
	Junta	SLS	1 1 801034
98412509	Junta retorno aceite turbo	SLS	1 1 801035
504045796	Junta enfriador aceite	SLS	1 800938
	Junta carga aceite	GS	1 1 801040
500379769	Jgo. o´ring inyector (18)	GS	1 1 801046
500387050	Junta salida turbo	AC	1 1 810362
99458095	Junta entrada turbo	AC	1 1 810363
	Arandelas con inserto A 41 x 53 x 3	AC/GS	1
	Arandelas con inserto A 35 x 46 x 2	AC/GS	3
	Arandelas con inserto A 30 x 39 x 2	AC/GS	3
	Arandelas con inserto A 23 x 32 x 2.5	AC/GS	1
	Arandelas con inserto A 20 x 28 x 2	AC/GS	6
	Arandelas con inserto A 18 x 22 x 2	AC/GS	26
	Arandelas con inserto A 14 x 22 x 2	AC/GS	7
	Arandelas con inserto A 10 x 18 x 2	AC/GS	2
	Arandelas con inserto A 8 x 14 x 1.5	AC/GS	4
	O´ring G 143 x 3.5	GS	18
	O´ring G 128.5 x 3.3	GS	3
	O´ring G 120 x 3.5	GS	1
	O´ring G 47 x 3	GS	1
	O´ring G 45 x 2.5	GS	2
	O´ring G 37.5 x 3.5	GS	1
	O´ring G 29 x 3.5	GS	1
	O´ring porta inyector G 27 x 1.7	GS	12
	O´ring G 12 x 2.5	GS	1
	Kit de retenes completo		R801000
40101874	Jgo. retén válvulas (12)	V	1 R801010V
40102693	Retén bancada 130 x 160 x 13.5	S	1 R801011S
40102683	Retén distribución 100 x 130 x 13	S	1 R801012S
	Retén auxiliar fijación 34 x 43.8 x 6	P	2 R801015P

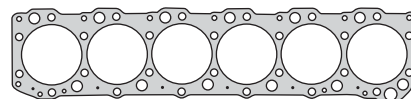

801008

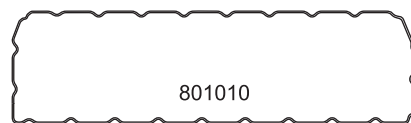

801010

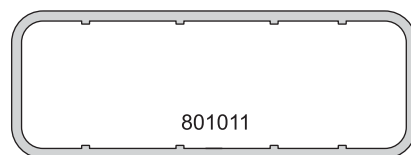

801011

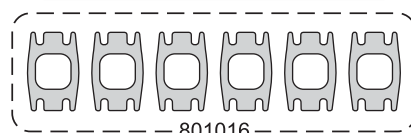

801012

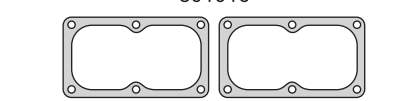

801013



801016

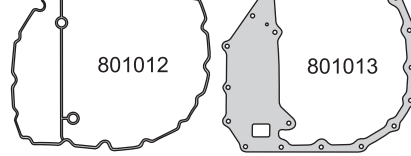

801017

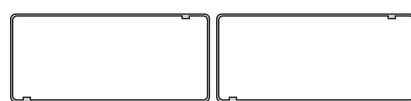

801019

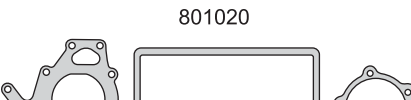

801020

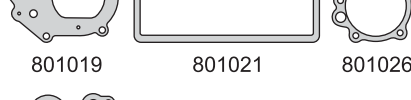

801021



801026

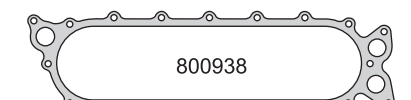

801027



801029

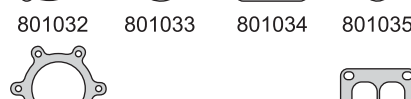

801030



801032

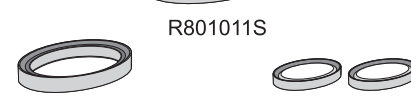

801033

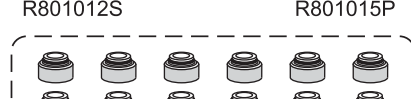

801034

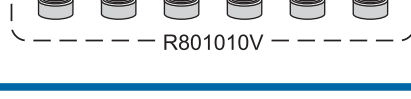

801035



800938

801046

810362

810363

801011S

801012S

801015P

801010V

FIAT / IVECO

FORD



Motor/Engine	Cm³	HP	Ø
BSD 332 - 333/H	3294	81	111.8

Ford: Tractor 4600 - 4110 - 4140 - 4190 - 4200
4400 - 4410 1965/74
4610 - 4610H - 4610SU 1981/90



DIESEL

Nº OE	Descripción/Description	Mat.	Ref.
	Jgo. de juntas para motor		330000
	Jgo. de juntas superior		330095
D3NN-6051G	Jta. tapa cilindros Ø114.5 ± 1.50	NFT	1 1 330007
C7NN-6548B	Junta tapa válvulas	CG	1 1 330010
D0NN-6710A	Junta para cárter	NB	1 1 330011
C5NE-6020A	Tapa distribución	NB	1 1 330012
C5NE-60045A	Placa distribución	NB	1 1 330013
D6NN-8513A	Tapa bomba de agua	NB	1 1 330014
C5NE-9448A	Múltiple escape	NFT	1 1 330016
D3NN-9439A	Múltiple admisión	NB	1 1 330017
D6NN-8507A	Placa bomba de agua	NB	1 1 330019
CEDE-8255A	Conexión salida de agua	NB	1 1 330119
C5NE-9F598A	Inspección distribución	NB	1 1 330029
C7NN-6659A	Bomba aceite a block	NB	1 1 330030
D0NN-H918A	Carcasa termostato	NB	1 1 330031
C5NE-9F596A	Protector inyector	CG	3 3 330032
D3NN0-9439A	Entre colectores	NB	1 1 330034
C7NN-6N008B	Tapa trasera motor	CG	1 1 330036
C5HN6N305C	Junta	CG	1 1 330037
	Válvula termostato	NB	1 1 330038
C5NE-9F585-A	Bomba inyectora	NB	1 1 330046
D3NN-6336-A	Jgo. empaquetadura lateral cigüeñal (2)	SNA	1 1 330058
C5NE-9E529-A	Arandela inyector A 10 x 16 x 1 C	CU	4 4
	Arandela A 24 x 30 x 2.5 A	AL	1 1
	Arandela A 8 x 12 x 1 C	CU	8 8
	Arandela A 19 x 25 x 1 A	AL	1 1
87095594	O'ring G 136 x 3.5	GS	1 1
379275594	O'ring G 82 x 2.5	GS	1 1
	O'ring G 56 x 4	GS	3 3
	O'ring G 20 x 4	GS	1
	O'ring G 7 x 11 x 2	GS	3 3
	Kit de retenes completo		R330000
	Jgo. retén válvulas (6)	P	1 1 R330010P
	Retén bancada 122.2 x 140.8 x 12	P	R330011P
	Retén distribución 60.3 x 82.5 x 11	P	R330012P

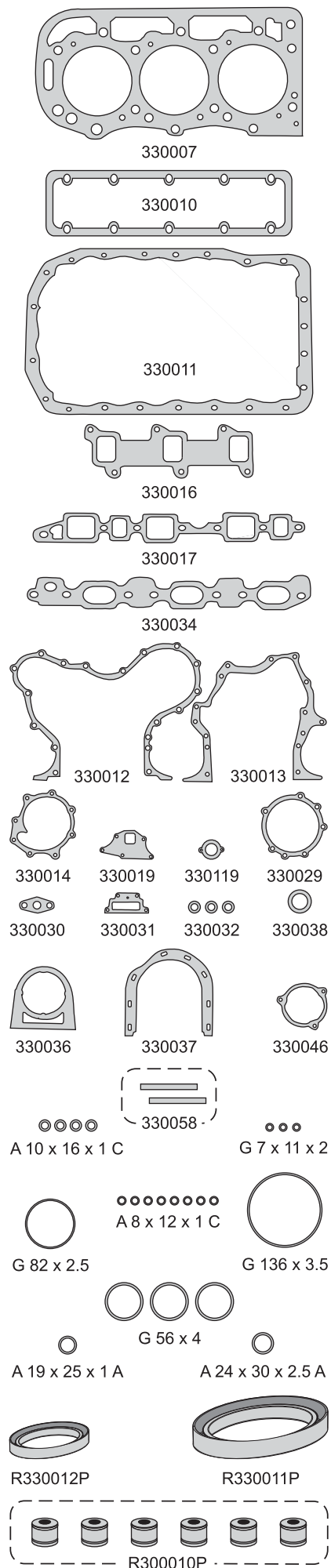

FORD

FORD



Motor/Engine	Cm³	HP	Ø
BSD 442 - 256	4196	72	111.8
BSD 444	4385	80	111.8
BSD 444T	4392	82	111.8
268	4393	82/87	111.8

Ford: Tractor 5610 - 5030 - 5110 - 5610 - 5900
 6600 - 6700 - 7000 - 7100 - 7200 72HP
 6410 - 6610 - 6710 - 7600 - 7700 80HP
 6810 - 7410 - 7610 - 7710 82HP
 F2000- F4000 - FB4000 87HP
 Tractor 6600/6610 87HP



DIESEL

Nº OE	Descripción/Description	Mat.	Ref.
	Jgo. de juntas para motor		330100
	Jgo. de juntas superior		330195
D3NN-6051H	Jta. tapa cilindros Ø114.5 ±1.50	NFT	1 1 330107
C7NN-6584C	Junta tapa válvulas	CG	1 1 330110
D4NN-6710A	Junta para cárter	NB	1 1 330111
C5NE-6020A	Tapa distribución	NB	1 330012
C5NE-60045A	Placa distribución	NB	1 330013
D6NN-8513A	Tapa bomba de agua	NB	1 330014
C5NE-9448B	Múltiple escape	NFT	1 1 330116
	Múltiple admisión	NB	1 1 330117
D6NN-8507A	Placa bomba de agua	NB	1 330019
CEDE-8255A	Conexión salida de agua	NB	1 330119
C5NE-9F598A	Inspección distribución	NB	1 330029
C7NN-6659A	Bomba aceite a block	NB	1 330030
D0NN-H918A	Carcasa termostato	NB	1 330031
C5NE-9F596A	Protector inyector	CG	4 4 330032
D3NN0-9439B	Entre colectores	NB	1 1 330134
	Colector admisión	NB	1 1 330135
C7NN-6N008B	Tapa trasera motor	CG	1 330036
C5HN6N305C	Junta	CG	1 330037
	Válvula termostato	NB	1 330038
C5NE-9F585-A	Bomba inyectora	NB	1 330046
D3NN-6336-A	Jgo. empaquetadura lateral cigüeñal (2)	SLA	1 330058
C5NE-9E529-A	Arandela inyector A 9.6 x 17 x 1.5 C	CU	
	Arandela A 24 x 30 x 2.5 A	AL	1 1
	Arandela A 19 x 25 x 1 A	AL	1 1
	Arandela A 8 x 12 x 1 C	CU	8 8
	Arandela A 10 x 16 x 1 C	CU	4 4
87095594	O'ring G 136 x 3.5	GS	1 1
379275594	O'ring G 82 x 2.5	GS	1 1
	O'ring G 56.5 x 4	GS	1 1
	O'ring G 20 x 4	GS	1 1
	O'ring G 7 x 11 x 2	GS	4 4
	Kit de retenes completo		R330100
	Jgo. retén válvulas (8)	P	1 1 R330110P
	Retén bancada 122.2 x 140.8 x 12	P	R330011P
	Retén distribución 60.3 x 82.5 x 11	P	R330012P

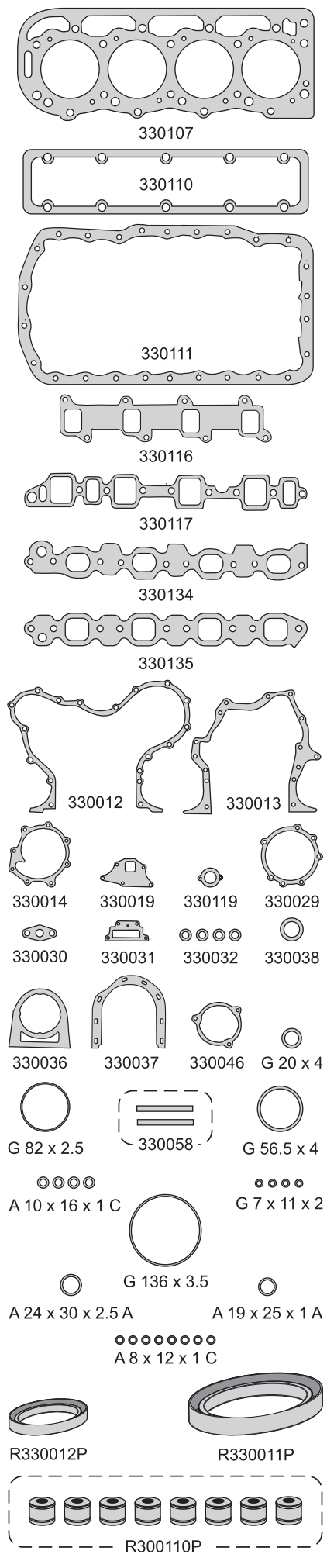

FORD

FORD



Motor/Engine	Cm³	HP	Ø
Fase I-II Cargo 6.6/7.8 Simples/Turbo	6572	110	111.8

Ford: 7810 - 7910 - 8210 - 8530 1988/...
8630 - 8750 - 8830 1992/...
Fase I-II - Cargo 6.6/7.8 Simples/Turbo



DIESEL

Nº OE	Descripción/Description	Mat.	Ref.
	Jgo. de juntas para motor		● 330200-R
ETHN-6051AA	Junta tapa cilindros Ø 114.5 ± 1.50	NFT	1 330207
E5HN-6584AA	Junta tapa válvulas		1 330210
E3HN-6710AA	Junta para cárter		1 330211
E5HN-6020AB	Tapa distribución		1 330212
E5HN6N645AB	Placa distribución	NH	1 330013
E3HN-6020AA	Tapa distribución		1 330213
E5HN-8507AA	Bomba de agua		1 330214
E5HN-9448AB	Jgo. múltiple escape (2)		1 330215
C5NE-9448A	Jgo. múltiple escape (2)		1 330216
E5HN-9439AA	Múltiple admisión		1 330217
E5HN-8255AA	Salida de agua		1 330219
E5HN-9L437AC	Conexión admisión		1 330220
E6NN-6N653AB	Pasaje aceite		1 330230
64HN-6N652AB	Pasaje aceite turbo		1 330231
E3HN-9439AA	Entre colector admisión		1 330234
E5HN-6N305C	Tapa placa	CG	1 330037
	Junta		1 330263
E5HN-6N640AA	Entrada turbina	AC	1 810363
	Arandela A 24.8 x 19.6 x 2 N	N	1
	Arandela A 17.9 x 9.5 x 1.5 C	CU	6
	Arandela A 9.9 x 6.3 x 0.83 C	CU	12
	O'ring G 7.65 x 1.78	GS	2
	O'ring G 10.82 x 1.78	GS	8
	O'ring G 17.17 x 1.78	GS	6
	O'ring G 21.82 x 3.53	GS	3
	O'ring G 26.57 x 3.53	GS	3
	O'ring G 23.47 x 2.90	GS	1
	O'ring G 32.92 x 3.53	GS	1
	O'ring G 38 x 3.40	GS	3
	O'ring G 55.25 x 2.50	GS	1
	O'ring G 44.12 x 2.62	GS	1
	O'ring G 82.22 x 2.62	GS	1
	Kit de retenes completo		R330200
	Jgo. retén válvulas (12)	P	1 R330210P
	Retén bancada 122.2 x 140.8 x 12	P	1 R330011P
	Retén distribución 66.7 x 88.89 x 11/12.5	P	1 R330212P

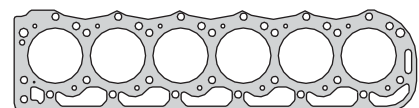

330207

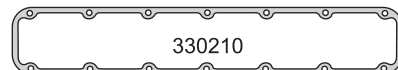

330210



330211

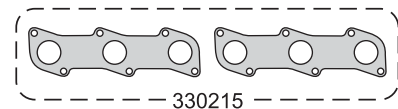

330212

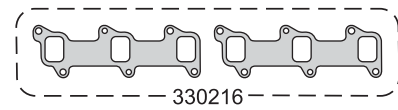

330214

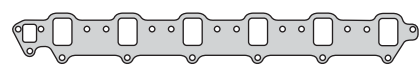

330215

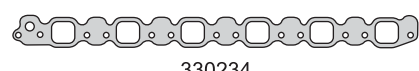

330216



330219

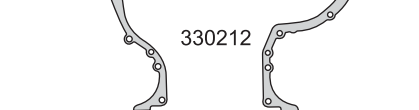

330220



330230



330231



330234



330037



810363



330213 330013

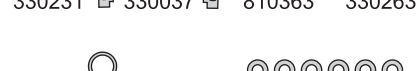

330214 330219 330220 330230



330231 330037 810363 330263

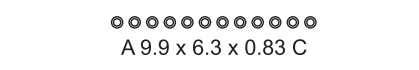

A 24.8 x 19.6 x 2 N



A 17.9 x 9.5 x 1.5 C



A 9.9 x 6.3 x 0.83 C

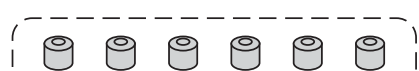

R330212P R330011P



R330210P

FORD



taranto

Luego de meses de investigación y ensayos en motores hemos logrado esta nueva versión de junta combinando la sellabilidad de materiales fibrosos y el cierre de cámara de combustión de juntas Multiláminas (MLS).

NUEVA TECNOLOGIA



Aro de fuego de acero sólido 4 mm. de apoyo en zona crítica.

✓ Mayor coeficiente de disipación térmica

— Aro de fuego solapado.
Junta de baja resistencia térmica.



Nueva Tecnología Taranto.

Las juntas están diseñadas para superar las exigencias de presión y temperatura que producen los motores de última generación.

- Micro y macro sellado en zonas críticas.
- Compensa los espesores rectificadas, con el objetivo de no alterar la relación de compresión.
- Aro de fuego de acero sólido que garantiza el excelente sellado de la cámara de combustión en las zonas críticas.

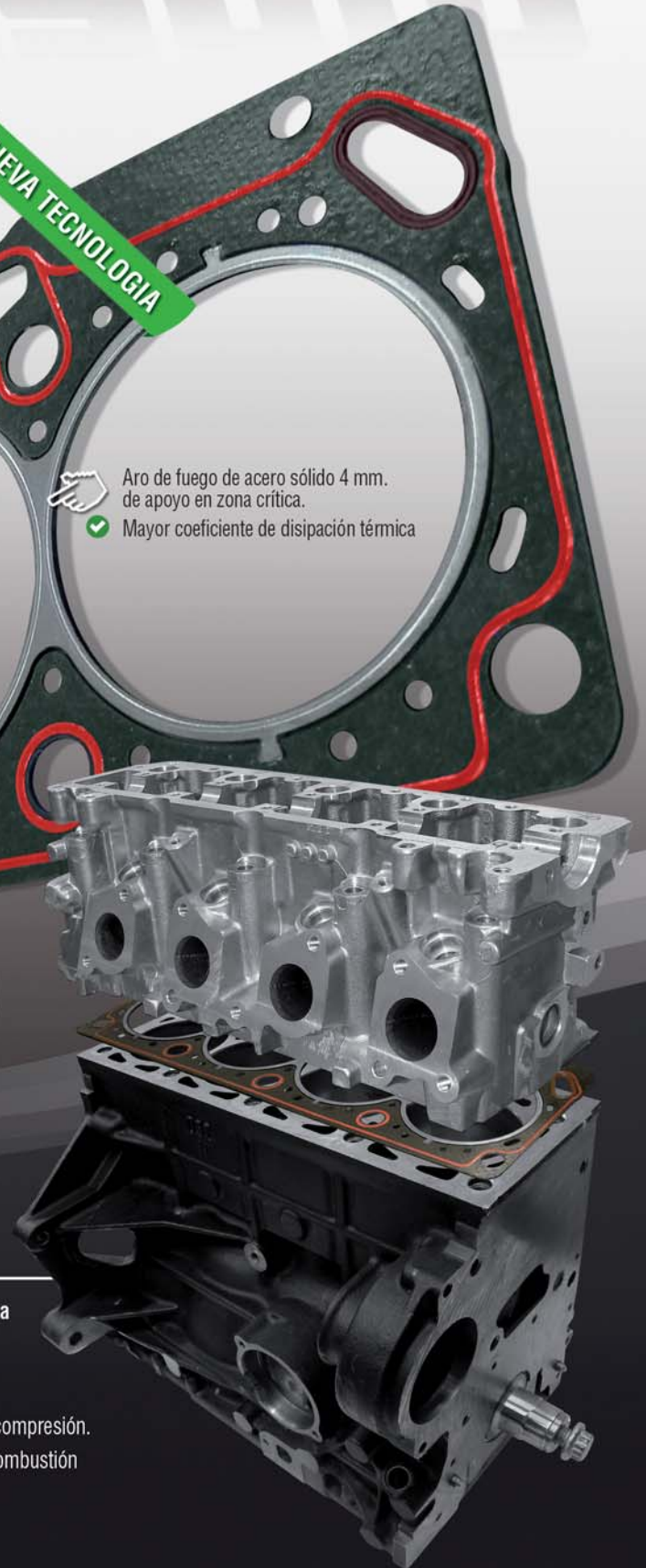

HANOMAG



Motor/Engine **R45/55/60/75** **5702** **HP** **110** **Ø**

Hanomag: Tractor - D57 1963/...

DIESEL



Nº OE	Descripción/Description	Mat.	Ref.
	Jgo. de juntas para motor		750000
507904	Junta tapa cilindros Ø 117.5 \pm 0.80	NFT	750009-0.80
507904	Junta tapa cilindros Ø 117.5 \pm 0.60	NFT	1 750009-0.60
509219	Junta tapa válvulas superior	CB	1 750010
505559	Junta para cárter	NB	1 750011
503864	Tapa distribución	NB	1 750012
512760	Bomba de agua	NB	1 750014
71511B	Jgo. múltiple escape (3)	NFT	1 750015
	Jgo. múltiple admisión (2)	NFT	1 750017
71511A	Salida de escape	NFT	1 750018
507632	Acople bomba de agua	NB	1 750019
503865	Entre caja distribución	CB	1 750029
503884	Tapa reguladora	NB	1 750030
503151	Tapa bomba inyectora	NB	1 750032
504173	Purificación aire	NB	1 750034
506676	Bomba combustible	NB	1 750035
503871	Junta tapa válvulas lateral	NB	2 750036
996800009	22 din 71511	NFT	4 750037
996800036	26 din 71511	NFT	4 750038
996800013	56 din 71511	NFT	3 750039
996800012	50 din 71511	NFT	1 750040
509199	Brida ciega	NFT	4 750041
512579	Filtro aire	NB	1 750042
504005	Salida agua	NB	1 750043
510978	Tubo aspiración	NB	1 750044
	Entrada agua	NB	1 750045
512102000	Filtro aceite	NB	1 750046
	Tapón desagote	NB	1 750047
540289	Tapa inspección	CB	1 750048
	Jgo. juntas bancada cigüeñal (2)	SNA	1 750058

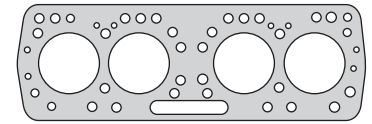

750009 - 0.60

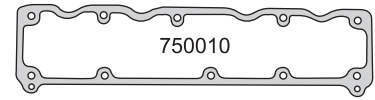

750010

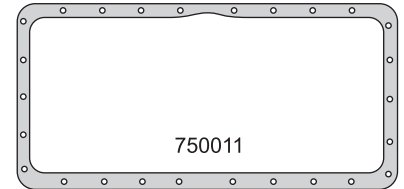

750011

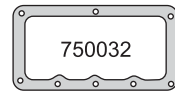

750012

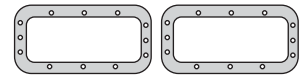

750014



750015

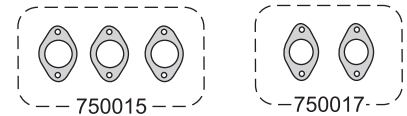

750017

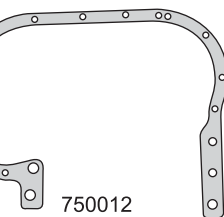

750018

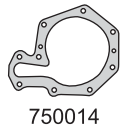

750019

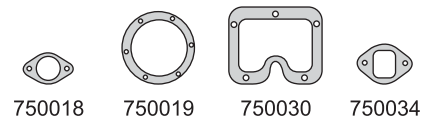

750030



750034

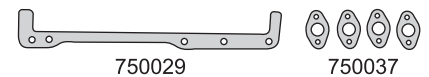

750029



750037

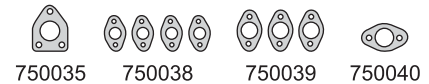

750035



750038



750039



750040



750041



750042



750043



750044



750045



750046



750058



750047

HANOMAG



Motor/Engine	Cm³	HP	Ø
R25 - L28 R35 - R40 R435 Brillant	2800		90

Hanomag: Tractor - D28LA - D28 1950/55

DIESEL



Nº OE	Descripción/Description	Mat.	Ref.
	Jgo. de juntas para motor	●	750100
151100-34	Junta tapa cilindros Ø 96 ± 1.00	NFT	1 750109
151127-3	Junta tapa válvulas superior	CG	1 750110
151100-5	Junta para cárter	CB	1 750111
151100-23	Tapa distribución	CB	1 750112
151250-16	Bomba de agua	NB	1 750114
151100-59	Múltiple admisión y escape	NFT	1 750116
151100-14	Bomba de agua a block	NB	1 750119
151253-3	Salida de agua	NB	1 750129
151100-33	Regulador refrigeración	CB	1 750130
151100-68	Tubería aceite	CB	4 750131
	Codo aspirante	CB	1 750132
	Caño admisión	CB	1 750133
151178-10	Bomba inyectora	CB	1 750134
151106-4	Brida ciega	CG	1 750135
152200-11	Junta tapa válvulas lateral	CG	2 750136
	Bomba alimentación	NB	1 750035

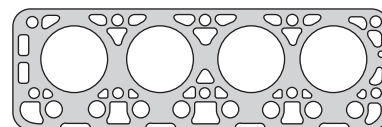

750109



750110

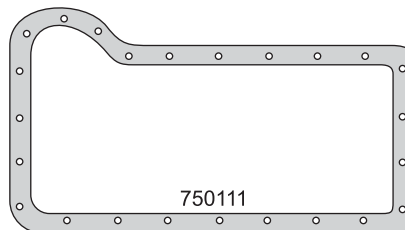

750111



750112



750116

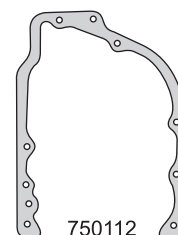

750119

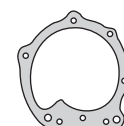

750114

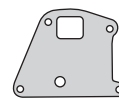

750129



750130



750131



750132



750131



750134

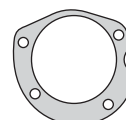

750135



750035

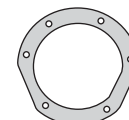

750134

HANOMAG

HANOMAG



Motor/Engine	Cm³	HP	Ø
R40 25e R57 - R46	2800		90
DIESEL			

Hanomag: Brillant - Tractor D28C 1965/71



Nº OE	Descripción/Description	Mat.	Ref.
	Jgo. de juntas para motor		750200
	Junta tapa cilindros Ø 96 ±1.00	NFT	1 750209
	Junta tapa válvulas	CG	1 750210
151100-5	Junta para cárter	CB	1 750111
	Tapa distribución	CB	1 750212
	Tapa bomba de agua	NB	1 750114
	Múltiple admisión y escape	NFT	1 750216
	Bomba de agua a block	NB	1 750119
151253-3	Salida de agua	NB	1 750129
151100-33	Regulador refrigeración	CB	1 750130
151100-68	Tubería aceite	CB	4 750131
	Codo aspirante	CB	1 750132
	Caño admisión	CB	1 750133
151178-10	Bomba inyectora	CB	1 750134
151106-4	Brida ciega	CG	1 750135
	Bomba alimentación	NB	1 750035
152200-11	Junta tapa válvulas lateral	CG	2 750136

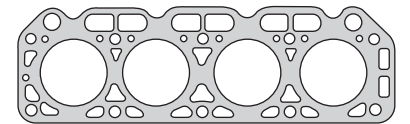

750209

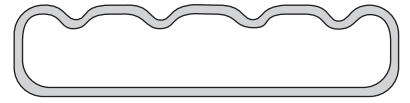

750210

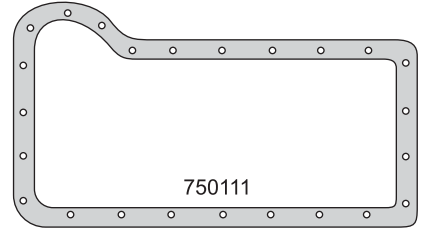

750111



750136



750216

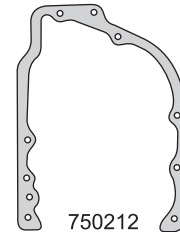

750212

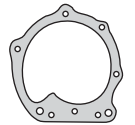

750114

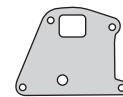

750119



750129



750130



750131



750132



750133

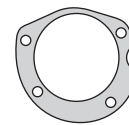

750134



750035

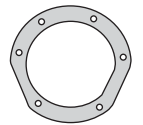

750135



taranto

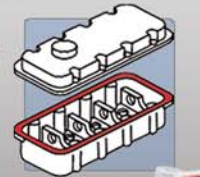
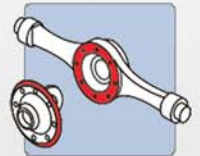

**HIGH
TEMP
350°C**

Sellador Líquido a base de Caucho de Silicona

Aprobado para motores equipados con sensor de oxígeno.

- ▶ Sellador libre de solvente, adhesivo y cubritivo compuesto a base de caucho de silicona, ha sido especialmente creado para aplicaciones de gran fuerza de torsión.
- ▶ Excelente resistencia al aceite a los combustibles, aceites, lubricantes, anticongelantes y gases.
- ▶ Resiste golpes y vibraciones.
- ▶ Es siempre flexible y se mantiene a una temperatura de entre -62°C a +350°C intermitente.

No recomendado para sellar tapas de cilindros.



JOHN DEERE



Motor/Engine	Cm³	HP	Ø
3164D	2696		102

John Deere: 1030 - 1035 - 1520
1530 - 204 - JD302 1973/...



DIESEL

Nº OE	Descripción/Description	Mat.	Ref.
	Jgo. de juntas para motor	●	85000-R
	Jgo. de juntas para motor	●	85001-R
	Junta tapa cilindros Ø 119 ± 1.40	NFT	1 850007
T 20111	Junta tapa válvulas superior	CG	1 850010
T 24534	Junta para cárter	NB	1 850011
T 20155	Tapa distribución	NB	1 850012
T 24965	Placa distribución	NB	1 850013
T 20271	Tapa bomba de agua	NB	1 850014
T 20006	Múltiple escape	FCH	3 850015
T 20243	Placa bomba de agua	NB	1 850019
T 20336	Boca llenado aceite	NB	1 850027
R 27285	Bomba alimentación	NB	1 850028
T 23596	Caja volante	NB	1 850030
T 20159	Entrada aire	NB	2 850033
T 24460	Bomba inyectora a placa block cilindro	NB	1 850034
	Arandela base silenciador	NFT	1 850035
T 20364	Tapa engranaje bomba inyectora	NB	1 850037
T 20328	Tapa boca llenado aceite	CG	1 850038
	Tapa	NB	1 850040
T 20215	Tapa termostato	NB	1 850041
T 20219	Caja termostato	NB	1 850042
A 152739	Jgo. suplemento camisa cilindros	GS	3 850070
	O´ring suplemento camisa G105.46 x 3.53 (3)	GS	
	O´ring suplemento camisa G110 x 3.53 (Rojo) (3)	S	
	O´ring suplemento camisa G110 x 3.53 (Verde) (3)	S	
	Retén bancada 120.65 x 146.07 x 12.7	P	1 R850011P
	Retén distribución 57.15 x 76.2 x 9.5	P	1 R850012P

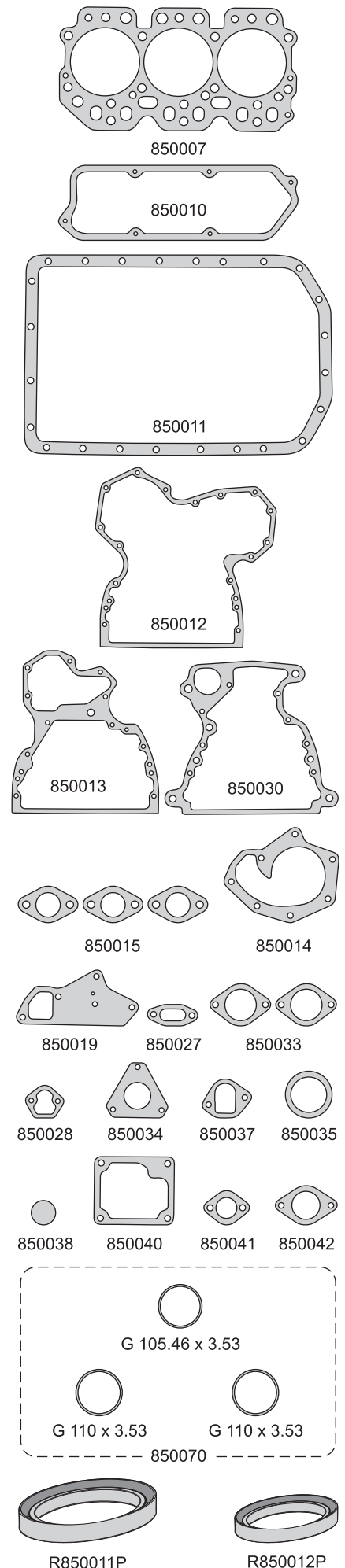

JOHN DEERE

JOHN DEERE



Motor/Engine	Cm³	HP	Ø
4219 D	3590	81	102
4239 D/T	3918	81	102

John Deere: Tractor - Equipos Viales 2120/ 2030 2035/ 2270/ 2280/ 2340/ JD310 401/ 440/ 450/ 480 1974/... 2130/ 2135/ 1640/ 1840/ 2040/ 2140 JD4400/ 540B/ 550/ 555 1980/...



DIESEL

Nº OE	Descripción/Description	Mat.	Ref.
	Jgo. de juntas para motor	●	850100-R
	Jgo. de juntas para motor	●	850101-R
T 20075	Jta. tapa cilindros Ø 119 \pm 1.40	NFT	1 850107
T 32266	Junta tapa válvulas superior	CG	1 850110
	Junta para cárter	NB	1 850111
T 20155	Tapa distribución	NB	1 850012
T 24965	Placa distribución	NB	1 850013
T 20271	Tapa bomba de agua	NB	1 850014
T 20006	Múltiple escape	FCH	4 850015
T 20243	Placa bomba de agua	NB	1 850019
T 20336	Boca llenado aceite	NB	1 850027
R 27285	Bomba alimentación	NB	1 850028
T 23596	Caja volante	NB	1 850030
T 20159	Entrada aire	NB	2 850033
T 24460	Bomba inyectora a placa block cilindro	NB	1 850034
	Arandela base silenciador	NFT	1 850035
T 20364	Tapa engranaje bomba inyectora	NB	1 850037
T 20328	Tapa boca llenado aceite	CG	1 850038
	Tapa	NB	1 850040
T 20215	Tapa termostato	NB	1 850041
T 20219	Caja termostato	NB	1 850042
	Jgo. juntas caja de velocidades	VS	850150
A 152739	Jgo. suplemento camisa cilindros	GS	4 850070
	O'ring suplemento camisa G105.46 x 3.53 (4)	N	
	O'ring suplemento camisa G110 x 3.53 (Rojo) (4)	S	
	O'ring suplemento camisa G110 x 3.53 (Verde) (4)	S	
	Retén bancada 120.65 x 146.07 x 12.7	P	1 R850011P
	Retén distribución 57.15 x 76.2 x 9.5	P	1 R850012P

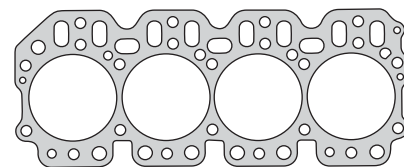

850107

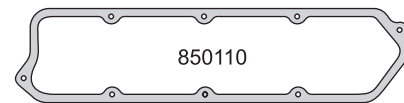

850110

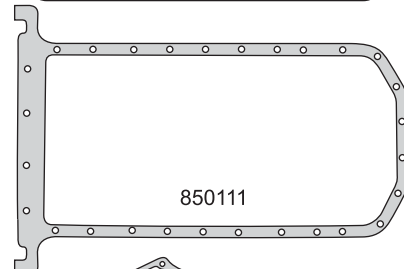

850111

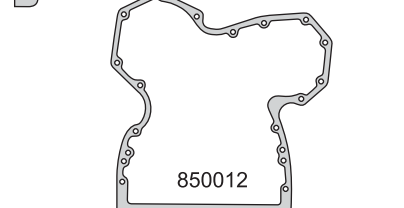

850012

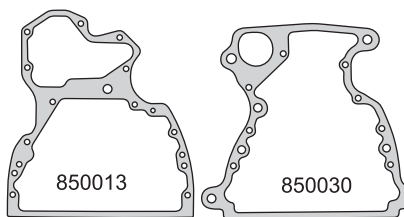

850013

850030

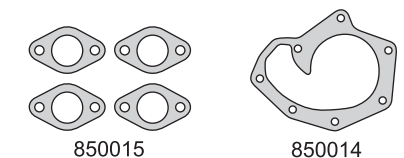

850015

850014

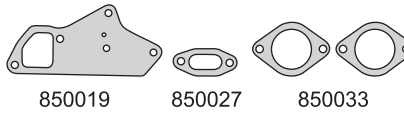

850019

850027

850033

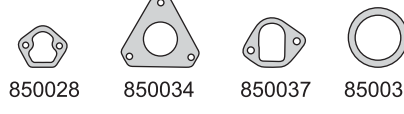

850028

850034

850037

850035

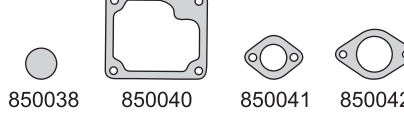

850038

850040

850041

850042

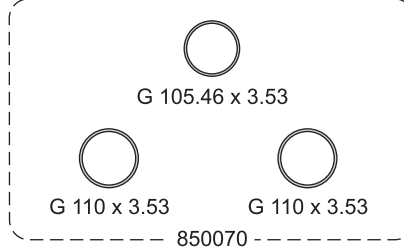

G 105.46 x 3.53

G 110 x 3.53

G 110 x 3.53

850070

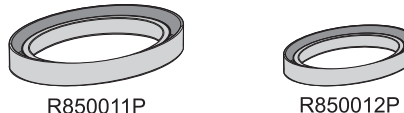

R850011P

R850012P

JOHN DEERE

JOHN DEERE



Motor/Engine	Cm³	HP	Ø
6.329D	5395	87	102
6.359D	5877	87	106.5

John Deere: Tractor Motoniveladora
 6329D - 3120/3130/3135/2840/630
 730/JD303/444/540/570/482
 6359D - 3140/3040/3640/4040/960
 975/2940/3050/3350/3650



DIESEL

Nº OE	Descripción/Description	Mat.	Ref.
AJ 53537	Jgo. de juntas para motor	●	850200-R
	Jgo. de juntas para motor		850201-R
R 59449	Junta tapa cilindros Ø 119 \pm 1.40	NFT	1 850207
T 20467	Junta tapa válvulas superior	CG	1 850210
T 32267	Junta para cárter	NB	1 850211
T 20155	Tapa distribución	NB	1 850012
T 24965	Placa distribución	NB	1 850013
T 25485	Tapa bomba de agua	NB	1 850214
T 20006	Múltiple escape	FCH	6 850015
T 20243	Placa bomba de agua	NB	1 850019
T 20336	Boca llenado aceite	NB	1 850027
R 27285	Bomba alimentación	NB	1 850028
T 23596	Caja volante	NB	1 850030
T 20159	Entrada aire	NB	2 850033
T 24460	Bomba inyectora a plano block cilindro	NB	1 850034
R 31142	Arandela base silenciador	NFT	1 850235
T 20364	Engranaje bomba inyectora	NB	1 850037
T 20328	Tapa boca llenado aceite	CG	1 850038
T 23002	Múltiple salida agua	CG	3 850239
T 24932	Tapa termostato	NB	1 850241
R 54641	Caja termostato	CB	1 850242
R 54638	Tapa caja termostato	CB	1 850243
A 152739	Jgo. suplemento camisa cilindros (6)	GS	1 850071
	Retén bancada 120.65 x 146.07 x 12.7	P	1 R850011P
	Retén distribución 57.15 x 76.2 x 9.5	P	1 R850012P

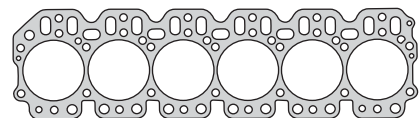

850207



850210

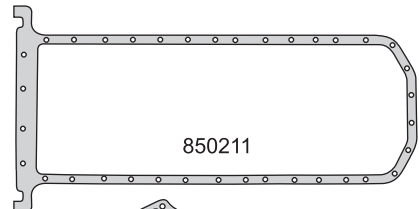

850211

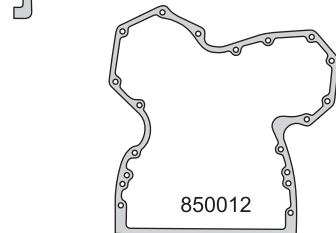

850012

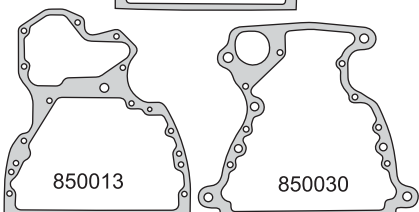

850013

850030

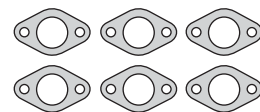

850015

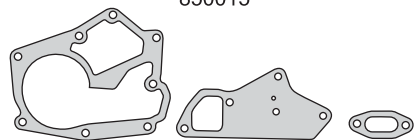

850214

850019

850027



850028

850033

850034

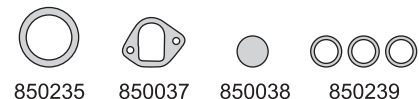

850235

850037

850038

850239



850241

850242

850243



850071



R850011P



R850012P

JOHN DEERE



Motor/Engine	Cm³	HP	Ø
303	4976	85	98.04
329	5393	87	102

John Deere: 3420 - J10 - 4420 - 570
Tractor Motoniveladora 1972/...



DIESEL

Nº OE	Descripción/Description	Mat.	Ref.
	Jgo. de juntas para motor	●	850300-R
	Junta tapa cilindros Ø 115 ± 1.40	NFT	1 850307
T 20467	Junta tapa válvulas superior	CG	1 850210
T 32267	Junta para cárter	NB	1 850211
T 20155	Tapa distribución	NB	1 850012
T 24965	Placa distribución	NB	1 850013
T 25485	Tapa bomba de agua	NB	1 850214
T 20006	Múltiple escape	FCH	6 850015
T 20243	Placa bomba de agua	NB	1 850019
T 20336	Boca llenado aceite	NB	1 850027
R 27285	Bomba alimentación	NB	1 850028
T 23596	Caja volante	NB	1 850030
T 20159	Entrada aire	NB	2 850033
T 24460	Bomba inyectora a placa block cilindro	NB	1 850034
R 31142	Arandela base silenciador	NFT	1 850235
T 20364	Engranaje bomba inyectora	NB	1 850037
T 20328	Tapa boca llenado aceite	CG	1 850038
T 23002	Múltiple salida agua	CG	3 850239
T 24932	Tapa termostato	NB	1 850241
	Jgo. suplemento camisa cilindros	GS	6 850070
	O ring suplemento camisa G105.46 x 3.53 (6)	N	
	O ring suplemento camisa G110 x 3.53 (Rojo) (6)	S	
	O ring suplemento camisa G110 x 3.53 (Verde) (6)	S	
	Retén bancada 120.65 x 146.07 x 12.7	V	1 R850011V
	Retén distribución 57.15 x 76.2 x 9.5	P	1 R850012P

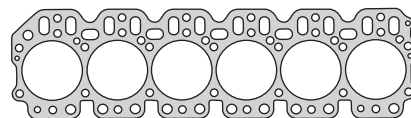

850307

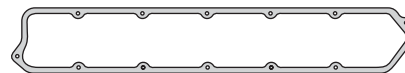

850210

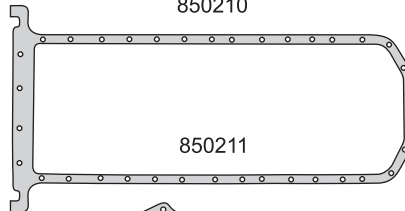

850211

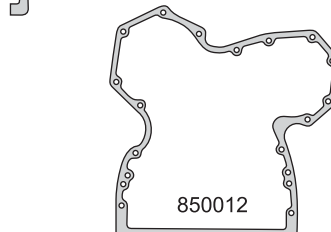

850012

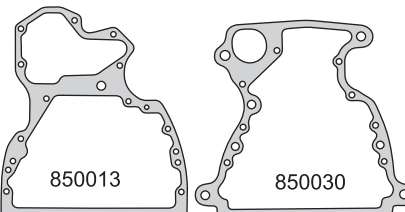

850013

850030

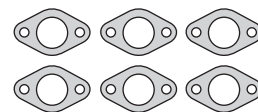

850015



850214

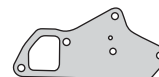

850019

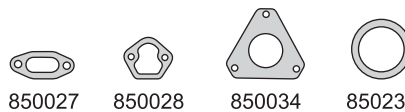

850027

850028

850034

850235



850037

850033

850241



850239



850038

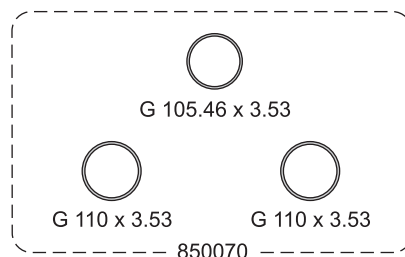

G 105.46 x 3.53

G 110 x 3.53

G 110 x 3.53

850070



R850011V



R850012P

JOHN DEERE



Motor/Engine	Cm³	HP	Ø
6.359D	5879	110/125	106.5
DIESEL			

John Deere: 3350 - 3550 - 6500 - 6600 - 7500
Cosechadora 1075 1991/...



Nº OE	Descripción/Description	Mat.	Ref.
	Jgo. de juntas para motor	●	850400
	Jgo. de juntas para motor		850401
R114157	Junta tapa cilindros Ø 119 \pm 1.40	NFT	1 850207
R75728	Junta tapa válvulas superior	CG	1 850210
R97344	Junta para cárter	NB	1 850411
R126513	Tapa distribución	NB	1 850012
R131794	Placa distribución	NH	1 850413
T20243	Tapa bomba de agua	NB	1 850214
R119395	Jgo. múltiple escape (6)	AC	1 850415
	Jgo. múltiple escape (6)	NFT	1 850416
	Placa bomba de agua	NB	1 850019
R87259	Boca llenado aceite	NB	1 850027
R97350	Bomba alimentación	NB	1 850028
R97351	Caja volante	NB	1 850030
R81275	Entrada aire	NB	1 850033
R97354	Bomba inyectora a placa distribución	NB	1 850034
	Arandela base silenciador	NFT	1 850235
R125026	Tapa engranaje bomba inyectora	NB	1 850037
	Tapa bomba llenado aceite	CG	1 850038
	Múltiple salida agua	CG	3 850239
R54638	Tapa termostato	NB	1 850241
R54641	Caja termostato	CB	1 850242
	Tapa caja termostato	CB	1 850243
	Jgo. caja de velocidades transmisión	VS	850450
R87879	Salida escape turbo	AC	850463
AR65507	Jgo. suplemento camisa cilindros (6)	GS	1 850071
	Jgo. suplemento camisa cilindros (6)	GS	850470
	O´ring G 110 x 3.53	GS	6
	O´ring G 117.07 x 3.53	GS	6
	O´ring G 15.6 x 1.78	GS	1
	O´ring G 24.99 x 3.53	GS	1
	O´ring G 28.17 x 3.53	GS	2
	Anillo G 69 x 77 x 5	GS	1
RE44574	Retén bancada 120.65 x 146.07 x 12.7	P	R850011P
AR67942	Retén distribución 57.15 x 76.2 x 9.5	P	R850012P

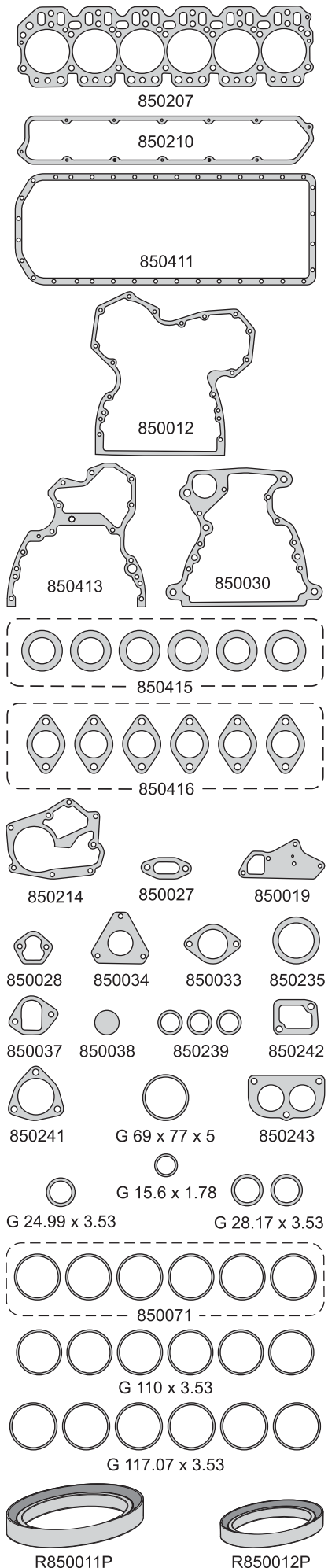

JOHN DEERE

JOHN DEERE



Motor/Engine	Cm³	HP	Ø
	6156		155.6
DIESEL			

John Deere: 730 - Tractor 375 1960/74



Nº OE	Descripción/Description	Mat.	Ref.
	Jgo. de juntas para motor		850500-R
R 21449 R	Junta tapa cilindros Ø 156 ± 1.60	NFT 1	850507
	Junta tapa balancines	CG 1	850510
F 1898 R/J	Junta cuerpo bomba de agua	NB 1	850514
J 10081 J	Jgo. múltiple escape (3)	NFT 1	850515
	Termostato	CB 1	850519
	Entrada agua a tapa cilindros	CB 1	850529
F 519 R/J	Soporte motor arranque	CB 1	850530
R 20169 R/J	Base cilindros a caja	NFT 1	850531
F 2251 R	Salida agua cabeza cilindros	CB 2	850532
F 1779 R/J	Tapa caja cigüeñal lado derecho	CG 1	850533
F 1803 R/J	Salida agua block	CB 1	850534
F 1777 R/J	Soporte bomba inyectora a cilindros	NB 2	850535
F 2438 R/J	Tapa bombas inyectora	CG 1	850536
R 61 R/J	Tapa cojinete extremo eje transmisión	CG 1	850537
A 3817 R/J	Freno derecho	CB 1	850538
F 157 R/J	Caja retén de aceite volante	CB 1	850539
R 20232 R	Purificador aire	CG 1	850540
R 20037 R/J	Caja palanca reguladora	CB 1	850541
F 2043 R/J	Caja regulador	CB 1	850542
F 2041 R/J	Caja cojinete	CB 1	850543
F 1922 R/J	Cubierta 1ra. reguladora engranaje	CB 1	850544
F 2504 R/J	Cubierta reguladora engranaje	CB 1	850545
F 2589 R/J	Retén aceite polea	CB 1	850546
F 1396 R/J	Arandela espárrag. cabeza cilindros A 20 x 28 x 1 C	CU 10	850547
264 R/J	Arandela bulón sujeta tapa bomba A 11 x 18 x 1.5 A	AL 2	850548
A 3439 R/J	Arandela bulón sujeta tapa balancines A 11 x 18 x 1.5 C	CU 3	850549
A 3439 R/J	Arandela tobera inyector A 8 x 18 x 1.5 A	AL 2	850562
R 463	Empaquetadura caño agua inferior G 62.87 x 5.33	GS 2	850563
F 1056 R	Empaquetadura tubo entrada aceite bba G 9.19 x 2.62	GS 2	850564
A 4365 R	Empaquetadura caño agua superior G 46.99 x 5.33	GS 2	850565
RE44574	Retén bancada 101.60 x 127 x 7.94	P 1	R850511P
AR67942	Retén distribución 57.15 x 76.2 x 9.5	P 1	R850512P

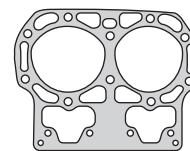

850507



850510

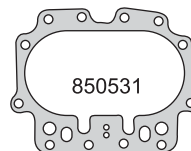

850531



850536

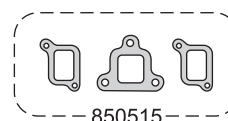

850515

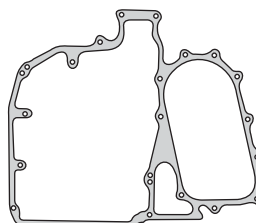

850545

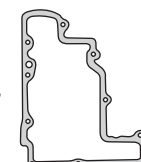

850542



850514



850519



850529



850530



850532



850533



850534

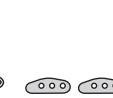

850535



850537



850538



850539



850540



850543



850541

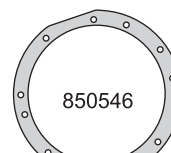

850546

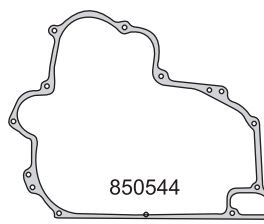

850544



850547



850548



850549



850562



850563



850564



850565



R850511P



R850512P

JOHN DEERE

JOHN DEERE



Motor/Engine	Cm³	HP	Ø
6068TJ31/32/61 6068HJ63	5395	150/178	106

John Deere: 6505 - 6605 - 6615 - 7500
Power Tech - MUM
Power Tech - Gen Set



DIESEL

Nº OE	Descripción/Description	Mat.	Ref.
	Jgo. de juntas para motor	●	850601-R
	Jgo. de juntas para motor		850601
	Juntas tapa cilindros Ø 120 \pm 1.40	NFT	850607
	Junta tapa válvulas	P	1 850610
	Junta para cárter	NB	1 850611
	Junta distribución	NH	1 850612
	Junta distribución	NH	1 850612-1
	Junta distribución	NH	1 850612-2
	Junta distribución	NH	1 850612-3
	Junta placa distribución	NH	1 850613
	Jgo. múltiple escape (6)	AC	1 850615
	Junta	GFT	1 850630
	Junta	CB	1 850637
	Junta	CB	1 850638
	Junta	NB	1 850639
	Junta	CB	1 850640
	Junta	CB	1 850641
	Junta	NB	2 850642
	Junta tapa termostato	CB	1 850243
	Junta	CB	1 850643
	Junta	NB	1 850647
	Junta	NB	1 850648
	Junta	AC	1 850662
	Arandela A 26 x 32 x 1.25 A	AL	1
	O'ring G 18.64 x 3.53	GS	4
	O'ring G 7.59 x 2.62	GS	6
	O'ring G 15.47 x 3.53	GS	2
	O'ring G 37.77 x 2.62	GS	2
	O'ring G 29.87 x 1.78	GS	2
	O'ring G 31.47 x 1.78	GS	1
	O'ring G 18.77 x 1.78	GS	1
	O'ring G 24.99 x 3.53	GS	1
	O'ring G 50.39 x 3.53	GS	1
	O'ring G 91.67 x 3.53	GS	1
	O'ring G 69.52 x 2.62	GS	1
	Kit de retenes completo		R850600
	Jgo. retén válvulas (12)	V	1 R850610V
	Retén bancada 120.65 x 146.07 x 12.7	P	1 R850011P
	Retén distribución 57.15 x 76.2 x 9.5	P	1 R850012P

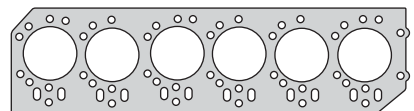

850607

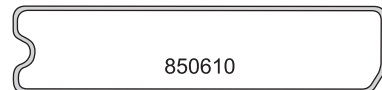

850610

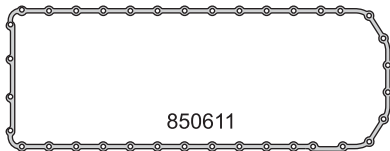

850611

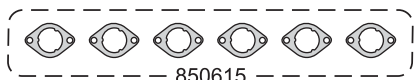

850615

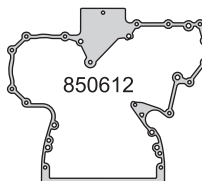

850612

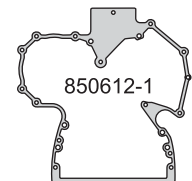

850612-1

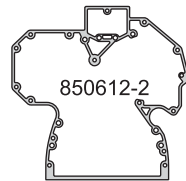

850612-2

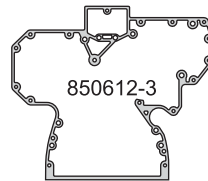

850612-3

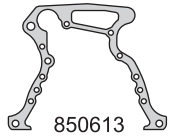

850613

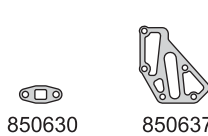

850630



850637



850638



850639

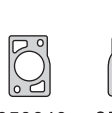

850640



850641

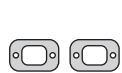

850642



850643

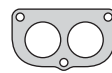

850243

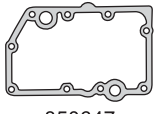

850647



850648

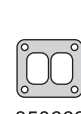

850662



A 26 x 32 x 1.25 A

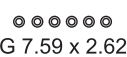

G 7.59 x 2.62



G 18.64 x 3.53



G 37.77 x 2.62



G 29.87 x 1.78



G 31.47 x 1.78

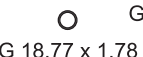

G 18.77 x 1.78



G 24.99 x 3.53



R850011P



R850012P



R850610V

JOHN DEERE

JOHN DEERE



Motor/Engine	Cm³	HP	Ø
4540TJ31	4500	107	106
4045DJ31	4500	74	106

John Deere: Motores Agrícolas e Industriales



DIESEL

Nº OE	Descripción/Description	Mat.	Ref.
	Jgo. de juntas para motor	●	850701-R
	Jgo. de juntas para motor		850701
	Junta tapa cilindros Ø 120 \pm 1.40	NFT	850707
	Junta tapa válvulas	GS 1	850710
	Junta para cárter	NB 1	850711
	Junta distribución	NH 1	850612
	Junta distribución	NH 1	850612-1
	Junta distribución	NH 1	850612-2
	Junta distribución	NH 1	850612-3
	Placa distribución	NH 1	850613
	Jgo. múltiple escape (4)	AC 1	850715
	Junta	GFT 1	850630
	Junta	CB 1	850637
	Junta	CB 1	850638
	Junta	NB 2	850639
	Junta	CB 1	850640
	Junta	CB	850641
	Junta	NB 1	850642
	Junta	CB 1	850643
	Junta radiador aceite	NB 1	850647
	Junta radiador aceite	NB 1	850648
	Junta turbo	AC 1	850762
	Arandela A 26 x 32 x 1.25 A	AL 1	
	O'ring G 18.64 x 3.53	GS 4	
	O'ring G 7.59 x 2.62	GS 4	
	O'ring G 15.47 x 3.53	GS 2	
	O'ring G 34.52 x 3.53	GS 2	
	O'ring G 29.82 x 2.62	GS 2	
	O'ring G 31.42 x 2.62	GS 1	
	O'ring G 18.72 x 2.62	GS 1	
	O'ring G 24.99 x 3.53	GS 1	
	O'ring G 50.39 x 3.53	GS 1	
	O'ring G 91.67 x 3.53	GS 1	
	O'ring G 69.52 x 2.62	GS 1	
	Kit de retenes completo		R850700
	Jgo. retén válvulas (8)	V 1	R850710V
	Retén bancada 120.65 x 146.07 x 12.7	P 1	R850011P
	Retén distribución 57.15 x 76.2 x 9.5	P 1	R850012P

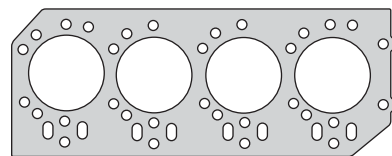

850707

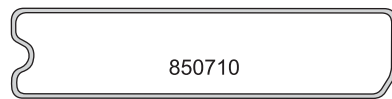

850710

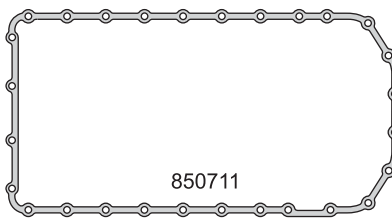

850711

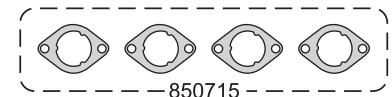

850715

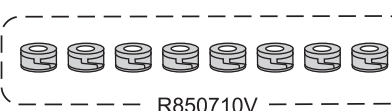
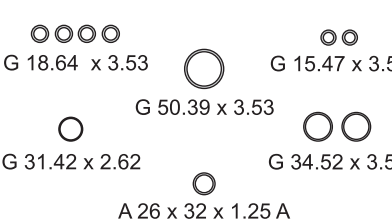
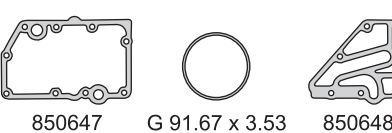
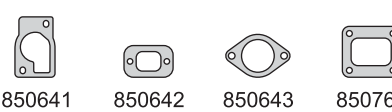
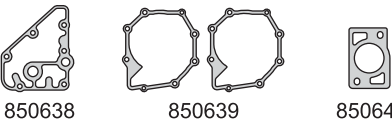
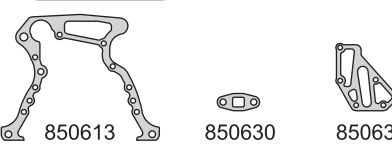
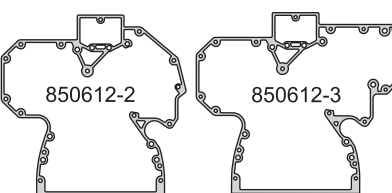
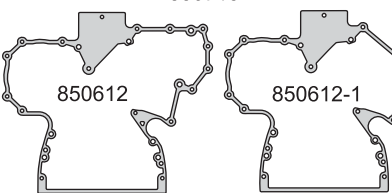

JOHN DEERE

MASSEY FERGUSON



Motor/Engine	Cm³	HP	Ø
MF165 - 265	3336	71	91.49

Massey Ferguson: Tractor M165 - 265



DIESEL

Nº OE	Descripción/Description	Mat.	Ref.
	Jgo. de juntas para motor		400700-R
	Junta tapa cilindros Ø 92.5 ± 1.40	NFT	400005
36812125	Junta tapa cilindros Ø 92.5 ± 1.40	NFT	400007
36812125	Junta tapa cilindros Ø 92.5 ± 1.15	CNC	400008
	Jgo. tornillos tapa cilindros (HAS19038)		B400000
0490704	Conj. junta tapa válvulas superior (4)	CG	400010
006012	Jgo. junta para cárter (4)	NB	400711
006013	Tapa distribución	NB	400612
36814112	Block caja distribución	NB	400013
36866417	Bomba de agua placa trasera	NB	400014
006002	Jgo. múltiple escape (2)	FCH	400015
006061	Múltiple admisión	NFT	400017
0490032	Salida de escape	FCH	400018
	Salida de escape	NFT	400718
	Arandela tapa válvulas	GS	400130
006020	Brida bomba hidráulica	NB	400631
0920113	Arandela base inyector A 14.5 x 20.5 x 1.5 C	CU	400033
33825409	Tapa frontal a tapa inspección	NB	400034
006081	Tapa trasera cigüeñal	NB	400035
0490485	Tapa trasera tapa cilindros	NB	400036
006054	Tapa precámara combustión	CU	400037
	Precámara combustión combustible	AL	410037
33826111	Porta retén bancada trasera	NB	400038
	Tapa trasera termoarranque	CG	400140
0490685	Comando bomba combustible	NB	400146
0490699	Tapa trasera árbol levas	NB	400047
0490692	Conexión entrada agua	NB	400048
36835411	Conexión salida agua	NB	400051
0490024	Salida agua a tapa	NB	400052
0490391	Cuerpo codo paso agua	NB	400153
006007	Filtro aceite a block	NB	400057
36883106	Jgo. juntas bancada cigüeñal (2)	SLA	400158
	Unión manga diferencial	CB	400759
006074	Bomba alimentación combustible	NB	400165
36865543	Soporte bomba inyectora	NB	400066
	O'ring G 18.77 x 1.78	GS	400767
	Kit de arandelas (57)	VS	400075
	Arandela A 10 x 14 x 1 A	AL	15
	Arandela A 13 x 20 x 1 A	AL	10
	Arandela A 17.5 x 22 x 1 A	AL	10
	Arandela A 19 x 27 x 2 A	AL	1
	Arandela A 8 x 12.5 x 1 A	AL	15
	Kit de retenes completo		R400000-1
	Jgo. retén válvulas (8)	P	1 R400010P
	Jgo. retén válvulas (8)	P	1 R300310P
	Retén bancada 133.35 x 158.75 x 11/13	P	1 R400211P
	Retén distribución 60.32 x 79.36 x 9.5	P	1 R400012P

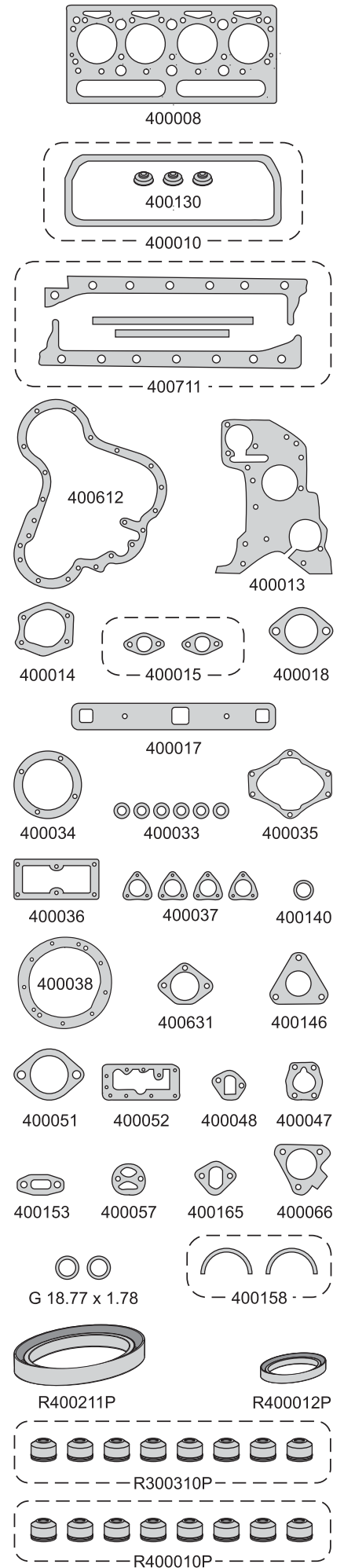

MASSEY FERGUSON



Motor/Engine	Cm³	HP	Ø
6.354-2	5798	140	98.3

Massey Ferguson: Tractor 1095 - 1098 - 1195
1215

DIESEL



Nº OE	Descripción/Description	Mat.	Ref.
	Jgo. de juntas para motor		400800-R
36812545	Junta tapa cilindros Ø 104 \pm 1.50	NFT	400207
36812545	Junta tapa cilindros Ø 104 \pm 1.30	CHA	400208
	Jgo. tornillos tapa cilindros (HAS19038)		B400200
36811412	Junta tapa válvulas superior	CG	400210
36816702	Junta para cárter	NB	400211
36814124	Distribución a block	NB	400212
36867139	Bomba de agua placa	NB	400814
	Jgo. múltiple escape (3)	FCH	400215
	Jgo. múltiple admisión (4)	NFT	400217
0490301	Salida de escape	FCH	400218
36867117	Placa montaje a block	NB	400819
0490485	Tapa trasera tapa cilindros	NB	400036
003202	Base filtro aceite c/ ref.	NB	400237
	Base filtro aceite s/ ref.	NB	400238
36831118	Válvula reguladora a block	NB	400239
	Jgo. juntas compresor tensa	VS	400240
	Tapa trasera termoarranque	CG	400140
36846408	Inspección botadores	NB	400242
32811408	Lateral puente a block	GS	400442
36826107	Inspección engranaje árbol de levas	CG	400243
36866434	Inspección engranaje comando auxiliar	NB	400244
	Vaso filtro nafta	CG	450045
33828108	Comando bomba combustible	NB	400246
36832118	Brida caño succión a bomba	NB	400249
36866426	Acople compresor a block	NB	400250
36835411	Conexión salida agua	NB	400051
36846113	Cuerpo salida agua tapa cilindros	NB	400254
	Jgo. empaquetadura cigüeñal (2)	SLA	400158
36811412	Junta tapa válvulas superior	CG	400261
36862126	Bomba alimentación combustible	NB	400165
	Junta base alimentación	NB	400465
	Kit de arandelas (57)	VS	400175
36867132	Placa cuerpo múltiple admisión	NB	400282
36817136	Porta retén bancada trasera	NB	400283
36822118	Placa adaptador bomba inyección	NB	400284
36866432	Placa montaje a conexión	NB	400885
	Arandela inyector A 14 x 20 x 1.25 C	CU	6
	Arandela A 10 x 14 x 1 A	AL	15
	Arandela A 13 x 20 x 1.25 A	AL	10
	Arandela A 17 x 22 x 1 A	AL	10
	Arandela A 19 x 27 x 2 A	AL	1
	Arandela A 8 x 12 x 1 A	AL	15
	Kit de retenes completo		R400200
	Jgo. retén válvulas (12)	P	1 R400210P
	Retén bancada 133.35 x 158.75 x 11/13	P	1 R400211P
	Retén distribución 60.32 x 79.36 x 9.5	P	1 R400012P
	Retén auxiliar 22.22 x 35.70 x 9.52	N	1 R400215N

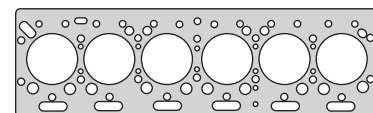

400208



400210

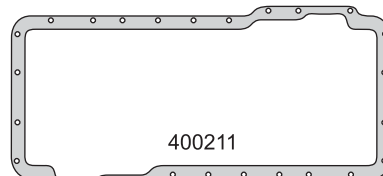

400211

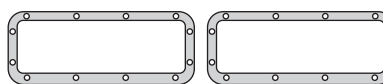

400212

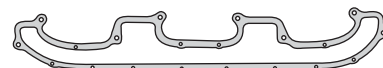

400215

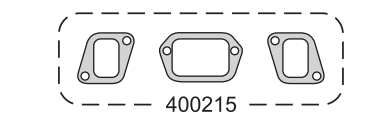

400217

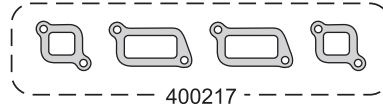

400218

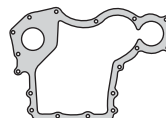

400814

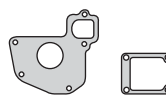

400036



400237



400238

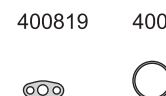

400239



400140



400442



400244



400243



400246



450045



450045



400249



400250



400051



400254

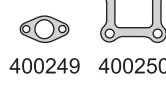

400165



400283



400284



400885



400158



400465



R400211P



R400012P



R400215N



R400210P



R400210P



R400210P



R400210P



R400210P



R400210P

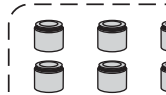

R400210P



R400210P



R400210P



R400210P



R400210P



R400210P

M. FERGUSON

**MERCEDES
BENZ**



Motor/Engine **L911 OM311/312** **CM³** **4580** **HP** **98** **Ø** **90**

Mercedes Benz: MB 3500 - L3250 - L3500
1949/52

DIESEL



Nº OE	Descripción/Description	Mat.	Ref.
	Jgo. de juntas para motor		350000-R
3120162120	Junta tapa cilindros Ø 93 ± 1.40	NFT	1 350005
	Jgo. de tornillos para tapa de cilindros		B350000
3520160421	Junta tapa válvulas superior	CG	350310
3520160421	Junta tapa válvulas superior	NH	350331
3520160421	Junta tapa válvulas superior	NFT	1 350332
3525860301	Jgo. junta para cárter (4)	CG	1 350011
3520150320	Tapa distribución	CG	1 350012
3120150580	Placa distribución	NB	1 350013
3122010480	Tapa bomba de agua	NB	1 350014
3521420180	Jgo. múltiple escape (2)	NFT	1 350015
3524921080	Salida de escape	FCH	1 350018
3122010380	Placa bomba de agua	NB	1 350019
3121841079	Filtro aceite a block	NB	1 350027
	Junta tapa cilindros compresor aire	NB	1 350034
3520150522	Junta tapa válvulas lateral	CG	1 350036
3211880179	Refrigerador aceite	CB	1 350037
3121881479	Tapa refrigerador aceite	NB	1 350038
	Arandela radiador aceite	NB	16 350040
	Junta tapa cilindros compresor aire	NB	1 350042
3520760279	Soporte bomba inyectora	NB	1 350045
3120150680	Cierre distribución	CG	1 350046
	Jgo. juntas refrigeración aceite	VS	350048
	Jgo. juntas refrigeración P. P.	VS	1 350048B
	Jgo. juntas caja de velocidades G-27	CB	350050
	Palier	AL	350256
	Jgo. empaquetadura cigüeñal (2)	SNA	1 350458
	Tapa diferencial	CG	350059
3525860301	Jgo. junta para cárter (2)	CGT	350060
	Tapa diferencial	CG	350069
	O'ring camisa inyector G 30.54 x 7.3	GS	
	Anillo retorno inyector G 6.5 x 14 x 8	GS	
	Retén distribución 65 x 90 x 15	S	1 R350212S

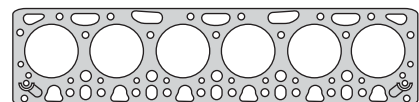

350005

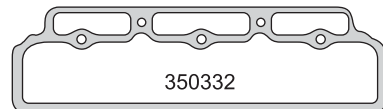

350332

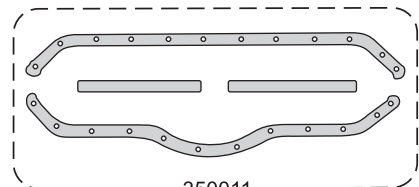

350011

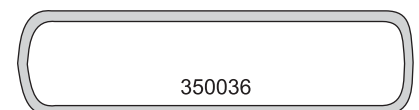

350036

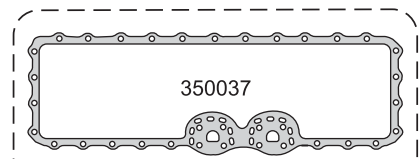

350037



350040

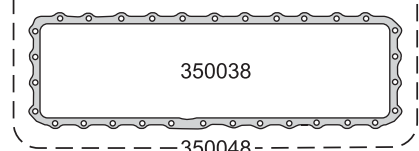

350038

350048

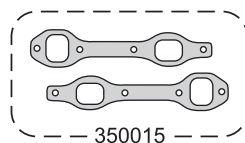

350015

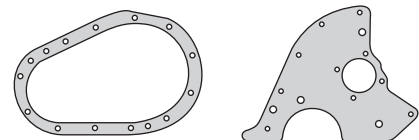

350012

350013

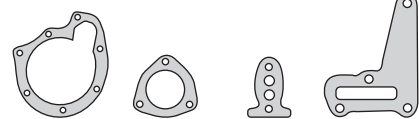

350014

350018

350027

350019

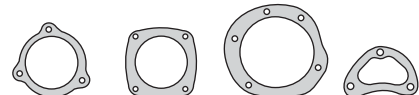

350034

350042

350045

350046

G 6.5 x 14 x 8



G 30.54 x 7.3

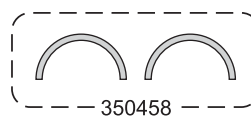

350458



R350212S

M. BENZ

**MERCEDES
BENZ**



Motor/Engine	Cm³	HP	Ø
OM 314	3786	85	97

Mercedes Benz: MB L608 D/Unimog
1966/...

DIESEL



Nº OE	Descripción/Description	Mat.	Ref.
	Jgo. de juntas para motor		350100-R
	Jgo. de juntas superior		350195
3140160220	Junta tapa cilindros Ø 99 ± 1.40	NFT 1 1	350805
	Junta tapa cilindros Ø 99 ± 1.40 N.R.	NFT	350807
	Jgo. tornillos tapa cilindros (HAD19038)		B350100
3140160221	Junta tapa válvulas superior	NFT 1 1	350132
3140160221	Junta tapa válvulas superior	NH	350131
3140160221	Junta tapa válvulas superior	CG	350110
3140140772	Jgo. junta para cárter (4)	CG 1	350111
3520150320	Tapa distribución	CG 1	350012
3520150320	Tapa distribución	NB 1	350312
3120150580	Placa distribución	NB 1	350013
3522010480	Tapa bomba de agua	NB 1	350314
3141420080	Múltiple admisión y escape	NFT 1 1	350115
3094920080	Salida de escape	FCH 1	350118
3141840379	Base filtro aceite	NB 1	350127
3140160280	Salida agua	NB 1 1	350129
3141840079	Base filtro aceite	NB 1	350130
	Arandela doble raccord	CU 4 4	350032
3240150080	Tapa lateral agua a block	NB 1	350133
3211310079	Cilindros compresor aire	NB 1	350034
	Carcasa termostato	NB 1 1	350035
3140150622	Junta tapa válvulas lateral	CG 1	350136
3522030780	Tapa carcasa termostato	NB 1 1	350041
3211310279	Cabeza cilindros compresor	NB 1	350042
3522030080	Galería superior agua	NB 3 3	350043
3120760279	Galería inferior agua	NB 2 2	350044
3120150680	Soporte bomba inyectora	NB 1	350045
	Cierre distribución	CG 1	350046
	Jgo. juntas caja de velocidades	VS	350150
	Palier	AL	350256
	Jgo. empaquetadura cigüeñal (2)	SNA 1	350458
3140140772	Tapa diferencial	CG	350159
	Jgo. junta para cárter	CGT	350160
0169978248	O'ring camisa inyector G 30.8 x 3.7	GS 4 4	350840
3129970840	Tubo retorno G 6.4 x 13.8 x 8	GS 5	
	Arandela A 10 x 20 x 1C	CU 4 4	
	Arandela A 16 x 22 x 1.5 A	AL 2 2	
	Arandela A 20 x 24 x 1.5 A	AL 1 1	
	Arandela A 24 x 32 x 2 A	AL 1 1	
	Arandela A 26 x 32 x 2 A	AL 1	
	Arandela A 8 x 14 x 1C	CU 6 6	
	O'ring G 13.94 x 2.62	GS 1	
	Jgo. retén válvulas (8)	P	R350110P
	Retén distribución 65 x 90 x 15	S 1	R350212S

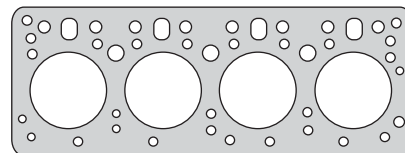

350805

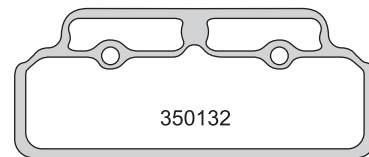

350132

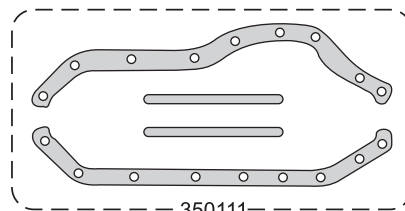

350111

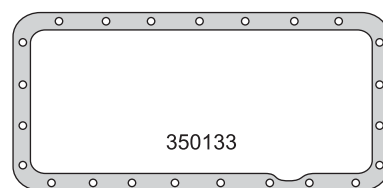

350133

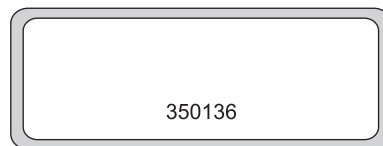

350130



350127

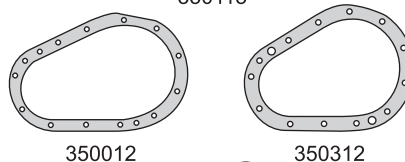

350041

350042

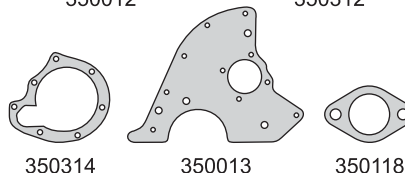

350012

350312

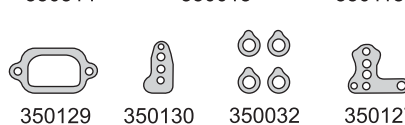

350314

350013

350118

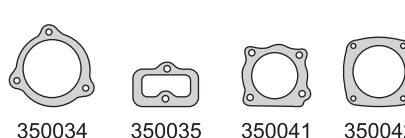

350129

350130

350032

350127

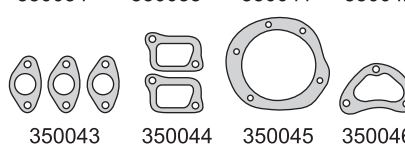

350034

350035

350041

350042

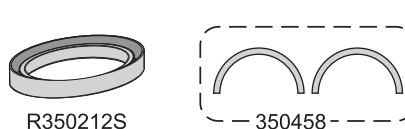

350043

350044

350045

350046

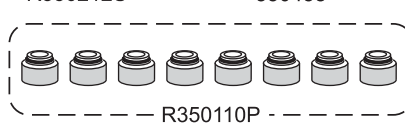

R350212S

350458



R350110P

M. BENZ

**MERCEDES
BENZ**



Motor/Engine	Cm³	HP	Ø
OM 321	5100	108	95

Mercedes Benz: MB 1112 - 1114 - 0140 - L1112
L1514 1957/...



DIESEL

Nº OE	Descripción/Description	Mat.	Ref.
	Jgo. de juntas para motor		350200-R
3120162220	Junta tapa cilindros Ø 96 ±1.40	NFT	1 350205
	Jgo. tornillos tapa cilindros (HAD19038)		B350300
3520160421	Junta tapa válvulas superior	NFT	1 350332
3520160421	Junta tapa válvulas superior	NH	350331
3520160421	Junta tapa válvulas superior	CG	350310
3525860301	Jgo. junta para cárter (4)	CG	1 350011
3520150320	Tapa distribución	CG	1 350012
3120150580	Placa distribución	NB	1 350013
3122010480	Tapa bomba de agua	NB	1 350014
3521420180	Jgo. múltiple escape (2)	NFT	1 350015
3524921080	Salida de escape	FCH	1 350018
3122010380	Placa bomba de agua	NB	1 350019
	Soporte bomba de agua	NB	1 350219
3121841079	Filtro aceite a block	NB	1 350027
3520180180	Llenado aceite motor	CG	1 350327
	Arandela doble raccord	CU	6 350032
3211310079	Base compresor aire Ø 77 mm.	NB	1 350034
3520150522	Junta tapa válvulas lateral	CG	1 350036
3211880179	Refrigerador aceite inferior	CB	1 350037
3121881479	Tapa refrigerador aceite superior	NB	1 350038
0090911280	Base bomba combustible	NB	1 350039
	Llenado aceite		350239
	Arandela refrigerador aceite	NB	16 350040
3211310279	Tapa cilindro compresor	NB	1 350042
	Tapa compresor	NB	1 350242
3522030680	Galería superior agua	NB	1 350043
3520760279	Soporte bomba inyectora	NB	1 350045
3120150680	Cierre distribución	CG	1 350046
	Jgo. juntas refrigerador aceite	VS	350048
	Juego juntas refrigeración P.P.	VS	1 350048B
	Jgo. juntas caja de velocidades G-27	CB	350050
	Jgo. juntas caja de velocidades G32	VS	350350
	Jgo. juntas diferencial eaton 161/162	VS	210155
	Núcleo diferencial Eaton 132 A y B (chico)	CB	350355
	Palier (16 agujeros)	AL	350257
0009979641	Jgo. empaquetadura cigüeñal (2)	SNA	1 350458
	Tapa diferencial simple	CG	350259
	Jgo. juntas compresor aire 77 mm.	VS	1 350359
3525860301	Jgo. junta para cárter (2)	CGT	350060
	Jgo. juntas motor electrónico Eaton	VS	210166
	Núcleo diferencial Eaton 132 A y B	CG	350368
	Tapa diferencial Eaton 161/162	CG	350369
	Tapa diferencial eaton 132 A y B (chico)	CG	350388
	O'ring camisa inyector G 30.8 x 3.7	GS	350840
	Anillo retorno inyector G 6.5 x 14 x 8	GS	
	Jgo. retén válvulas (12)	P	R350210P
0009975446	Retén distribución 65 x 90 x 15	S	1 R350212S

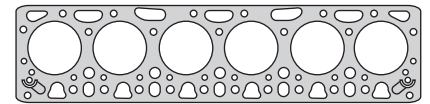

350205



350332

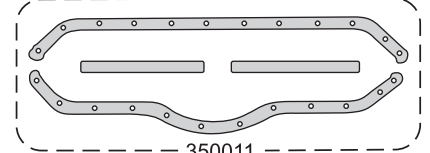

350011



350036

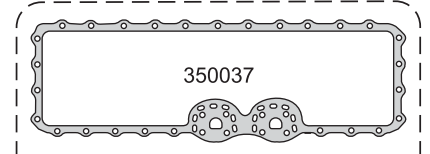

350037



350040



350038

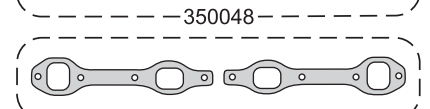

350048



350015



350012

350013

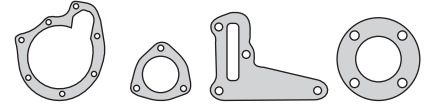

350014

350018

350019

350219



350027

350327

350032

350043

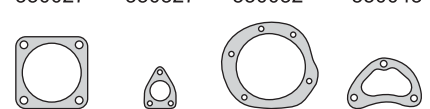

350242

350039

350045

350046

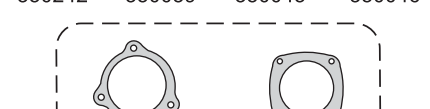

350034

350042

350359

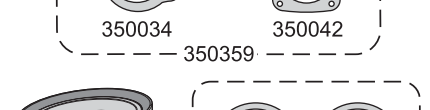

R350212S

350458



R350210P

M. BENZ

**MERCEDES
BENZ**



Motor/Engine	Cm³	HP	Ø
OM 352	5675	100	97

Mercedes Benz: MB 1114 - 0140 1972/...
OM 352 Turbinado 1981/...
OM 352 Aspirado 1981/...



DIESEL

Nº OE	Descripción/Description	Mat.	Ref.
3525861390	Jgo. de juntas para motor		350300-R
	Jgo. de juntas para motor		350301-R
	Jgo. de juntas superior		350395
3520160220	Junta tapa cilindros Ø 98.5 ±1.40	NFT 1 1	350305
	Jgo. tornillos tapa cilindros (HAD19038)		B350300
3520160421	Junta tapa válvulas superior	CG	350310
3520160421	Junta tapa válvulas superior	NB	350331
3520160421	Junta tapa válvulas superior	NFT 1 1	350332
3525860301	Jgo. junta para cárter (4)	CGT	350011
3520150320	Tapa distribución	CG	350012
3520150320	Tapa distribución	NB	350312
3120150580	Placa distribución	NB	350013
3522010480	Tapa bomba de agua	NB	350314
3521420180	Jgo. múltiple escape (2)	NFT 1 1	350015
3524921080	Salida de escape	FCH 1 1	350018
3522010980	Placa bomba de agua	NB	350319
	Llenado aceite	CG	350327
3520780080	Arandela doble raccord	CU 15 6	350032
3271840280	Filtro aceite a block	NB	350033
3211310079	Base compresor aire 77 mm.	NB	350034
3522030480	Carcaza termostato	NB	350035
3520150522	Junta tapa válvulas lateral	CG	350036
3211880179	Refrigerador aceite inferior	CB	350037
3121881479	Tapa refrigerador aceite superior	NB	350038
0090911280	Base bomba combustible	NB	350039
	Arandela radiador aceite	NB	350040
3522030780	Tapa carcaza termostato	NB 1 1	350041
	Junta vaso bomba de agua	CG 1	540041
3211310279	Cabeza cilindro compresor	NB	350042
3522030680	Galería superior agua	NB 2 2	350043
3522030080	Galería inferior agua	NB 2 2	350044
352076279	Soporte bomba inyectora	NB	350045
3120150680	Cierre distribución	CG	350946
	Kit de arandelas (83)	CU	350347
	Jgo. juntas refrigerador aceite	VS	350048
	Jgo. juntas refrigerador aceite P.P (18)	VS 1	350048B
	Jgo. juntas cañería refrigeración (6)	VS	350349
	Jgo. juntas caja velocidades G32	VS	350350
	Jgo. juntas diferencial Eaton 161/162	VS	210155
	Núcleo diferencial Eaton 132 chico	CB	350355
	Palier	AL	350257
	Jgo. empaquetaduras cigüeñal (2)	SNA	350458
	Jgo. juntas compresor aire 77 mm. (2)	VS	350359
3525860301	Jgo. junta para cárter (2)	CGT	350060
	Base compresor aire 94 mm.	NB	350463
	Tapa compresor aire 94 mm.	NFT	350464
	Jgo. juntas compresor aire 94 mm. (2)	VS	350465
	Jgo. juntas motor electrico Eaton	VS	210166
	Jgo. juntas compresor aire reforma	VS	350466
	Núcleo diferencial Eaton 161/162	CB	350467
	Tapa diferencial Eaton 161/162	CG	350369
	Kit de gomas (19)	GS	350375
	Tapa filtro aceite	GS	350376

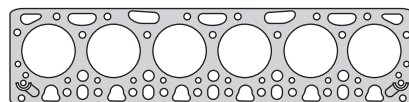

350305

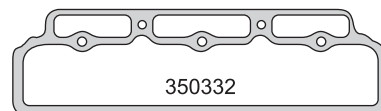

350332

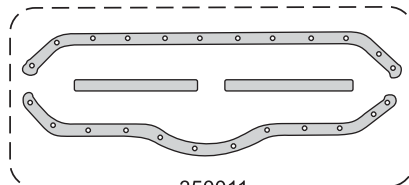

350011



350036

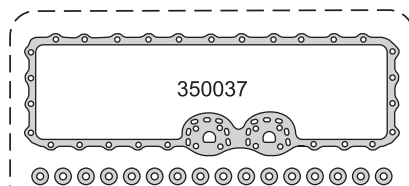

350037

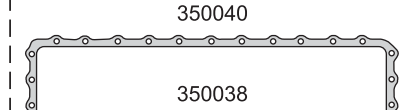

350040

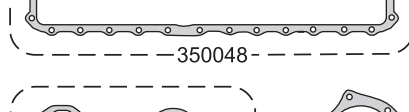

350038

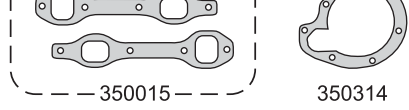

350015

350314



350012

350312

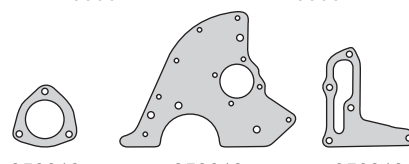

350018

350013

350319

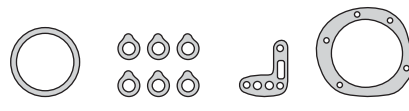

350327

350032

350033

350045



350039

540041

350946

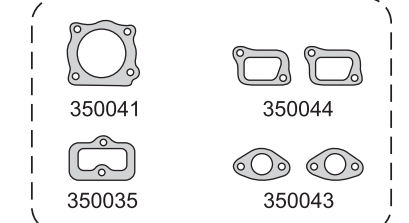

350041

350044

350035

350043

350349

M. BENZ

**MERCEDES
BENZ**



Motor/Engine	Cm³	HP	Ø
OM 352	5675	100	97

Mercedes Benz: MB 1114 - 0140 1972/...
OM 352 Turbinado 1981/...
OM 352 Aspirado 1981/...



DIESEL

Nº OE	Descripción/Description	Mat.	6	6	Ref.
	Tapón goma	GS			350377
	Núcleo diferencial Eaton 162 A y B	CB			350389
	Tapa diferencial Eaton 161/162	CG			350382
	Junta tapa cilindros competición	NFT			350390
	Arandela A 10 x 14 x 1 A	AL	6	6	
	Arandela A 18 x 24 x 1.5 A	AL		2	
	Arandela A 22 x 27 x 1.5 A	AL	1	1	
	Arandela A 24 x 32 x 1.5 A	AL		1	
	Arandela A 14 x 20 x 1.5 A	AL		18	
	Arandela A 8 x 12 x 1 Fe	F		16	
	Arandela A 10 x 20 x 1 C	CU	6	6	
	Arandela A 8 x 14 x 1 C	CU	6	10	
	Arandela A 11 x 15 x 1 C	CU		4	
	Arandela A 18 x 22 x 1.5 C	CU		3	
	Arandela A 16 x 22 x 1.5 C	CU		2	
	Arandela A 24 x 29 x 1.5 C	CU		1	
	Arandela A 14 x 18 x 1.5 A	AL		1	
	Arandela A 14 x 20 x 1.25 A	AL	4		
	Arandela A 16 x 22.5 x 1.5 A	AL		4	
	Arandela A 16 x 21 x 1.25 A	AL	4		
	Arandela B 26 x 32 x 3 CN	CN		1	
	Arandela B 24 x 32 x 3 CN	CN		1	
0169978248	O'ring camisa inyector G 30.5 x 3.5	GS	6	6	
	O'ring G 13.5 x 2.5	GS		1	
	O'ring G 8 x 2.4	GS		1	
	O'ring G 114.5 x 5	GS		1	
	O'ring G 61.8 x 3	GS		1	
	O'ring G 28 x 2	GS		1	
	Anillo G 95 x 104.2 x 3	GS		1	
	Anillo G 6.4 x 13.8 x 8	GS	7	7	
	Jgo. retén válvulas (12)	P			R350210P
	Ret. banc. refor. expansible 90 x 106 x 7.5	S			R350211-1S
	Retén distribución 65 x 90 x 15	S		1	R350212S

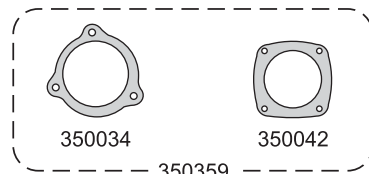

350359

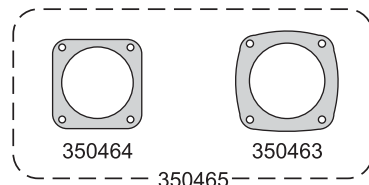

350465

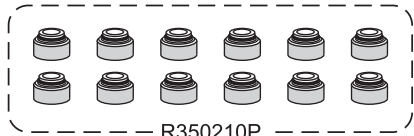
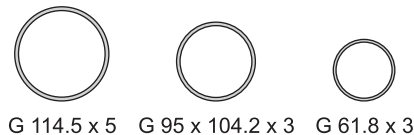
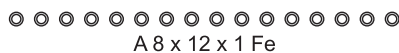

M. BENZ

MERCEDES BENZ



Motor/Engine	Cm³	HP	Ø
OM 352A	5675	130	97

Mercedes Benz: MB 1517 Turbo 0170 - L911
L1518 1978/...

DIESEL



Nº OE	Descripción/Description	Mat.	Ref.
	Jgo. de juntas para motor		350400-R
	Jgo. de juntas para motor		350401-R
	Jgo. de juntas superior		350495
3660160220	Jta. tapa cilindros Ø 98.5 ± 1.40	NFT	350405
3660160220	Jta. tapa cilindros Ø 98.5 ± 1.30	NFT 1 1	350407
	Jgo. tornillos tapa cilindros (HAD19038)		B350300
3520160421	Junta tapa válvulas superior	CG	350310
3520160421	Junta tapa válvulas superior	NB	350331
3520160421	Junta tapa válvulas superior	NFT 1 1	350332
3525860301	Jgo. junta para cárter (4)	CGT	350011
3520150320	Tapa distribución	CG	350012
3520150320	Tapa distribución	NB	350312
3120150580	Placa distribución	NB	350013
3522010480	Tapa bomba de agua	NB	350314
	Jgo. múltiple escape (2)	AC 1 1	350415
	Salida de escape	FCH 1 1	350418
3522010980	Placa bomba de agua	NB	350319
	Tubo llenado	CG	350327
	Base bomba nafta	NB	550628
3520780080	Arandela doble raccord	CU 15 6	350032
3271840280	Filtro aceite a block	NB	350033
3211310079	Base compresor aire 77 mm.	NB	350034
3522030480	Carcaza termostato	NB 1 1	350035
3520150522	Junta tapas válvulas lateral	CG	350036
3211880179	Refrigerador aceite inferior	CB	350037
3121881479	Tapa refrigerador aceite superior	NB	350038
0090911280	Base bomba combustible	NB	350039
	Arandela radiador aceite	NB	350040
	Jgo. juntas sobrealimentador GARRET (5)	VS	350440
3522030780	Tapa carcaza termostato	NB 1 1	350041
	Entrada aceite turbo	NB	350441
	Junta vaso bomba de nafta	CG 1	540041
3211310279	Cabeza cilindro compresor	NB	350042
3520980880	Turbina a codo colector	AC 1 1	350442
3522030680	Galería superior agua	NB 2 2	350043
3520980580	Codo admisión	NB 1 1	350443
3522030080	Galería inferior agua	NB 2 2	350044
3520180380	Brida cárter sobrealimentador	NB 1 1	350444
3520760279	Soporte bomba inyectora	NB	350045
3521870080	Cañería retorno aceite	NB 1	350445
3520150480	Cierre distribución	CG	350946
	Kit de arandelas (83)	VS	350347
	Jgo. juntas refrigerador aceite	VS	350048
	Jgo. juntas refrigerador aceite (18)	VS	350048B
3525860301	Jgo. juntas cañería refrigeración (6)	VS	350349
	Jgo. juntas caja de velocidades G-32	VS	350350
	Jgo. juntas caja de velocidades G-60	VS	350450
	Palier	CB	350456
	Jgo. empaquetadura cigüeñal (2)	SNA	350458
	Tapa diferencial	CG	350459
3525860301	Jgo. juntas compresor aire 77 mm. (2)	NB	350359
	Jgo. junta para cárter (2)	CGT	350060
	Colector a escape turbo	AC 1 1	350462

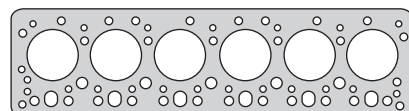

350407



350332

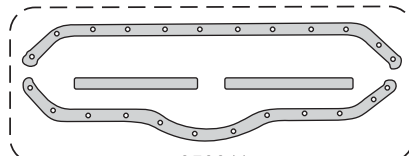

350011

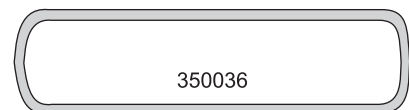

350036

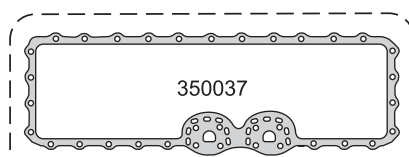

350037

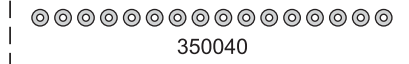

350040



350038

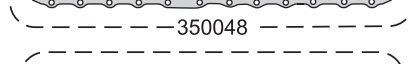

350048



350415

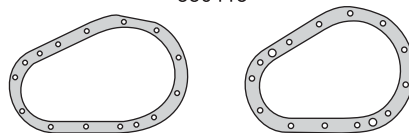

350012

350312

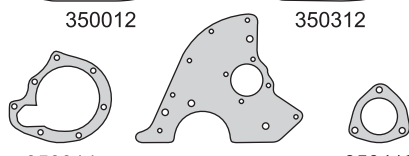

350314

350013

350418

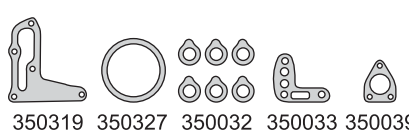

350319

350327

350032

350033

350039

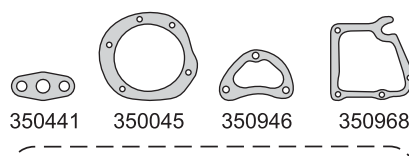

350441

350045

350946

350968

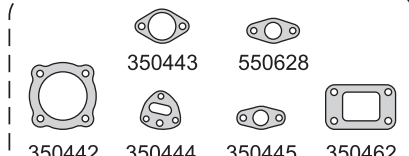

350443

550628

350442

350444

350445

350462

350440

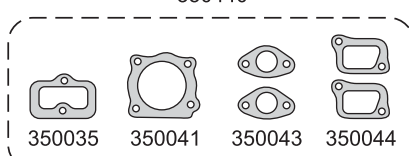

350035

350041

350043

350044

350349

M. BENZ

**MERCEDES
BENZ**



Motor/Engine **OM 352A** **5675** **130** **97**

Mercedes Benz: MB 1517 Turbo 0170 - L911
L1518 1978/...

DIESEL



Nº OE	Descripción/Description	Mat.	Ref.
	Base compresor aire 94 mm.	NB	1 350463
	Tapa compresor aire 94 mm.	NFT	1 350464
	Jgo. juntas compresor aire 94 mm. (2)	VS	1 350465
	Jgo. juntas compresor aire reforma	VS	350466
	Tapa diferencial	NH	350467
	Palier	NH	350468
	Base bomba de agua	NB	1 350968
	Kit de gomas (19)	GS	1 350375
	Tapa filtro aceite	GS	350376
	Tapón goma	GS	350377
	Junta tapa cilindros competición		350490
0169978248	O'ring camisa inyector G 30.5 x 3.5	GS	6 6
	Tubo retorno G 6.4 x 13.8 x 8	GS	7 7
	O'ring G 114.5 x 5	GS	1
	O'ring G 13.5 x 2.5	GS	1
	O'ring G 28 x 2	GS	1
	O'ring G 61.8 x 3	GS	1
	O'ring G 8 x 2.4	GS	1
	O'ring G 95 x 104.2 x 3	GS	1
	Arandela A 10 x 14 x 1 A	AL	6
	Arandela A 14 x 18 x 1.5 A	AL	1
	Arandela A 16 x 22.5 x 1.5 A	AL	4
	Arandela A 18 x 24 x 1.5 A	AL	2
	Arandela A 22 x 27 x 1.5 A	AL	1
	Arandela A 24 x 32 x 1.5 A	AL	1
	Arandela A 14 x 20 x 1.5 A	AL	18
	Arandela A 8 x 12 x 1 Fe	F	16
	Arandela A 10 x 20 x 1 C	CU	6 6
	Arandela A 8 x 14 x 1 C	CU	10
	Arandela A 11 x 15 x 1 C	CU	4
	Arandela A 18 x 22 x 1.5 C	CU	3
	Arandela A 16 x 22 x 1.5 C	CU	2
	Arandela A 24 x 29 x 1.5 C	CU	1
	Arandela B 26 x 32 x 3 CN	CN	1
	Arandela B 24 x 32 x 3 CN	CN	1
	Arandela A 16 x 21 x 1.25 A	AL	4
	Arandela A 10 x 14 x 1.25 A	AL	6
	Arandela A 22 x 28 x 1.25 A	AL	1
	Arandela A 8 x 13 x 1 C	CU	6
3469970445	Jgo. retén válvulas (12)	P	R350210P
	Ret. banc. refor. expansible 90 x 106 x 7.5	S	R350211-1S
	Retén distribución 65 x 90 x 15	S	1 R350212S

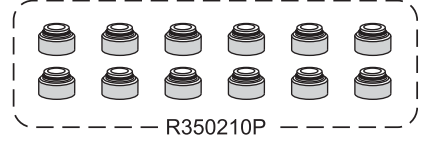
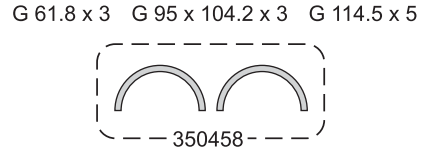
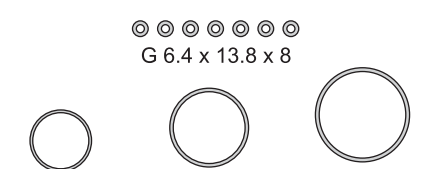
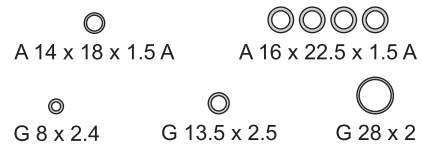
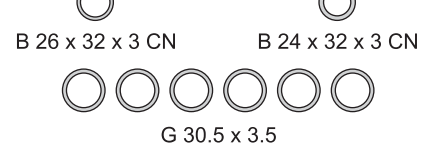
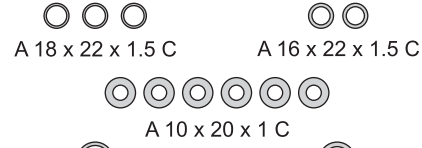
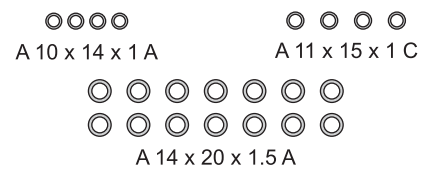
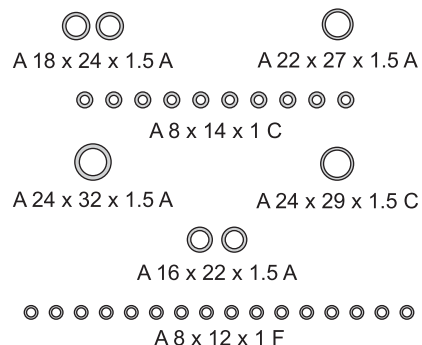
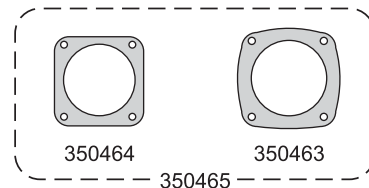
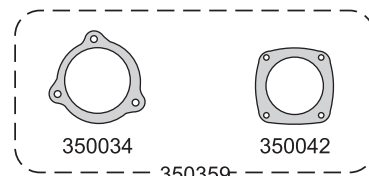

M. BENZ

**MERCEDES
BENZ**



Motor/Engine	Cm³	HP	Ø
OM 355-5 20V	9650	84	128

Mercedes Benz: MB 1521/1526 1985/87



DIESEL

Nº OE	Descripción/Description	Mat.	Ref.
	Jgo. de juntas para motor		350600-R
3450160221	Junta tapa cilindros Ø 130 \pm 1.30	NFT	350607-1
3460160320	Junta tapa cilindros Ø 130 \pm 1.30	NFT	1 350607-2
3550160220	Junta tapa cilindros Ø 130 \pm 1.30	NFT	1 350607-3
	Jgo. tornillos tapa cilindros (HAS19038)		B350600
3460160221	Junta tapa válvulas superior	NFT	5 350610
3562010180	Jgo. junta para cárter (4)	NB	1 350611
3460150120	Tapa distribución	CG	1 350612
3562010180	Cuerpo bomba de agua	NB	1 350614
3451427060	Múltiple escape	AC	5 350615
0664920080	Jgo. múltiple admisión (2)	NFT	1 350617
3551840480	Salida de escape	NFT	1 350718
3551840480	Termostato	NB	1 350619
3552010080	Bomba de aceite	NB	1 350627
3269970149	Cañería agua	NB	2 350629
0001846380	Cañería agua	NB	6 350630
3600770180	Arandela doble raccord A 8 x 12 x 1.5 C	CU	10 350032
3550150020	Junta tapa lateral válvulas	NB	1 350632
3560150121	Tacómetro	NB	1 350633
071511026008	Conducto de aceite	NB	1 350634
3600770180	Bomba inyectora	NB	2 350635
3550150020	Junta tapa válvulas lateral	NB	1 350636
3560150121	Tapa lateral cámara agua	NB	1 350637
3551880080	Cañería de aceite	NB	1 350638
071511040015	Compresor de aire a block	NB	1 350639
	Compresor de aire tapa válvulas	NB	1 350640
3530180180	Llenado aceite	CG	1 540041
	Compresor de aire entre cuerpo	NB	1 350641
3551880080	Bomba de aceite	NB	1 350642
071511040015	Entrada aire	NB	1 350643
	Bomba aceite	NB	1 350644
	Jgo. juntas compresor aire (3)	VS	1 350645
	Jgo. juntas caja de velocidades 1521	VS	350650
	Jgo. juntas caja de velocidades 1526	VS	350651
3520780080	Filtro de aceite		350657
	Jgo. empaquetadura cigüeñal (2)	SNA	350458
	Jgo. junta compresor turbo (5)	VS	1 590260
3030180079	Cañería aceite	NB	350662
	Junta turbina turbocompresor	AC	1 810162
	Junta base turbocompresor	AC	1 810163
	Junta retorno turbo	NB	1 810364
	Junta entrada aceite turbo	NB	1 810365
	Junta salida aceite turbo	NB	1 810366
	O'ring G 18 x 2	GS	1
3469970445	O'ring camisa inyector G 30 x 4	GS	6
	Arandela A 12 x 16 x 1.5 H	H	5
	Arandela A 8 x 17 x 1.5 H	H	18
	Arandela A 14 x 20 x 1.5 C	CU	12
	Arandela A 18 x 22 x 1.5 C	CU	2
	Arandela A 20 x 26 x 1.5 C	CU	2
	Arandela A 24 x 29 x 1.5 A	AL	2
	Arandela A 8.5 x 12 x 1.5 C	CU	10
	Arandela A 9.5 x 20 x 1 C	CU	5

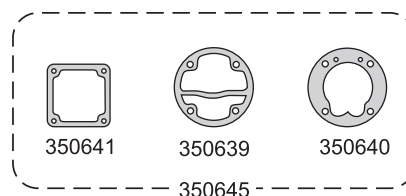
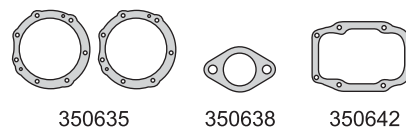
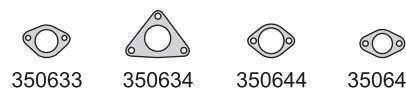
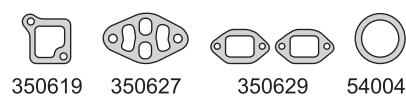
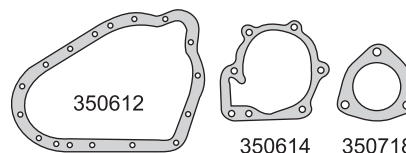
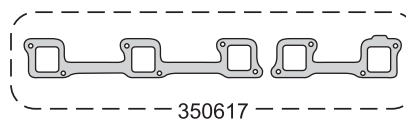
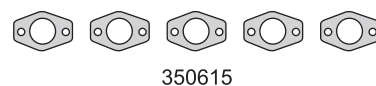
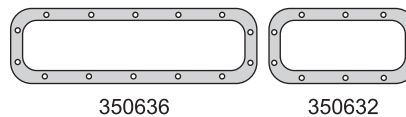
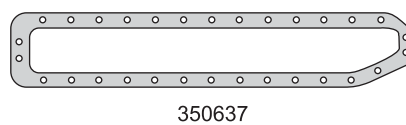
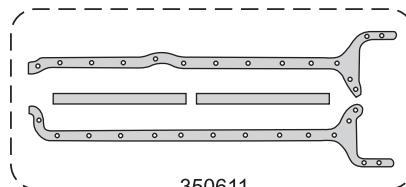
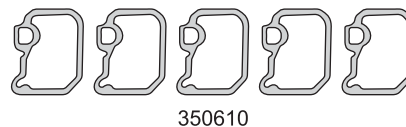
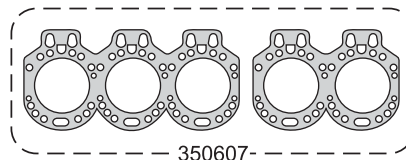

M. BENZ

**MERCEDES
BENZ**



Motor/Engine **OM 355-5 20V**
 Cm³ **9650**
 HP **84**
 Ø **128**

Mercedes Benz: MB 1521/1526 1985/87

DIESEL



Nº OE	Descripción/Description	Mat.	Ref.
	Arandela A 30 x 36 x 2 C	CU 1	
	Arandela A 30 x 36 x 2 A	AL 2	
	Arandela A 27 x 33.5 x 2 C	CU 1	
	Arandela A 20 x 24 x 1.5 C	CU 1	
	Arandela A16 x 22 x 1.5 C	CU 2	
	O´ring G 44.5 x 57 x 14	GS 5	
	O´ring G 48 x 62.5 x 16	GS 1	
	O´ring G 23.5 x 3	GS 2	
	O´ring G 28 x 2.5	GS 2	
	O´ring G 59 x 4	GS 2	
	Jgo. retén válvulas (20)	P 1	R350610P
	Retén distribución 75 x 100 x 12	S 1	R350612S

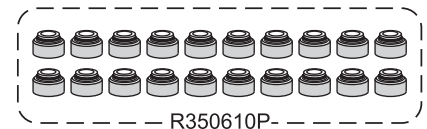
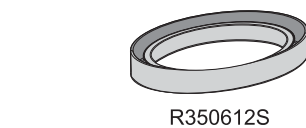
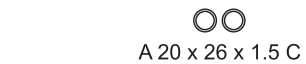
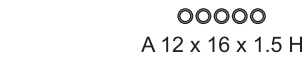
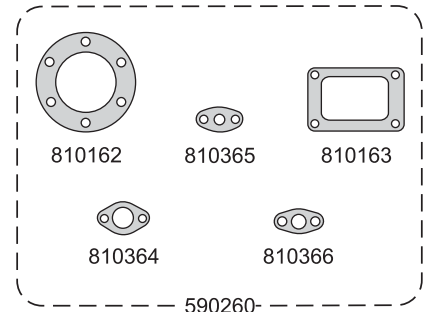

M. BENZ

**MERCEDES
BENZ**



Motor/Engine	Cm³	HP	Ø
OM 364	3971	90/115	97.5

Mercedes Benz: 711D - 811D - 609D
614D - 709D - 809D
OM364 Aspirado 1987/...



DIESEL

Nº OE	Descripción/Description	Mat.	Ref.
	Jgo. de juntas para motor		350800-R
3640160021	Jgo. de juntas para motor		350801-R
	Jgo. de juntas superior		350895
3640160320	Jta. tapa cilindros Ø 99 ± 1.40	NFT 1 1	350805
3640160320	Jta. tapa cilindros Ø 100 ± 1.40	NFT	350805-100
3640160320	Jta. tapa cilindros Ø 99 ± 1.40	NFT	350807
	Jgo. tornillos tapa cilindros (HAD19038)		B350100
3640101180	Junta tapa válvulas superior	NFT 1 1	350832
	Jgo. junta para cárter (4)	CG 1	350111
3660150020	Tapa distribución	NB 1	350312
3660150080	Placa distribución	NB 1	350013
3642010280	Bomba de agua	NB 1	350314
3661420180	Múltiple escape	AC 3 3	350815
3661410580	Múltiple admisión	NFT 2 2	350817
	Salida de escape	FCH	350818
3662030280	Caja termostato	NB 1 1	350919
3641040180	Base filtro aceite	NB 1	350127
3641840280	Base filtro aceite		350830
3520780080	Arandela tubería recuperación doble raccord	CU 4 4	350032
3640150180	Lateral a block	NB 1	350133
	Base compresor aire	NB 1	350034
4421870080	Tubería presión aceite	NB 1	350934
3640150160	Tapa lateral	GS 1	350836
	Junta refrigerador	NB	350837
	Base bomba combustible	NB 1	350839
3469970445	O'ring camisa inyector G 30.8 x 3.7	GS 4 4	350840
	Tapa termostato	NB 1 1	350041
	Anillo retorno inyector G 6.4 x 13.8 x 7.8	GS 5 5	350841
3662030380	Cañería agua a tapa	NB 2 3	350043
3660180380	Brida cárter sobrealimentador	NB	350444
	Soporte bomba inyectora	NB 1	350045
4421870180	Tubería retorno aceite	NB	350445
	Cierre distribución	CG 1	350946
	Jgo. empaquetadura cigüeñal	SNA 1	350458
	Jgo. junta para cárter (3)	CGT	350860
	Base compresor aire	NB	350463
3521310280	Tapa compresor aire	NFT 1	350464
	Jgo. juntas compresor aire (2)	VS	350465
	Arandela A 10 x 20 x 1 C	CU 4 4	
	Arandela A 16 x 22 x 1.5 A	AL 2 2	
	Arandela A 20 x 24 x 1.5 C	CU 1	
	Arandela A 20 x 24 x 1.5 A	AL 1	
	Arandela A 24 x 32 x 2 A	AL 1	
	Arandela A 8 x 14 x 1 C	CU 6 5	
	Arandela A 26 x 32 x 2 A	AL 1 1	
	O'ring G 13.94 x 2.62	GS 3	
	Jgo. retén válvulas (8)	P	R350110P
	Retén distribución 65 x 90 x 15	S 1	R350212S

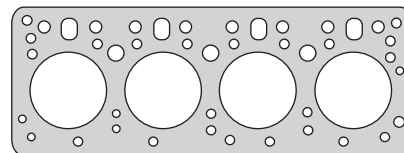

350805

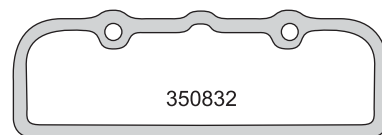

350832

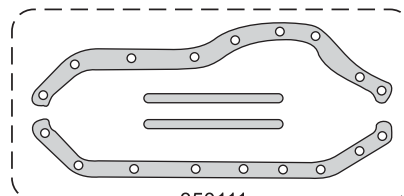

350111

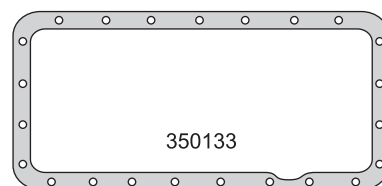

350133



350836

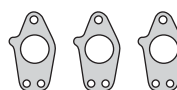

350815

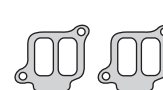

350817

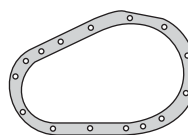

350312

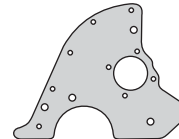

350013



350314



350818



350919



350127



350830



350032



350934



350839



350444



350034



350041



350043



350045



350464



350463



350946



350465



R350212S



350458



R350110P

M. BENZ

**MERCEDES
BENZ**



Motor/Engine	Cm³	HP	Ø
OM 366	5957	138	97.50
OM 366A/LA Euro Ecológico	5957	170	97.50

Mercedes Benz: OH1215/1315/1316/1319/1320
1420/1615-Aspirado Turbo 1620
OHL1621 - OS1318 - L1915
1314/1318/1365
2018/3611R
2214/2217



DIESEL

Nº OE	Descripción/Description	Mat.	Ref.
	Jgo. de juntas para motor		350900-R
3660160220	Jgo. de juntas para motor		350901-R
	Jgo. de juntas superior		350995
3660160220	Jta. tapa cilindros Ø 98.5 ± 1.40		350405
3660160220	Jta. tapa cilindros Ø 98.5 ± 1.30	NFT 1 1	350407
	Jgo. tornillos tapa cilindros (HAD19038)		B350300
3660160021	Junta tapa válvulas superior	NFT 1 1	350932
	Jgo. junta para cárter (4)	CGT 1	350960
3660150020	Tapa distribución	NB 1	350912
3660150080	Placa distribución	NB 1	350013
3642010280	Bomba de agua	NB 1	350314
3661420180	Múltiple escape	AC 4 4	350815
3661410580	Múltiple admisión	NFT 3 3	350817
	Salida de escape	FCH 1 1	350918
3662030280	Caja termostato	NB 1 1	350919
	Base bomba nafta	NB 1	550628
3662010180	Bomba agua a block	NH 1	350929
3760157217	Tapa distribución OM 366 LA	NB 1	350931
3520780080	Arandela doble raccord	CU 6 6	350032
3661840080	Filtro aceite a block	NB 1	350933
4421870180	Tubería presión aceite	NB 1	350934
3520150160	Tapa lateral	GS 1	350936
3661880780	Refrigerador aceite a block	NB 1	350937
3621881479	Tapa refrigerador aceite	NB 1	350938
0090911280	Base bomba combustible	NB 1	350839
3121881579	Arandela radiador aceite	NB 16	350040
0169978248	O'ring camisa inyector G 30.5 x 3.5	GS 6 6	350840
	Jgo. juntas sobrealimentador OM 366		350940
	Anillo retorno inyector G 5.4 x 13.8 x 7.8	GS 7 7	350841
	O'ring termostato base G 34 x 3	GS 2	350941
	Codo turbina	AC 1	350442
	Tapa distribución euro ecológico 00/...	NB	350942
3662030380	Cañería agua a tapa	NB 1 1	350043
	Codo admisión	NB 1 1	350443
	Cañería agua	NB 2 2	350943
3660180380	Brida cárter sobrealimentador	NB 1	350444
	Codo admisión	NB 1 1	350944
	Soporte bomba inyectora	NB 1	350045
4421870080	Cañería retorno aceite	NB	350445
	Jgo. juntas radiador aceite (18)	NB 1	350945
3520150480	Cierre distribución	CG 1	350946
	Kit arandelas (83)	CU 1	350347
	O'ring tapa termostato G 61.8 x 3	NB 1 1	350947
6004920080	Acople escape	FCH 1 1	350948
	Jgo. empaquetaduras cigüeñal	SNA 1	350458
3520140922	Jgo. junta para cárter (2)	CGT	350060
3520980208	Colector a escape turbo	AC 1 1	350462
3521310280	Base compresor aire	NB 1	350463
	Tapa compresor aire	NFT 1	350464
	Jgo. juntas compresor aire 90 (2)	VS 1	350465
	O'ring termostato G 60 x 4	GS 1 1	350965
	Bomba agua block	NB 1	350968
	Kit de gomas (28)	GS 1	350975

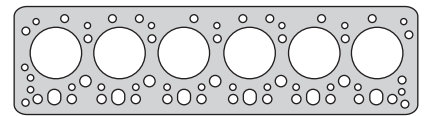

350407



350932

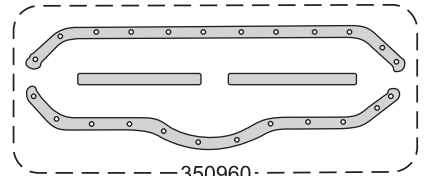

350960

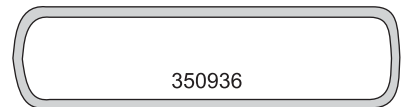

350936

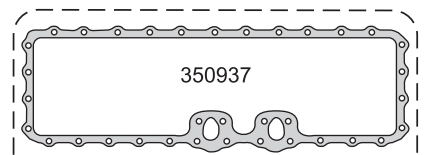

350937



350040

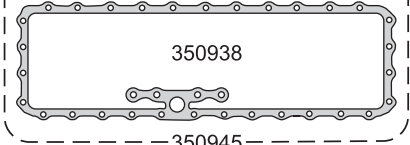

350938

350945

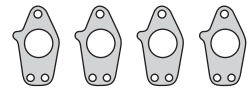

350815

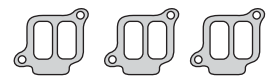

350817

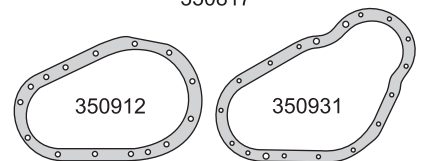

350912

350931

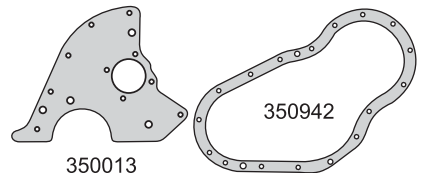

350013

350942

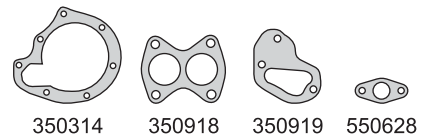

350314

350918

350919

550628

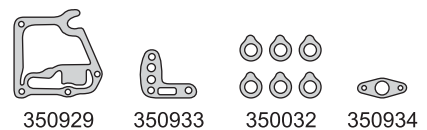

350929

350933

350032

350934

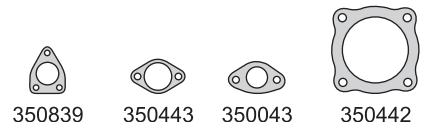

350839

350443

350043

350442

**MERCEDES
BENZ**



Motor/Engine	Cm³	HP	Ø
OM 366	5957	138	97.50
OM 366A/LA	5957	170	97.50
Euro Ecológico			
DIESEL			

Mercedes Benz: OH1215/1315/1316/1319/1320
1420/1615-Aspirado Turbo 1620
OHL1621 - OS1318 - L1915
1314/1318/1365
2018/3611R
2214/2217



Nº OE	Descripción/Description	Mat.	QTY	Ref.
	Tapa filtro aceite	GS	1	350376
	O´ring G 26.64 x 2.62	GS	1	
	O´ring G 119 x 3	GS	1	
3469970445	O´ring G 101 x 4	GS	1	
	O´ring G 28.2 x 2.5	GS	1	
	O´ring G 13.5 x 2.5	GS	1	
	O´ring G 33.5 x 4.2	GS	2	
	O´ring G 45 x 4	GS	2	
	O´ring G 61.8 x 3	GS	1	
	O´ring G 8 x 2.4	GS	4	
	O´ring G 75 x 3	GS	1	
	Arandela A 10 x 14 x 1 A	AL	6	6
	Arandela A 10 x 20 x 1 C	CU	6	6
	Arandela A 11 x 15 x 1 C	CU		4
	Arandela A 14 x 20 x 1.5 A	AL		18
	Arandela A 14 x 18 x 1.5 A	AL		1
	Arandela A 16 x 22 x 1.5 C	CU		2
	Arandela A 16 x 22.5 x 1.5 A	AL	4	4
	Arandela A 18 x 24 x 1.5 A	AL		2
	Arandela A 18 x 22 x 1.5 C	CU		3
	Arandela A 22 x 27 x 1.5 A	AL	1	1
	Arandela A 24 x 29 x 1.5 C	CU		1
	Arandela A 24 x 32 x 1.5 A	AL		1
	Arandela A 8 x 12 x 1 FE	FE		16
	Arandela A 8 x 14 x 1 C	CU	6	10
	Arandela B 26 x 32 x 3 CN	CN		1
	Arandela B 24 x 32 x 3 CN	CN		1
	Jgo. retén válvulas (12)	P		R350210P
	Retén distribución 65 x 90 x 15	S	1	R350212S

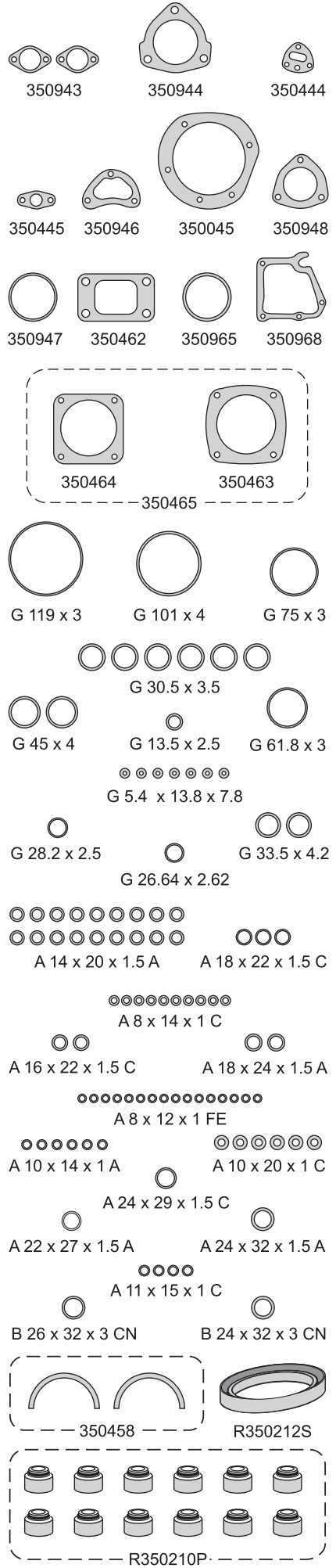

M. BENZ

**MERCEDES
BENZ**



Motor/Engine	Cm³	HP	Ø
OM 904 LA	4250	75/125	102
OM 904 LA IMO	4250	75/125	102
Electrónico 12V			

Mercedes Benz: Vario 614/814/815/810
Atego 712/714/715/717/720/812
814/815/817/917/1017/1214
1215/1217/1317
1517



DIESEL

Nº OE	Descripción/Description	Mat.	Ref.
9040102220	Jgo. de juntas para motor		351000-R
	Jgo. de juntas superior		351095
9040160620	Jta. tapa cilindros Ø 104 \pm 1.30	NFT	1 1 351007
9040161120	Jta. tapa cilindros Ø 103.5 \pm 1.20	MLS	351008
	Jgo. tornillos tapa cilindros (HAD19038)		B351000
9040160621	Conj. junta tapa válvulas (6)	N	1 351010
9040140622	Junta para cárter	NB	1 351011
9062010080	Bomba de agua	NB	1 351014
9061420280	Jgo. múltiple escape (2)	AC	1 1 351015
9061410180	Jgo. múltiple admisión (2)	SLS	1 1 351017
9062030180	Junta tuboladora bomba de agua	NB	1 351019
9061840280	Filtro aceite a block	GS	1 351027
9060910380	Base bomba combustible	SLS	1 351028
0020941580	Filtro combutible	GS	1 351031
0000160421	Conj. junta tapa válvulas (plástico) (6)	GS	1 1 351032
	Arandela tapa válvulas	GS	5 5 351033
	Junta lateral tapa de válvulas	GS	1 351036
0001883280	Tapa refrigerador aceite	GS	1 351037
9041880280	Radiador aceite	NB	1 351038
9060980480	Tubo aire sobrealimentador	SLS	1 351039
0800180480	Difusor aceite en tapa válvula		351040
	Junta turbo	AC	351042
	Junta turbo	NB	351044
	Junta turbo	AC	351045
6703510085	Tapa diferencial (CE)	CG	350159
	Junta asiento delgas compresor	NFT	1 351062
	Junta tapa válvulas compresor	NFT	1 351063
	Junta tapa cilindros compresor	AL	1 351064
00013658015	Jgo. juntas compresor (5)	VS	1 351065
	Jgo. juntas turbo (5)	VS	1 351068
	Junta tapa cilindros	MLS	351090
	Arandela A 12 x 18 x 1 C	CU	1
	Arandela A 10 x 14 x 1 C	CU	1
	O'ring compresor G 88.57 x 2.62	GS	1
	O'ring compresor G 117.07 x 3.53	GS	1
	Kit de retenes completo		R351000
	Jgo. retén válvulas (12)	V	1 R351010V
	Retén bancada 115 x 140 x 13	VF	1 R351011VF
	Retén distribución 78 x 104 x 11	VF	1 R351012VF

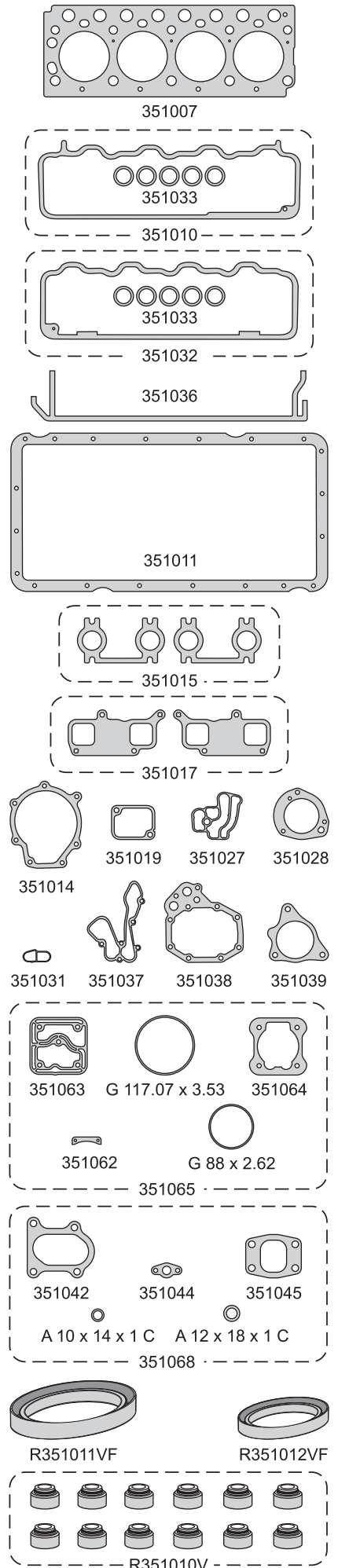

M. BENZ

MERCEDES BENZ



Motor/Engine	Cm³	HP	Ø
OM906 LA OM906.911/919 920/921/922/923 Electrónico 18V	6370	231 245/279	102

Mercedes Benz: Atego I 925/1225/1228/1325
1328/1525/1528/1823/1828
2523/2528/2628 1998/...



DIESEL

Nº OE	Descripción/Description	Mat.		Ref.
	Jgo. de juntas para motor			352000-R
9060101721	Jgo. de juntas superior		●	352095
9060161220	Jta. tapa cilindros Ø 103.5 \pm 1.30	MLS	1	352008
9060160769	Jgo. de tornillos para tapa de cilindros			B352000
9060160621	Conj. junta tapa válvulas (8)	GS	1	302010
9060140422	Junta para cárter	NB	1	352011
9062010080	Bomba de agua	NB	1	351014
9061400280	Jgo. múltiple escape (3) 351015/1	AC	1	352015
9061410480	Jgo. múltiple admisión (3) 351017/1	SLS	1	352017
9062030180	Junta tubuladora bomba de agua	NB	1	351019
9061840280	Junta filtro aceite a block	GS	1	351027
9060910780	Junta base bomba combustible	SLS	1	351028
0020941580	Junta filtro combustible	GS	1	351031
0000160521	Conj. junta tapa válvulas (8)	GS	1	352032
9060160080	Arandelas especiales tapa de válvulas	AC/GS	6	351033
9063320080	Junta adaptador superior volante			352034
	Junta lateral tapa de válvulas	GS	1	352036
4420150980	Junta inspección inferior volante			352037
9061880280	Junta radiador aceite	NB	1	352038
0000180133	Junta especial diafragma tapa de válvulas	GS		352039
	Junta tapa cilindros importada	MLS		352090
0249972148	O´ring G 117.07 x 3.53	GS	1	
0289975648	O´ring G 39.34 x 2.62	GS	6	
0289975648	O´ring G 36.17 x 2.62	GS	6	
0239976848	O´ring G 9.19 x 2.62	GS	6	
	O´ring G 16 x 4	GS	1	
	Arandela A 20 x 26 x 1.5 C	CU	1	
	Arandela A 18 x 24 x 1.5 C	CU	1	
	Arandela A 16 x 22 x 1.5 A	AL	1	
	Arandela A 14 x 20 x 1.5 A	AL	1	
	Arandela inyector A 10 x 14 x 1 C	CU	6	
	Kit de retenes completo			R352000
3660530058	Jgo. retén válvulas (18)	V	1	R352010V
0229977647	Retén distribución 78 x 104 x 11	VF	1	R351012VF
0259975047	Retén bancada 115 x 140 x 13	VF	1	R351011VF

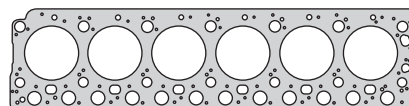

352008

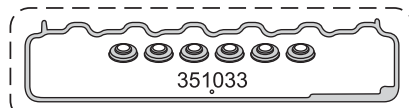

351033

352010

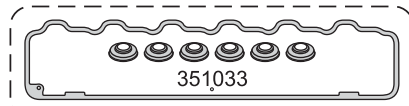

351033

352032

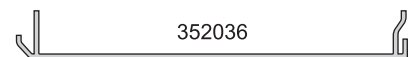

352036

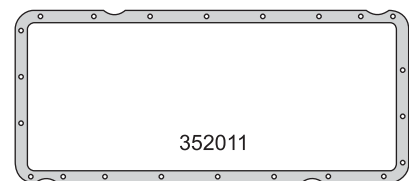

352011

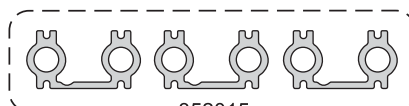

352015

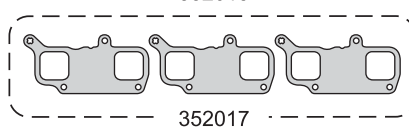

352017

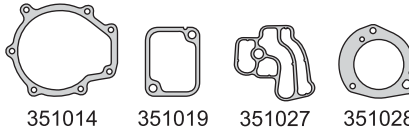

351014

351019

351027

351028

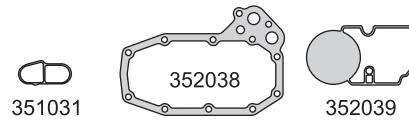

351031

352038

352039

G 16 x 4

A 20 x 26 x 1.5 C

A 18 x 24 x 1.5 C



G 36.17 x 2.62

G 9.19 x 2.62

A 10 x 14 x 1 C



G 39.34 x 2.62

A 16 x 22 x 1.5 A

A 14 x 20 x 1.5 A

G 117.07 x 3.53



R351012VF

R351011VF

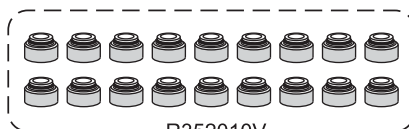

R352010V

M. BENZ





















































**MERCEDES
BENZ****taranto**Motor/Engine  **Motor/Engine****Cm³****HP****Ø****OM 352**
OM 352A Turbo

5675

130

97

Mercedes Benz: MB 1518 1991/... Motor Híbrido
Con junta tapa lateral de goma**DIESEL**

Nº OE	Descripción/Description	Mat.	Ref.
	Jgo. de juntas para motor 	●	352200-R
3660160220	Jta. tapa cilindros Ø 98.5 ± 1.40 	NFT	350405
3660160220	Jta. tapa cilindros Ø 98.5 ± 1.30 	NFT	1 350407
	Jgo. tornillos tapa cilindros (HAD19038) 		B350300
3525860301	Jgo. junta para cárter (4) 	CG	1 350011
3520150320	Tapa distribución 	NB	1 350312
3120150580	Placa distribución 	NB	1 350013
3522010480	Tapa bomba de agua 	NB	1 350314
	Jgo. múltiple escape (2) 	AC	1 350415
	Salida de escape 	FCH	1 350418
3522010980	Placa bomba de agua 	NB	1 350319
	Junta bomba de agua 	NB	1 352219
	Base bomba nafta 	NB	1 550628
3520780080	Arandela doble raccord 	CU	6 350032
3520160421	Junta tapa válvulas 	NFT	1 350332
3271840280	Filtro aceite a block 	NB	1 350033
3211310079	Base compresor aire 77 mm.	NB	1 350034
	Junta tubería aceite 	NB	1 350934
3522030480	Carcasa termostato 	NB	1 350035
3520150160	Junta tapa lateral 	GS	1 350936
3661880780	Refrigerador aceite a block 	NB	1 350937
3121881479	Tapa refrigerador aceite superior 	NB	1 350038
	Arandela radiador aceite 	NB	16 350040
	Jgo. juntas sobrealimentador GARRET (5) 	VS	1 350440
3522030780	Tapa carcasa termostato 	NB	1 350041
	Entrada aceite turbo 	NB	1 350441
	Junta vaso bomba combustible 	CG	1 540041
3211310279	Cabeza cilindro compresor 	NB	1 350042
3520980880	Turbina a codo colector 	AC	1 350442
3522030680	Galería superior agua 	NB	2 350043
3520980580	Codo admisión 	NB	1 350443
3522030080	Galería inferior agua 	NB	2 350044
3520180380	Brida cárter sobrealimentador 	NB	1 350444
	Codo admisión 	NB	1 350944
3520760279	Soporte bomba inyectora 	NB	1 350045
3521870080	Cañería retorno aceite 	NB	1 350445
3520150480	Cierre distribución 	CG	1 350946
	Kit de arandelas (83) 	VS	1 350347
3525860301	Jgo. juntas cañería refrigeración (6) 	VS	1 350349
	Jgo. empaquetadura cigüeñal (2) 	SNA	1 350458
3525860301	Jgo. juntas compresor aire 77 mm. (2) 	VS	1 350359
	Jgo. junta para cárter (2) 	CGT	1 350060
	Colector a escape turbo 	AC	1 350462
	Base compresor aire 94 mm. 	NB	1 350463
	Tapa compresor aire 94 mm. 	NFT	1 350464
	Jgo. juntas compresor aire 94 mm. (2) 	VS	1 350465
	Base bomba de agua 	NB	1 350968
	Kit de gomas (19) 	GS	1 350375
0169978248	O'ring camisa inyector G 30.5 x 3.5 	GS	6
	Tubo retorno G 6.4 x 13.8 x 8 	GS	7
	O'ring G 114.5 x 5 	GS	1
	O'ring G 13.5 x 2.5 	GS	1
	O'ring G 28 x 2 	GS	1

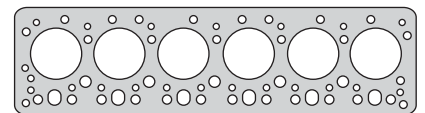

350407



350332

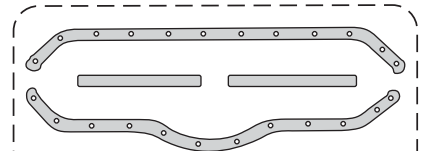

350011



350936

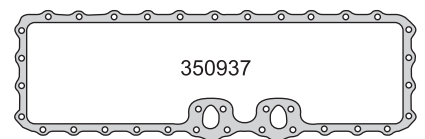

350937



350038

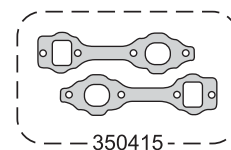

350415

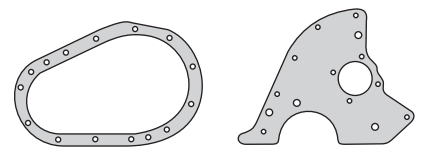

350312

350013



350314

350418

350319

352219

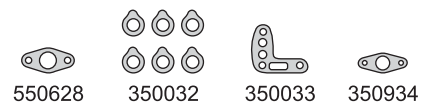

550628

350032

350033

350934

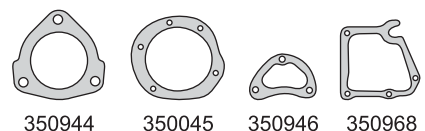

350944

350045

350946

350968



350441

350040

540041

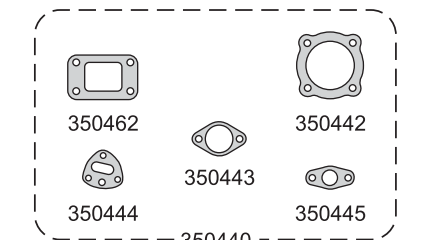

350462

350442

350444

350443

350445

350440

MERCEDES BENZ



Motor/Engine	Cm³	HP	Ø
OM 352 OM 352A Turbo	5675	130	97

Mercedes Benz: MB 1518 1991/... Motor Híbrido
Con junta tapa lateral de goma



DIESEL

Nº OE	Descripción/Description	Mat.	Ref.
	O´ring G 61.8 x 3	GS	1
	O´ring G 8 x 2.4	GS	1
	O´ring G 95 x 104.2 x 3	GS	1
	Arandela A 10 x 14 x 1 A	AL	6
	Arandela A 18 x 24 x 1.5 A	AL	2
	Arandela A 22 x 27 x 1.5 A	AL	1
	Arandela A 24 x 32 x 1.5 A	AL	1
	Arandela A 14 x 20 x 1.5 A	AL	18
	Arandela A 8 x 12 x 1 Fe	FE	16
	Arandela A 10 x 20 x 1 C	CU	6
	Arandela A 8 x 14 x 1 C	CU	10
	Arandela A 11 x 15 x 1 C	CU	4
	Arandela A 14 x 18 x 1.5 A	AL	1
	Arandela A 16 x 22.5 x 1.5 A	AL	4
	Arandela A 18 x 22 x 1.5 C	CU	3
	Arandela A 16 x 22 x 1.5 C	CU	2
	Arandela A 24 x 29 x 1.5 C	CU	1
	Arandela B 26 x 32 x 3 CN	CN	1
	Arandela B 24 x 32 x 3 CN	CN	1
3469970445	Jgo. retén válvulas (12)	P	R350210P
	Retén distribución 65 x 90 x 15	S	R350212S

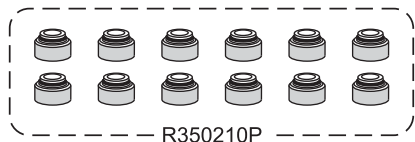
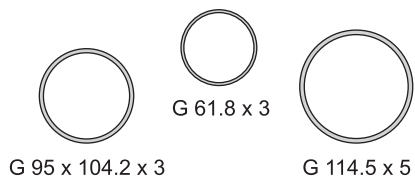
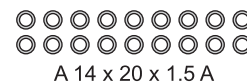
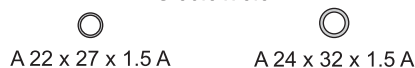
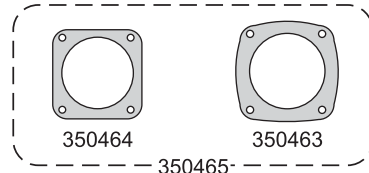
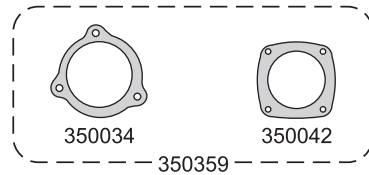
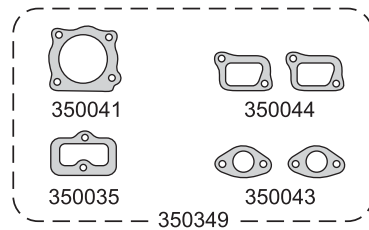

**MERCEDES
BENZ**



Motor/Engine	Cm³	HP	Ø
OM 449A/LA/HLA	9973	180/200	128

Mercedes Benz: 1630 - 1632 - 1633 - MB485.980
 MB489.960/961-MB475.907/950
 MB954/976/979/982/984/986
 989/991/994/997
 998



DIESEL

Nº OE	Descripción/Description	Mat.	Ref.
	Jgo. de juntas para motor		360000-R
	Jgo. de juntas para motor		360001
	Jgo. de juntas superior (1 cilindro)		360095
4220160420	Jta. tapa cilindros Ø143.5 ± 1.30 N.R. (HAS17038)	ACG 1 5	360008
	Jgo. tornillos tapa cilindros (HAS17038)		B360000
4030160321	Junta tapa válvulas superior	NB 1 5	360010
4050140222	Jgo. junta para cárter (4)	NB 1	360011
4290150080	Tapa distribución	NB 1	360012
4030110080	Tapa delantera block	NB 1	360013
4032011080	Bomba de agua	NB 1	360014
40314220380	Múltiple escape	AC 5 5	360015
4421410480	Multiple admisión	NFT 5 5	360017
4071310880	Tapa compresor 0.80	NB 1	360027
4071310880	Tapa compresor 0.50	NB 1	360027/1
	Tapa compresor	NB 1	360327
	Base bomba nafta	NB 1	550628
4422010480	Bomba de agua	NB 1	360029
917003040003	Acople lateral	NB 1	360030
917003036002	Base bomba aceite	NB 1	360030/1
4030180180	Llenado cárter	NB 1	360031
6171870180	Entrada aceite	NB 1	360032
	Pico inyector	GS 5	360033
4031840280	Refrigerador aceite	NB 1	360038
4031310780	Carcasa inferior compresor superior	NB 1	360039
4071310780	Tapa compresor	NB 1	360040
4750880280	Colector admisión	NB 1	360041
4750980380	Admisión entrada	NB 1	360042
917003026000	Refrigerador aceite	NB 2	360043
3521870080	Codo admisión	NB 1	350443
3520980580	Salida aceite	NB	350445
4750150180	Cierre distribución	CG 1	360046
007603026305	Arandela tapón cárter A 26 x 34 x 2 A	AL 1	360048
	Arandela A 10 x 20 x 1 C	CU 1	
4230110284	Suplemento camisa cilindros - 1 boca (0.08)	CHA	360070-0.08
4230110084	Suplemento camisa cilindros - 1 boca (0.10)	CHA	360070-0.10
4230110184	Suplemento camisa cilindros - 1 boca (0.15)	CHA	360070-0.15
	Kit de retenes completo		R360000
	Jgo. retén válvulas (10)	P 1	R360010P
0139971447	Retén bancada 120 x 140 x 13	V 1	R360011V
0149974647	Retén distribución 105 x 130 x 12	V 1	R360012V

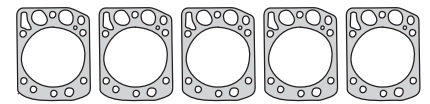

360008



360010

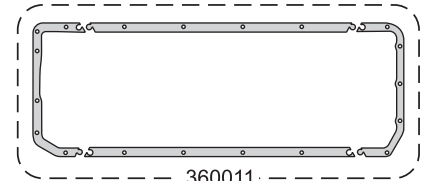

360011

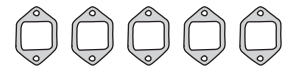

360015



360017

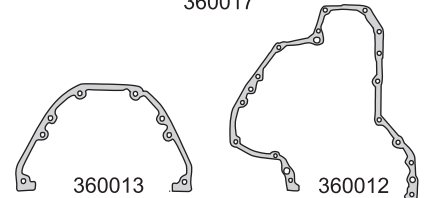

360013

360012

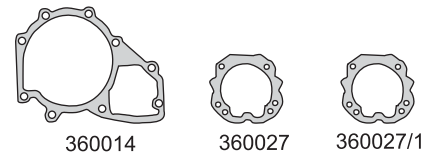

360014

360027

360027/1



360327

360029

360030



360030/1

360031

360039

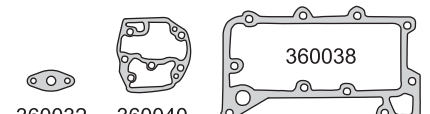

360032

360040

360038

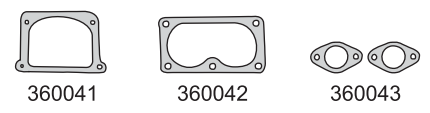

360041

360042

360043

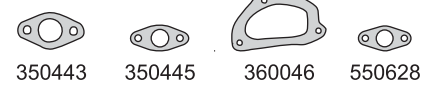

350443

350445

360046

550628



A 26 x 34 x 2 A

A 10 x 20 x 1 C



R360011V

R360012V

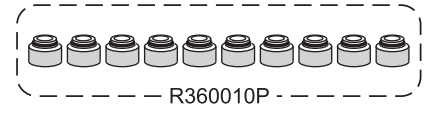

R360010P

M. BENZ

MERCEDES BENZ



Motor/Engine	Cm³	HP	Ø
OM 616.912	2404	65	91
OM 616.934/960	2404	65	91
OM 616.916/940	2404	72	91
OM 616.961/963	2404	72	91

Mercedes Benz: 240D/TD 1973/... - 207/307D
 407/507/510D - L406/407DG
 0309D 1977/... - 240GD 76/87
 MB100/200/300/400/180D
 MB150/170



DIESEL

Nº OE	Descripción/Description	Mat.	Ref.
	Jgo. de juntas para motor		360100-R
6210100321	Junta tapa cilindros Ø 92 \pm 1.70	NFT 1	360107
	Jgo. tornillos tapa cilin. (HAN12055/HAN12100)		B360100
6150160080	Junta tapa válvulas	N 1	360110
	Jgo. junta para cárter (3)	NB 1	360111
6211421180	Múltiple admisión y escape	NFT 1	360116
	Base filtro aceite	NB 1	360128
	Intercambiador	NB 1	360129
	Bomba hidráulica	NB 1	360130
	Bomba vacío	NB 2	360131
	Termostato	NB 1	360132
	Tensor hidráulico	NB 1	360133
	Acople termostato	NB 1	360134
	Junta	NB 1	360135
	Cuerpo aceite	NB 1	360137
	Junta	NB 1	360138
	Junta	NB 1	360139
	Junta	NB 1	360140
0019971241	Retén cigüeñal	SNA 1	360158
	Arandela A 28 x 34 x 1.5 A	AL 4	
	Arandela A 26 x 32 x 2 A	AL 2	
	Arandela A 14 x 18 x 1.5 A	AL 1	
	O'ring G 25.07 x 2.62	GS 1	
	O'ring G 7.59 x 2.62	GS 1	
	O'ring G 6.07 x 1.78	GS 2	
	Kit de retenes completo		R360100
	Jgo. retén válvulas (8)	P 1	R360110P
0119972247	Retén distribución 45 x 74.5/79.5 x 12/14.5	P 1	R360112P

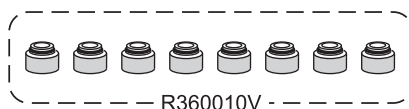
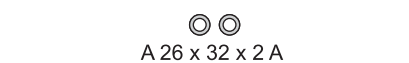
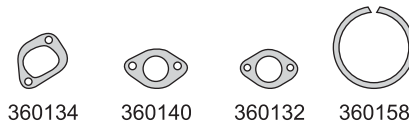
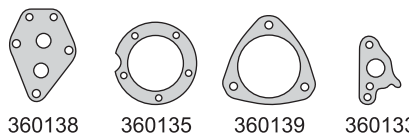
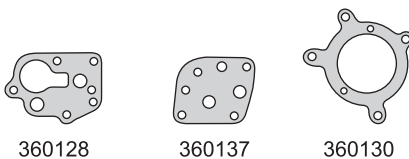
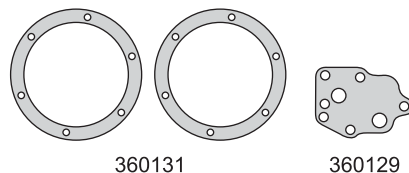
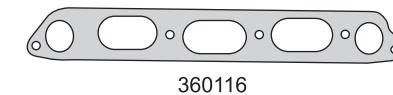
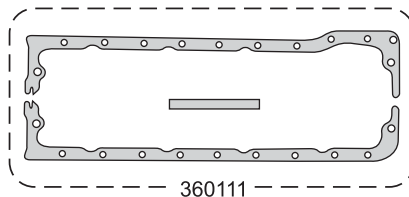
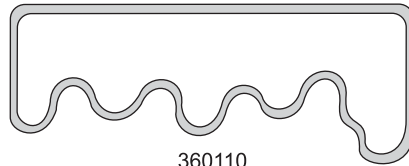
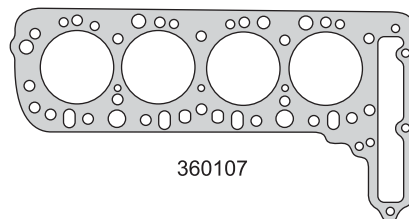

M. BENZ

MERCEDES BENZ

taranto

Motor/Engine **Cm³** **HP** **Ø**
OM352
OM352A **5675** **97**
Mercedes Benz: Turbinado - Aspirado 1981/...

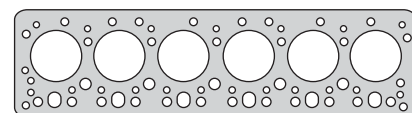
DIESEL

350405

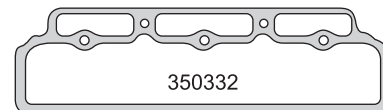

350332

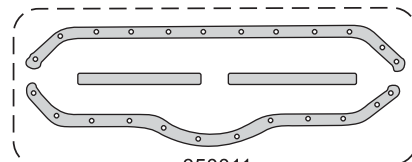

350011

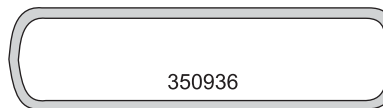

350936

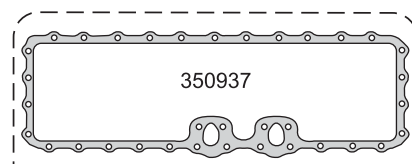

350937



350040

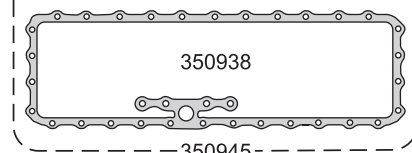

350938

350945

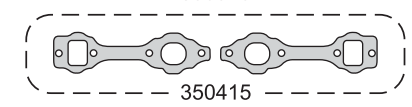

350415

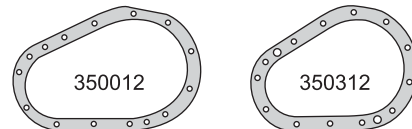

350012

350312

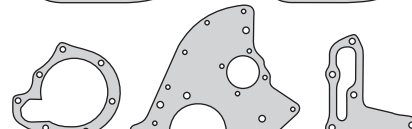

350314

350013

350319

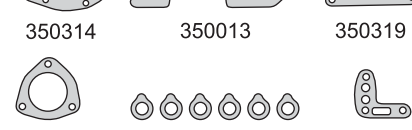

350018

350032

350033

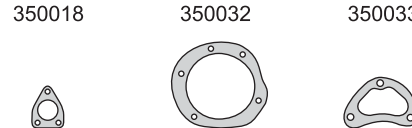

350039

350045

350046

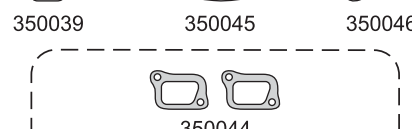

350044

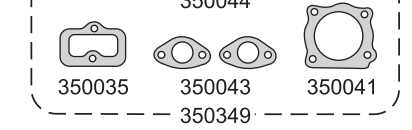

350035

350043

350041

350349

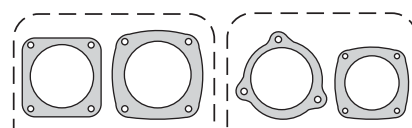

350464

350463

350034

350042

350465

350359

Nº OE	Descripción/Description	Mat.	Ref.
	Jgo. de juntas para motor		360200
	Junta tapa cilindros Ø 98.5 ± 1.40	NFT 1	350405
	Junta tapa cilindros Ø 98.5 ± 1.30	NFT 1	350407
	Jgo. tornillos tapa cilindros (HAD19038)		B350300
	Jgo. junta para cárter (4)	CG 1	350011
	Tapa distribución	CG 1	350012
	Tapa distribución	NB 1	350312
	Placa distribución	NB 1	350013
	Bomba de agua	NB 1	350314
	Jgo. múltiple escape (2)	AC 1	350415
	Salida de escape	FCH 1	350018
	Placa bomba de agua	NB 1	350319
	Junta tapa válvulas	NFT 1	350332
	Arandela doble raccord A 8 x 12 x 1.5 C	CU 6	350032
	Filtro aceite a block	NB 1	350033
	Junta cilindro compresor aire	NB 1	350034
	Carcaza termostato	NB 1	350035
	Lateral botadores	GS 1	350936
	Refrigerador aceite block	NB 1	350937
	Tapa refrigerador aceite	NB 1	350938
	Base bomba combustible	NB 1	350039
	Arandela radiador aceite	NB 16	350040
	Tapa carcaza termostato	NB 1	350041
	Junta cabeza cilindro compresor	NB 1	350042
	Galería superior agua	NB 2	350043
	Galería inferior agua	NB 2	350044
	Soporte bomba inyectora	NB 1	350045
	Jgo. juntas radiador aceite (18)	VS 1	350945
	Cierre distribución	CG 1	350046
	Kit arandelas (71)	VS 1	350347
	Jgo. juntas cañería refrigeración (6)	VS 1	350349
	Jgo. juntas compresor aire 77 mm. (2)	VS 1	350359
	Jgo. juntas para cárter (2)	CGT	350060
	Base compresor 0.4 mm	NB 1	350463
	Tapa compresor aire 94 mm.	NFT 1	350464
	Jgo. juntas compresor aire 94 mm. (2)	VS 1	350465
	Arandela A 10 x 14 x 1 A	AL 6	
	Arandela A 10 x 20 x 1 C	CU 6	
	Arandela A 11 x 15 x 1 C	CU 4	
	Arandela A 14 x 20 x 1.5 A	AL 18	
	Arandela A 16 x 22 x 1.5 C	CU 2	
	Arandela A 18 x 24 x 1.5 A	AL 2	
	Arandela A 18 x 22 x 1.5 C	CU 3	
	Arandela A 22 x 27 x 1.5 A	AL 1	
	Arandela A 24 x 29 x 1.5 C	CU 1	
	Arandela A 24 x 32 x 1.5 A	AL 1	
	Arandela A 8 x 12 x 1 FE	FE 16	
	Arandela A 8 x 14 x 1 C	CU 10	
	Arandela A 14 x 18 x 1.5 A	AL 1	
	Arandela A 16 x 22.5 x 1.5 A	AL 4	
	Arandela B 26 x 32 x 3 CN	CN 1	
	Arandela B 24 x 32 x 3 CN	CN 1	

**MERCEDES
BENZ**



Motor/Engine **Cm³** **HP** **Ø**

OM 447-6 **11967** **250/300** **128**

Mercedes Benz: O372 - O400 - L1395
1939 - 1941 1973/...

DIESEL



Nº OE	Descripción/Description	Mat.	Ref.
	Jgo. de juntas para motor	●	360300-R
	Jgo. de juntas para motor		360301-R
4220160420	Junta tapa cilindros Ø 143.5 ± 1.30 N.R. HAS17038	ACG 6	360008
	Jgo. tornillos tapa cilindros (HAS17038)		B360000
4030160321	Junta tapa válvulas superior	NB 6	360010
070140222	Jgo. junta para cárter (4)	NB 1	360311
4290150080	Tapa distribución	NB 1	360012
4030110080	Tapa delantera block	NB 1	360013
4032011080	Bomba de agua	NB 1	360014
40314220380	Múltiple escape	AC 6	360015
4421410480	Múltiple admisión	NFT 6	360017
4071310880	Tapa compresor 0.80	NB 1	360027
4071310880	Tapa compresor 0.50	NB 1	360027/1
	Tapa compresor	NB 1	360327
	Base bomba nafta	NB 1	550628
4422010480	Bomba de agua	NB 1	360029
917003040003	Acople lateral	NB 1	360030
917003036002	Base bomba aceite	NB 1	360030/1
4030180180	Llenado cárter	NB 1	360031
6171870180	Entrada aceite	NB 1	360032
4031840280	Refrigerador aceite	NB 1	360038
4031310780	Carcasa inferior compresor superior	NB 1	360039
4071310780	Tapa compresor	NB 1	360040
	Colector admisión	NB 1	360041
	Admisión entre múltiples	NB 1	360042
917003026000	Refrigerador aceite	NB 2	360043
3521870080	Salida aceite	NB 1	350443
4750150180	Cierre distribución	CG 1	360046
007603026305	Arandela tapón cárter A 26 x 32 x 2 A	AL 1	360048
4230110284	Suplemento camisa cilindros - 1 boca (0.08)	CHA	360070-0.08
4230110084	Suplemento camisa cilindros - 1 boca (0.10)	CHA	360070-0.10
4230110184	Suplemento camisa cilindros - 1 boca (0.15)	CHA	360070-0.15
	Kit de retenes completo		R360300
4220530196	Jgo. retén válvulas (12)	P 1	R360010P
0139971447	Retén bancada 120 x 140 x 13	V 1	R360011V
0149974647	Retén distribución 105 x 130 x 12	V 1	R360012V

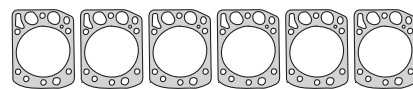

360008



360010

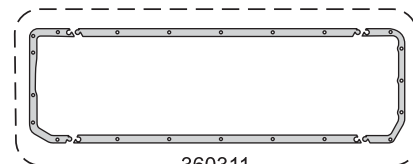

360311



360012



360015

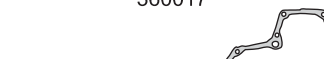

360017

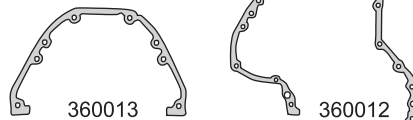

360013

360012

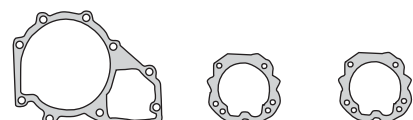

360014

360027

360027/1



360327

360029

360030

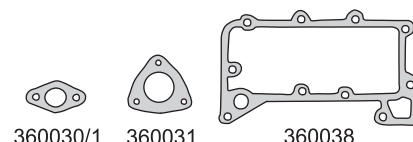

360030/1

360031

360038

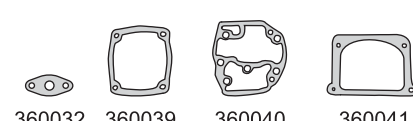

360032

360039

360040

360041



360042

360043

350443

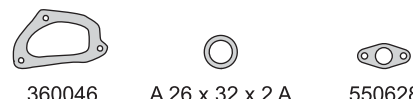

360046

A 26 x 32 x 2 A

550628



R360011V

R360012V

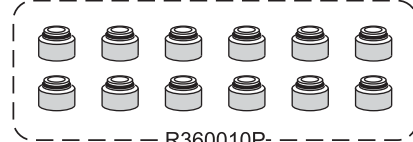

R360010P

M. BENZ

MERCEDES BENZ

taranto

Motor/Engine **Cm³** **HP** **Ø**
OM 355-6 **11580** **230** **128**
Mercedes Benz: 0371 - Bus 1926 1985/...

DIESEL

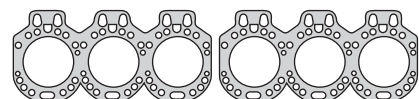

Nº OE	Descripción/Description	Mat.	Ref.
3555860390	Jgo. de juntas para motor		360400-R
3550160220	Junta tapa cilindros Ø 130 \pm 1.30	NFT	2 350607-3
	Jgo. tornillos tapa cilindros (HAS19038)		B350600
3460160221	Junta tapa válvulas	NFT	6 350610
3265800196	Jgo. junta para cárter (6)	NB	1 360411
3460150120	Tapa distribución	CG	1 350612
3562010180	Tapa bomba de agua	NB	1 350614
3451427060	Múltiple escape	AC	6 350615
0664920080	Múltiple admisión	NFT	2 350617
0664920080	Salida de escape	NFT	1 350718
3552030080	Termostato	NB	1 350619
3551840480	Bomba aceite	NB	1 350627
3552010080	Bomba de agua	NB	2 350629
3269970149	Cañería de agua	NB	6 350630
3520780080	Arandela retorno inyector A 8 x 12 x 1.5 C	CU	15 350032
3270750180	Tacómetro	NB	1 350633
3460180080	Conducto aceite	NB	1 350634
3600770180	Bomba inyectora	NB	2 350635
3550150020	Junta tapa lateral válvulas	NB	2 350636
3150150121	Tapa lateral cámara agua	NB	1 360437
3030180079	Medidor aceite	NB	1 350638
	Base a block compresor aire	NB	1 350639
	Tapa válvulas compresor aire	NB	1 350640
3520180180	Anular	CG	1 540041
	Entre cuerpo compresor aire	NB	1 350641
3551880080	Bomba aceite	NB	1 350642
071511040015	Entrada aire	NB	1 350643
0651810079	Bomba aceite	NB	1 350644
	Jgo. juntas compresor WAABCO (3)	VS	1 350645
	Kit de arandelas (100)	VS	1 360447
	Jgo. empaquetadura cigüeñal (2)	SNA	1 350458
	Jgo. juntas compresor (5)	VS	1 590260
071511026008	Tubo ventilación	NB	1 350662
	Junta de turbina turbo compresor	AC	1 810162
	Junta base turbo compresor	AC	1 810163
	Junta retorno turbo	NB	1 810364
	Junta entrada aceite turbo	NB	1 810365
	Junta salida aceite turbo	NB	1 810366
446.9970445	O'ring camisa inyector G 30.8 x 3.7	GS	6
	Arandela A 12 x 16 x 1 F	F	6
	Arandela A 14 x 18 x 1.5 A	AL	13
	Arandela A 14 x 20 x 1.5 C	CU	2
	Arandela A 16 x 21 x 1.5 C	CU	1
	Arandela A 18 x 22 x 1.5 A	AL	1
	Arandela A 18 x 22 x 1.5 C	CU	2
	Arandela A 20 x 24 x 1.5 C	CU	1
	Arandela A 20 x 26 x 1.5 C	CU	2
	Arandela A 22 x 27 x 1.5 C	CU	7
	Arandela A 24 x 30 x 1.5 A	AL	2
	Arandela A 26 x 34 x 2 A	AL	1
	Arandela A 30 x 36 x 2 A	AL	2
	Arandela A 30 x 36 x 2 C	CU	1
	Arandela A 35 x 41 x 2 C	CU	7



350607-3

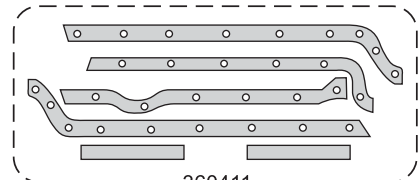

350610



360411

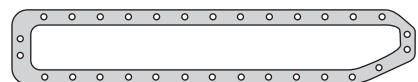

360437

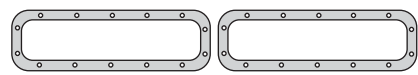

350636



350615

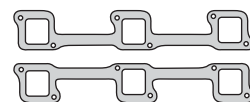

350617

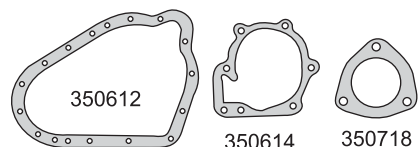

350612

350614

350718

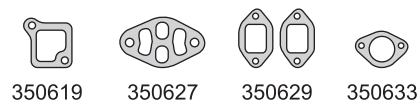

350619

350627

350629

350633



350630



350032

350634



350638

350635

350642



540041

350643

350662

350644

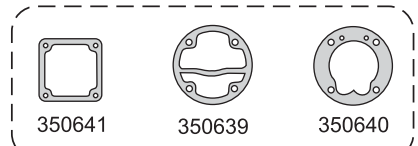

350641

350639

350640

350645

**MERCEDES
BENZ**



Motor/Engine	Cm³	HP	Ø
OM457 Electrónico 24V 252 - 456PS	11967	355/380	128
DIESEL			

Mercedes Benz: OM457LA/LAIII/HLA/HLA III
OM457.933/938/940/944/949
OM458.960/970/980/938CAM
O400BUS - Camión LS1938 - LK/LS
L2638 - Axor 2035/40/44
2540/44 -2640/44
3340/44 4140/44

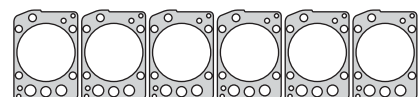

360808



360810

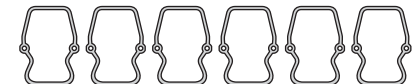

360810-1

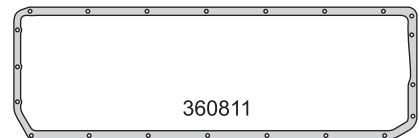

360811

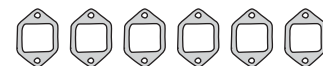

360015



360817

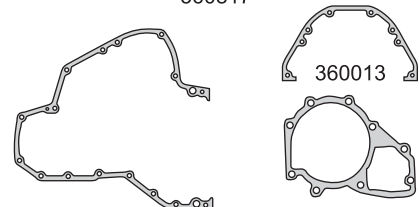

360013

360012

360014



360819

360029

360838

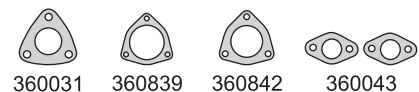

360031

360839

360842

360043



360845

360046

360846

360847

360848

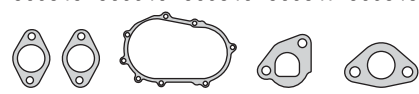

360849

360863

360864

360865

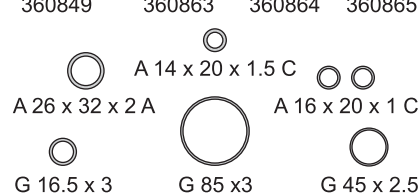

A 14 x 20 x 1.5 C

A 26 x 32 x 2 A

A 16 x 20 x 1 C

G 16.5 x 3

G 85 x3

G 45 x 2.5

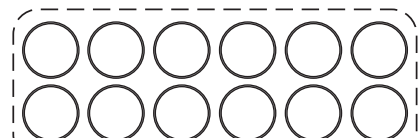

360870



R360811V

R360812V

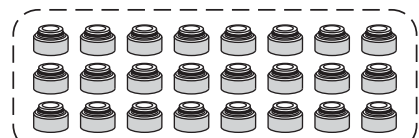

R360810V

Nº OE	Descripción/Description	Mat.	Ref.
	Jgo. de juntas para motor		360800-R
4570161120	Junta tapa cilindros Ø143 ± 0.45	MLS 6	360808
442900040/30/201	Jgo. tornillos para tapa de cilindros		B360800
4570160021	Junta tapa válvulas	NH 6	360810
	Junta tapa válvulas	GS 6	360810-1
440140022	Junta para cárter enteriza	NB 1	360811
4470150080	Tapa distribución	NB 1	360012
4570110080	Junta porta retén bancada	NB 1	360013
4572010080	Tapa bomba de agua	NB 1	360014
4031420380	Múltiple escape	AC 6	360015
4571410080	Múltiple admisión	NFT 6	360817
0249972848	O´ring termostato G 67 x 59 x 4	GS 2	360819
4422010481	Acople bomba de agua	NB 1	360029
4420180080	Tubo llenado aceite cárter	NB 1	360031
4421880580	Junta tapa refrigerador aceite	NB 1	360838
4572010180	Acople lateral block	AC	360839
4602010080	Empalme calefactor A	NB 1	360842
917003026003	Acople radiador aceite	NB 2	360043
9060170200	Arandela pico inyector	CU	360844
4570980080	Acople admisión	NB 1	360845
4570150080	Acople cierre distribución	CG 1	360046
4570150080	Acople cierre distribución	CG 1	360846
4421870080	Descarga aceite turbo	NB 1	360847
4421870180	Entrada aceite turbo	NB 1	360848
917003036003	Chupador de aceite	NB 2	360849
	Junta bomba combustible 025/030	NB	360863
	Asiento block bomba de aceite	NB 1	360864
	Válvula presión de aceite	NB 1	360865
4570110259	Jgo. suplemento camisa cilindros G146 x 155 (0.15)	AC	360870-0.15
4570110459	Jgo. suplemento camisa cilindros G146 x 155 (0.30)	AC	360870-0.30
4570110559	Jgo. suplemento camisa cilindros G146 x 155 (0.50)	AC	360870-0.50
1579970545	Jgo. o´ring camisa cilindros G146 x 155 (12)	GS 1	360870
	Junta tapa cilindros competición	AC	360890
	O´ring G 85 x 3	GS 1	
	O´ring G 45 x 2.5	GS 1	
	O´ring G 16.5 x 3	GS 1	
	Arandela A 26 x 32 x 2 A	AL 1	
	Arandela A 22 x 27 x 1.5 C	CU 1	
	Arandela A 16 x 20 x 1C	CU 2	
	Arandela A 14 x 20 x 1.5 C	CU 1	
	Kit de retenes completo		R360800
A0000533558	Jgo. retén válvulas (24)	V 1	R360810V
0219975347	Retén bancada 113 x 140 x 12	V 1	R360811V
0259973947	Retén bancada delant. 110 x 130 x 11	V 1	R360812V

M. BENZ



taranto

INSTRUCCIONES DE MONTAJE



1
Seleccionar el eje piloto para encajar el diámetro interno del retén guía de válvula e insertar.



2
Seleccionar el mandril con el diámetro interno más pequeño que encaja en el retén y montarlo a mano.



3
Deslizar el mandril en el eje piloto e insertar el mismo en la guía de válvulas.
Deslizar hacia abajo y luego retirar la herramienta.



HCRV - Herramienta de Instalación RGV Taranto.

Este dispositivo permite alinear correctamente el retén a la guía de válvula, eliminando así el riesgo de dañar el mismo durante el montaje.

- ▶ Permite instalar el retén de guía de válvulas evitando su caída hacia el interior del cilindro, permitiendo así el recambio del retén sin desmontar la tapa de cilindros.
- ▶ Es aplicable en vehículos nacionales e importados.



MWM



Motor/Engine	Cm³	HP	Ø
D229-4	3922	96	102

Ford: F100 1993/95 - F1000 1994/96
F4000 1992/93 - F2000 1980/...
FB4000 1985/...

Fiat: Excavadora FB80



DIESEL

Nº OE	Descripción/Description	Mat.	Ref.
922900013005/87	Jgo. de juntas para motor		310400-R
	Jgo. de juntas superior		310495
622708541044	Jta. tapa cilindros Ø 110 \pm 1.45	NFT 4 4	310407
	Jgo. tornillos tapa cilindros (HAS17038)		B310400
920808530014	Junta tapa válvulas	N 4 4	310410
630508530164	Jgo. junta para cárter (4)	NB 1 1	310411
632508530184	Tapa distribución	NB 1 1	310412
632508530154	Distribución bomba aceite	NB 1 1	310413
922208530134	Tapa bomba de agua	NB 2 2	310414
632138530094	Múltiple escape y admisión	NFT 8 8	310416
	Salida de escape G 58 x 71 x 11	NFT 1 1	310418
620808530014	Placa bomba de agua	NB 1 1	310419
62290853052	Bomba alimentación	NB 1 1	220128
	Base bomba nafta	NB 1 1	550628
	Junta	NB 1 1	310430
	Junta	NB 1 1	310435
	Junta	NB 1 1	310434
922408530575	Base bomba inyección	NB 1 1	400435
930508530214	Base filtro aceite	NB 1 1	310437
632508530054	Tapa trasera bancada	NB 1 1	310438
604931060443	O'ring G 35 x 4	GS 4 4	310439
604931000202	O'ring G 20 x 2	GS 1 1	310440
604931000324	O'ring G 6 x 2	GS 1 1	310441
90411025515	Acople escape	NB 1 1	310541
632148530124	Bombin bomba inyectora	NB 1 1	310442
620508530124	Base bomba inyectora lineal	NB 1 1	310443
604931060204	O'ring G 42.2 x 3	GS 2 2	310444
922508510014	Curva escape	NFT 1 1	310445
630508530154	Acople con escape	NFT 1 1	310446
630508530164	Complemento cárter	NB 2 2	310447
632488510144	Fijación filtro aire	NB 1 1	310448
922508510044	Tapa inspección	NB 1 1	310449
	Caja velocidades F100/1000/clark 5V	VS 1 1	310450
604931040062	O'ring G 20 x 4	GS 1 1	310451
604931000344	O'ring G 45 x 3	GS 1 1	310452
	Palier F4000	CB 1 1	310456
	Diferencial DANA 46 F100-45/97- 96/98	NH 1 1	310459
	Tubo ventilación	AC 1 1	350462
	Colector a escape a turbo	NB 1 1	350662
	Junta caract. turabo MWM D229	AC 1 1	310463
6049313041124	Suplemento camisa cilindros G110 x 4	V 8 8	310470
904920101014	Arandela A 8 x 11 x 1 A	AL 4 4	
904920100814	Arandela A 8 x 12 x 1 A	AL 16 16	
904921101014	Arandela A 10 x 14 x 1.5 A	AL 3 3	
904920101418	Arandela A 14 x 18 x 1.5 A	AL 1 1	
604921100811	Arandela A 8 x 14 x 1 A	AL 4 4	
904921101018	Arandela A 10 x 16 x 1 A	AL 1 1	
	Arandela A 20 x 26 x 1 C	CU 4 4	
604920600211	Arandela tapón cárter A 22 x 27 x 1 A	AL 1 1	
606901281017	Arandela A 10 x 20 x 2 C	CU 1 1	
	Arandela A 40 x 60 x 1.5	NB 2 2	
	Arandela A 12 x 18 x 1.5 A	AL 1 1	
	Arandela A 14 x 20 x 1.5 A	AL 2 2	

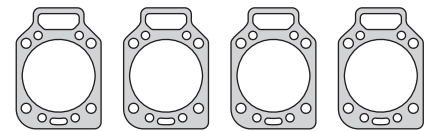

310407

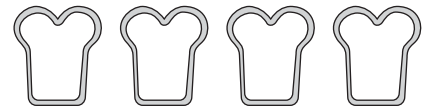

310410

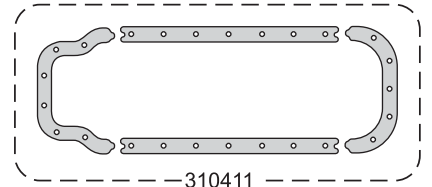

310411

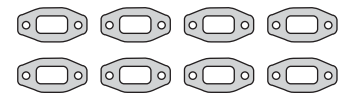

310416

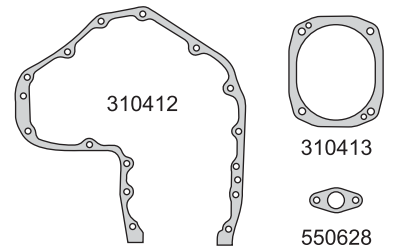

310412

310413

550628

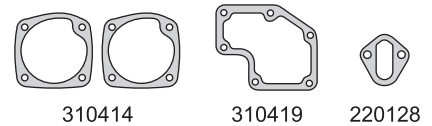

310414

310419

220128

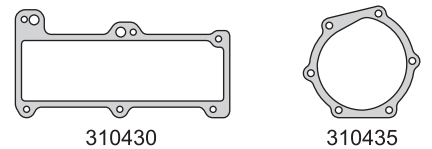

310430

310435

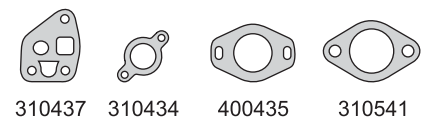

310437

310434

400435

310541

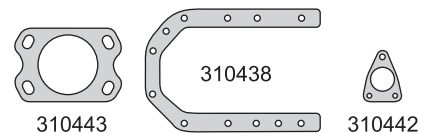

310443

310438

310442

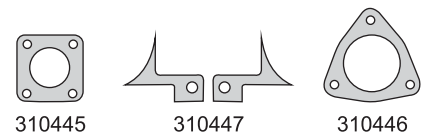

310445

310447

310446

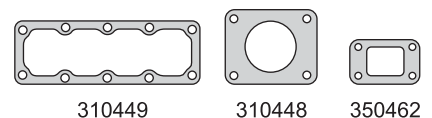

310449

310448

350462

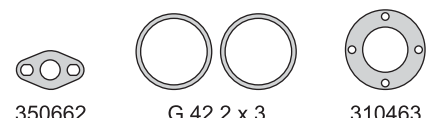

350662

G 42.2 x 3

310463

MWM

MWM



Motor/Engine	Cm³	HP	Ø
D229-4	3922	96	102

Ford: F100 1993/95 - F1000 1994/96
F4000 1992/93 - F2000 1980/...
FB4000 1985/...

Fiat: Excavadora FB80



DIESEL

Nº OE	Descripción/Description	Mat.		Ref.
	Arandela A 16 x 20 x 1.5 C	CU	4	
	O'ring G 30.8 x 3.7	GS	1	
	O'ring G 46 x 3	GS		
	Kit de retenes completo			R310400
	Jgo. retén válvulas (8)	V	1	R310410V
	Retén bancada 110 x 130 x 13	P	1	R310411P
	Retén distribución 78 x 100 x 13	V	1	R310412V

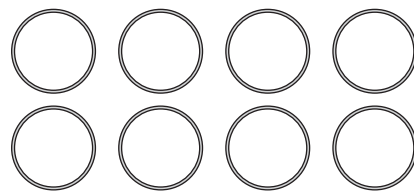

310470

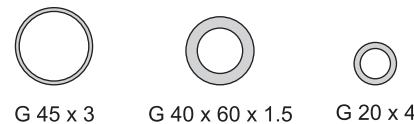

G 45 x 3 G 40 x 60 x 1.5 G 20 x 4



A 14 x 18 x 1.5 A



A 8 x 11 x 1 A



A 16 x 20 x 1.5 C G 20 x 2



G 30.8 x 3.7



A 8 x 14 x 1 A A 10 x 14 x 1.5 A



A 10 x 20 x 2 C



A 10 x 16 x 1 A A 8 x 12 x 1 A



A 16 x 20 x 1.5 C



A 14 x 20 x 1.5 A A 20 x 26 x 1 C



G 6 x 2



A 12 x 18 x 1.5 A A 22 x 27 x 1 A



R310412V R310411P

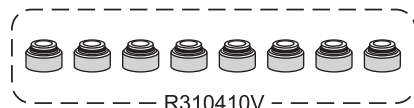

R310410V

MWM

MWM



Motor/Engine	Cm³	HP	Ø
D229-6	5883	145	102
D229-6 Turbo	5883	160	102

Ford: F14000 - F4000 1994/96
Cargo - F12000 - F14000 1985/...

Fiat: Tractor S90 - FE105 - FA120
FE105B



DIESEL

Nº OE	Descripción/Description	Mat.	Ref.
922900130177	Jgo. de juntas para motor		310500-R
	Jgo. de juntas superior		310595
622708541044	Jta. tapa cilindros Ø 110 ≤ 1.45 N.R. (HAS17038)	NFT 6 6	310407
	Jgo. tornillos tapa cilindros		B310500
920808530014	Junta tapa válvulas	N 6 6	310410
	Junta tapa válvulas C/G - 6.40 mm.	CG	310510
	Junta tapa válvulas C/G - 3.20 mm.	CG	310531
	Junta tapa válvulas AH 651 - 2.70 mm.	NB	310532
922508530137	Jgo. junta para cárter (4)	NB	1 310511
632508530184	Tapa distribución	NB	1 310412
632508530154	Distribución bomba aceite	NB	1 310413
922208530134	Tapa bomba de agua	NB	2 310414
632138530094	Múltiple admisión y escape	NFT 12 12	310416
	Salida de escape	NB 1 1	400218
620608530014	Bomba de agua a block	NB	1 310419
62290853052	Bomba combustible	NB	1 220128
	Base bomba nafta	NB	1 550628
	Junta	NB	1 310430
	Junta	NB	1 310434
	Junta	NB	1 310435
922408530575	Base boma inyectora rotativa	NB	1 400435
930508530214	Base filtro aceite	NB	1 310437
632508530054	Tapa trasera bancada	NB	1 310438
	Complemento cárter	NB	2 310539
	Complemento cárter	NB	2 310540
90411025515	Acople caño escape	NB 1 1	310541
632148530124	Bomba alimentadora	NB	1 310442
922908530094	Tubo llenado aceite	NFT	1 310542
620508530124	Bomba inyectora linea	NB	1 310443
922508510014	Curva escape	NFT 1 1	310445
630508530154	Acople sin escape	NFT 1 1	310446
632488510144	Fijación filtro aire	NB	1 310448
	Jgo. juntas con caja 5 velocidades 1992/...	VS	310550
	Palier 1992/...	NB	310556
604931000344	O'ring G 30.8 x 3.7	GS	1 310439
604931000202	O'ring G 45 x 3	GS	1 310440
	Complemento cárter	NB	310540
604931040062	O'ring G 6 x 2	GS	1 310441
604931000324	O'ring G 20 x 2	GS 4 6	310444
604931060443	O'ring G 20 x 4	NB	1 310451
904920101418	O'ring G 42.2 x 3	GS	2 310452
	Escape a turbo	AC	1 310462
	Turbo ventilación	NB	1 350662
	Junta caract. turbo S-2 A	AC	1 310563
604931041104	Suplemento camisa cilindros G110 x 4	V	12 310470
904920101014	Arandela A 10 x 14 x 1 A	AL	6
	Arandela A 8 x 12 x 1 A	AL	6
904921101016	Arandela A 14 x 18 x 1.5 A	AL	16
904921101014	Arandela A 10 x 16 x 1 A	AL	6
	Arandela A 40 x 60 x 1.5	NB	1
	Arandela A 10 x 14 x 1.5 A	AL	6
	Arandela A 10 x 14 x 1 C	CU	1
	Arandela A 10 x 20 x 2 C	CU	6

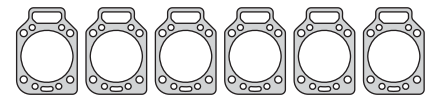

310407



310410

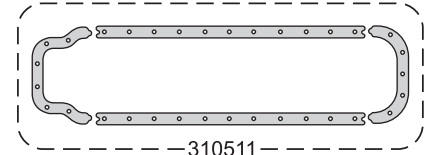

310511

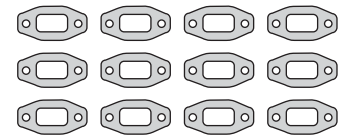

310416

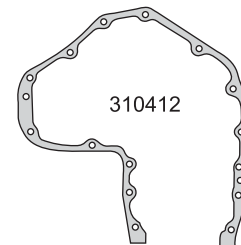

310412

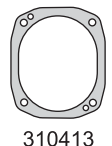

310413

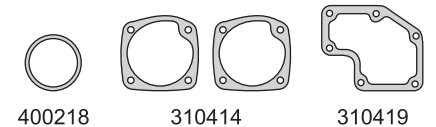

400218

310414

310419

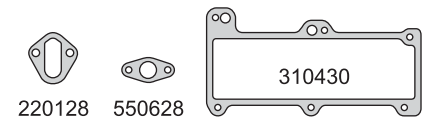

220128

550628

310430

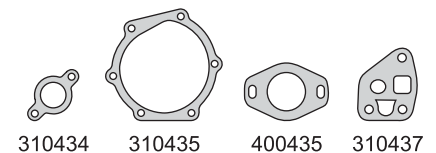

310434

310435

400435

310437

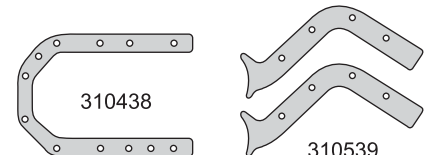

310438

310539

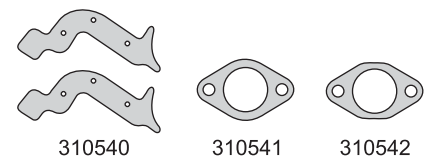

310540

310541

310542

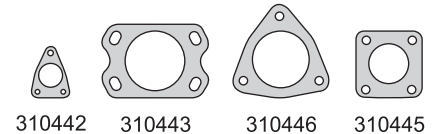

310442

310443

310446

310445

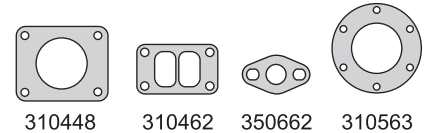

310448

310462

350662

310563

MWM

MWM



Motor/Engine	Cm³	HP	Ø
D229-6	5883	145	102
D229-6 Turbo	5883	160	102

Ford: F14000 - F4000 1994/96
Cargo - F12000 - F14000 1985/...

Fiat: Tractor S90 - FE105 - FA120
FE105B



DIESEL

Nº OE	Descripción/Description	Mat.		Ref.
604920600211	Arandela A 12 x 15 x 1.5 C	CU	2	
	Arandela A 14 x 20 x 1.5 A	AL	4	
	Arandela A 16 x 20 x 1.5 C	CU	6	
	Kit de retenes completo			R310500
	Jgo. retén válvulas (12)	P	1	R310510P
	Retén bancada 110 x 130 x 13	P	1	R310411P
	Retén distribución 78 x 100 x 13	V	1	R310412V

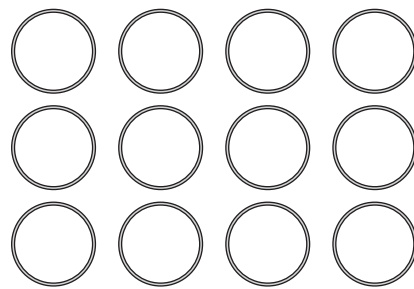

310470



G 20 x 2



G 45 x 3

G 42.2 x 3

G 20 x 4

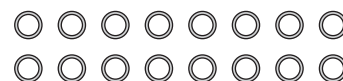

A 14 x 18 x 1.5A



A 10 x 14 x 1 A

A 12 x 15 x 1.5 C



A 10 x 20 x 2 C



A 10 x 16 x 1 A

A 8 x 12 x 1 A



A 16 x 20 x 1.5 C



A 10 x 14 x 1.5 A

A 10 x 14 x 1 C



A 40 x 60 x 1.5

G 6 x 2

G 30.8 x 3.7



A 14 x 20 x 1.5 A



R310412V

R310411P

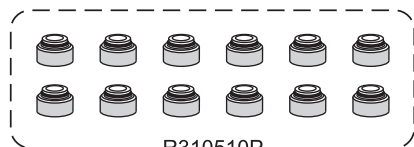

R310510P

MWM

MWM



Motor/Engine	Cm³	HP	Ø
D226-4	4156	82	105

Ford: Camión F4000 1986/...
M. Ferguson: Tractor 85 1986/...
Valmet: Tractor 86-ID



DIESEL

Nº OE	Descripción/Description	Mat.	Ref.
	Jgo. de juntas para motor		● 320400-R
	Jgo. de juntas para motor		● 320400
922608548014	Junta tapa cilindros Ø 107 \pm 1.20	N.R.	NFT 4 320407
92250853.8054	Junta tapa válvulas		CG 4 310531
922508530114	Junta para cárter		NB 1 320411
632508530184	Tapa distribución		NB 1 310412
632508530154	Distribución bomba vacío		NB 1 320813
922208530134	Tapa bomba de agua		NB 1 310414
632138530094	Múltiple admisión y escape		NFT 8 310416
	Salida de escape		1 320418
922508510014	Placa bomba de agua		NB 1 310419
922208330024	Base filtro aceite		NB 1 310437
632508530054	Tapa trasera bancada		NB 1 310438
632148530124	Bombín inyectora		NB 1 310442
620508530124	Bomba inyectora lineal		NB 1 310443
922608530124	Junta		NFT 1 320444
922508510014	Salida de escape		NFT 1 310445
922608530134	Junta		NB 2 320445
	Refuerzo cárter		NB 2 310447
922608530104	Filtro de aire		NB 1 320448
	O'ring G 40 x 3		GS 2
	O'ring G 30.8 x 3.7		GS 3
	O'ring G 20 x 4		GS 1
	O'ring G 6 x 2		GS 1
	Arandelas A 10 x 14 x 1 A		AL 4
	Arandelas A 22 x 27 x 1.5 A		AL 1
	Arandelas A 11 x 16 x 1.5 A		AL 12
	Arandelas A 8 x 12 x 1 C		CU 8
	Arandelas pico inyector A 10 x 20 x 2 C		CU 4
	Arandelas A 14 x 18 x 1.5 A		AL 8
	Anillo G 22 x 33 x 8		GS 4
	O'ring G 45 x 3		GS 1
	Kit de retenes completo		R310400
	Jgo. retén válvulas (8)		P R310410P
	Retén bancada 110 x 130 x 13		P 1 R310411P
	Retén distribución 78 x 100 x 13		V 1 R310412V

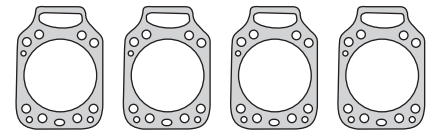

320407

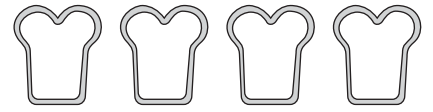

310531

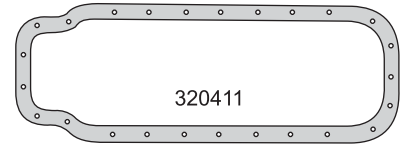

320411

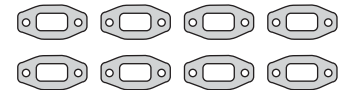

310416

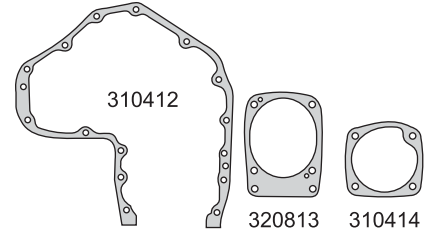

310412

320813

310414

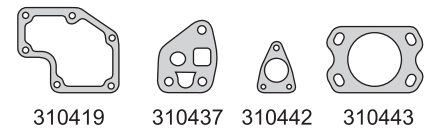

310419

310437

310442

310443

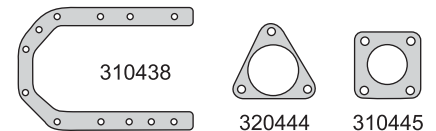

310438

320444

310445



320445

310447

320448



G 40 x 3

G 45 x 3

G 20 x 4



G 30.8 x 3.7

G 22 x 23 x 8

G 6 x 2



A 14 x 18 x 1.5 A

A 8 x 12 x 1 C



A 10 x 14 x 1 A

A 10 x 20 x 2 C

A 22 x 27 x 1.5 A

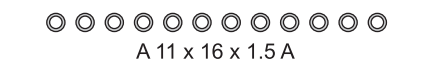

A 11 x 16 x 1.5 A

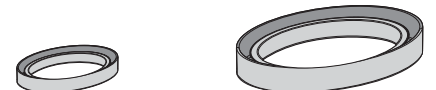

R310412V

R310411P

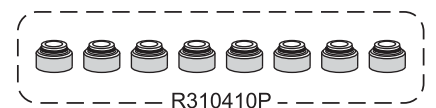

R310410P

MWM



Motor/Engine **Cm³** **HP** **Ø**

D225-3 **2550** **50** **95**

Valmet: Tractor 65ID - 62ID 1970/76

DIESEL



Nº OE	Descripción/Description	Mat.	Ref.
	Jgo. de juntas para motor	●	320800-R
	Jgo. de juntas para motor		320800
622708540024	Junta tapa cilindros Ø 110 \pm 1.20	NFT 3	320807
922508538054	Junta tapa válvulas		320810
	Junta para cárter	NB 1	320811
63250830184	Tapa distribución	NB 1	310412
	Distribución bomba vacío	NB 1	320813
922208530134	Bomba de agua	NB 2	310414
632138530094	Múltiple escape (6)	NFT 6	310416
	Salida de escape	NFT 1	320818
922208530134	Placa bomba de agua	NB 1	310419
	Junta tapa válvulas	CG 3	310531
922208530024	Base filtro aceite	NB 1	310437
632508530054	Tapa trasera bancada	NB 1	310438
604931000202	O'ring G 20 x 2	GS	310440
604931000324	O'ring G 6 x 2	GS 1	310441
	Acople escape	NB 1	310541
632148530124	Bomba inyectora	NB 1	310442
	Brida	NFT	320842
620508530124	Bomba inyectora	NB 1	310443
604931060204	O'ring G 40 x 3	GS 2	310444
922508510014	Curva escape	NFT 1	310445
	Curva escape	NFT	320845
630508530154	Acople caño escape	NFT 1	310446
	O'ring G 45 x 3	GS 1	320846
632488510144	Fijación filtro aire	NB 1	310448
	Arandela A 10 x 20 x 2 C	CU 3	320848
	Arandela A 22 x 27 x 1 C	CU 1	320849
604931040062	O'ring G 20 x 4	GS 1	310451
	Junta suplemento camisa cilindros G110 x 4	V 6	310470
	Jgo. suplemento camisa cilindros G 110 x 4 (6)	GS	320870
604921100811	Arandela A 8 x 14 x 1 C	CU 6	
904921101014	Arandela A 10 x 14 x 1 C	CU 4	
904921101018	Arandela A 10 x 16 x 1 A	AL 3	
	O'ring G 30.8 x 3.7	GS 3	
	Arandela A 14 x 18 x 1.5 A	AL 16	
	Kit de retenes completo		R310800
	Jgo. retén válvulas (6)	P	R310810P
	Retén bancada 110 x 130 x 13	P 1	R310411P
	Retén distribución 78 x 100 x 13	V 1	R310412V

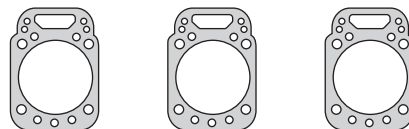

320807



310531

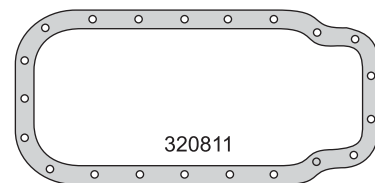

320811

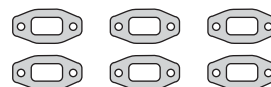

310416

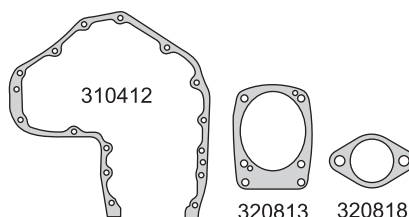

310412

320813

320818

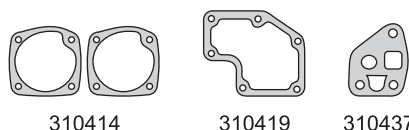

310414

310419

310437

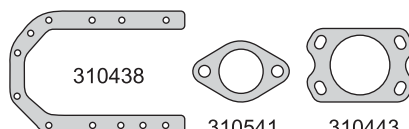

310438

310541

310443

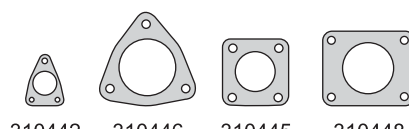

310442

310446

310445

310448



G 40 x 3

G 20 x 4

G 6 x 2

G 45 x 3



A 10 x 14 x 1 C



A 8 x 14 x 1 C



A 22 x 27 x 1 C



A 10 x 16 x 1 A



A 10 x 20 x 2 C



310470



R310412V



R310411P

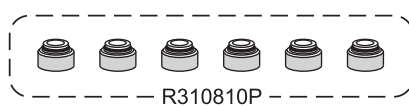

R310810P

MWM

MWM



Motor/Engine	Cm³	HP	Ø
4.10 X10	4300	90	103
4.10T	4300	133	103
4.10TCA	4300	167	103

Agrale: 7000/7500/8500
Ford: Euro I/II/III
Volkswagen: 7100/8120/8140/8150/13150



DIESEL

Nº OE	Descripción/Description	Mat.	Ref.
	Jgo. de juntas para motor		330400-R
961008540144	Junta tapa cilindros Ø 113.4 ± 1.45	NFT 4	330407
961008530014	Junta tapa válvulas	N 4	330410
941008530064	Junta para cárter	NB 1	330411
941008530044	Tapa distribución	NB 1	330412
941008530054	Placa distribución	NB 1	330413
961008530204	Múltiple escape	GFT 4	330415
961008530144	Múltiple admisión	NFT 4	330417
941008530024	Salida de escape	NFT 1	330418
961008530174	Entrada agua	NB 1	330419
922908530584	Base bomba alimentación	NB 1	220128
961008530094	Termostato	NB 1	330430
623208520064	Retorno aceite	NB 1	330431
961008530074	Cabeza intercambiador	NB 1	330432
623208520044	Lubricación a turbo	NB 1	330433
961008530044	Cuerpo respiradero motor	NB 1	330434
961008530084	Radiador aceite	NB 2	330435
922908530604	Base bomba inyectora	NB 1	330436
	O'ring G 14 x 3	GS 4	
	O'ring G 24.99 x 3.53	GS 4	
	O'ring G 28.2 x 5	GS 2	
	O'ring G 34 x 3	GS 1	
	O'ring G 40.64 x 5.33	GS 2	
	O'ring G 50.52 x 1.78	GS 2	
	O'ring G 79 x 1.8	GS 1	
	O'ring G 88.27 x 5.33	GS 1	
	O'ring G 126.67 x 2.62	GS 1	
	Arandela A 8 x 14 x 1 A	AL 8	
	Arandela A 7 x 15 x 2 C	CU 4	
	Arandela A 10 x 16 x 1 A	AL 1	
	Arandela A 12 x 18 x 1.5 C	CU 4	
	Arandela A 14 x 18 x 1.5 A	AL 14	
	Arandela A 18 x 24 x 1.5 C	CU 2	
	Arandela A 22 x 26 x 1.5 C	CU 1	
	Arandela A 21 x 30 x 2 A	AL 1	
	Anillo G 74 x 85 x 10	GS	
	Anillo G 43 x 51 x 6.5	GS	
	Suplemento camisa cilindros G 110 x 4	V 8	310470
	Kit retenes completo		R330400
	Jgo. retén válvulas (8)	V 1	R310410V
	Retén bancada 130 x 160 x 12	V 1	R330411V
	Retén distribución 78 x 100 x 13	V 1	R310412V

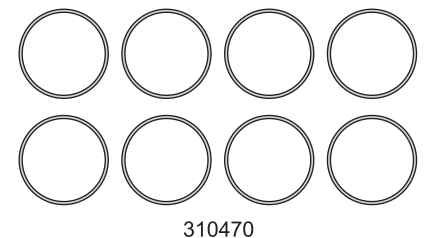
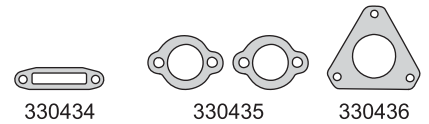
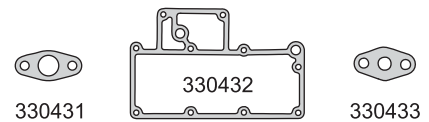
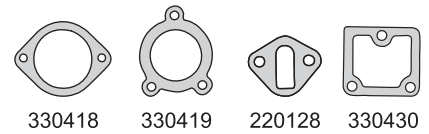
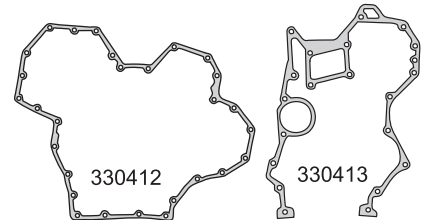
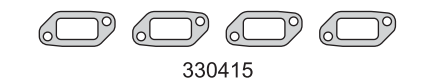
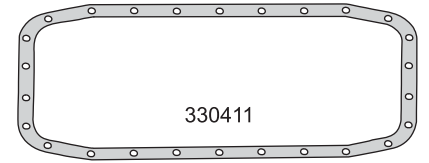
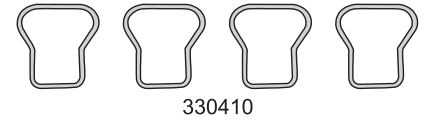
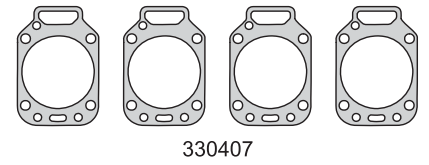

MWM

MWM



Motor/Engine	Cm³	HP	Ø
6.10 X10	6450	139	103
6.10T	6450	201	103
6.10TCA	6450	250	103

Ford: F14000 1995/98 - Euro I/II
 Volkswagen: 13180 - 15180 - 16210



DIESEL

Nº OE	Descripción/Description	Mat.	Ref.
	Jgo. de juntas para motor		330700-R
	Junta tapa cilindros Ø 113.4 ± 1.45	NFT 6	330407
	Junta tapa válvulas	N 6	330410
	Junta para cárter	NB 1	330711
	Tapa distribución	NB 1	330412
	Tapa distribución 6.10	NB 1	330712
	Placa distribución	NB 1	330413
	Placa distribución 6.10	NB 1	330713
	Múltiple escape	GFT 6	330415
	Múltiple admisión	NFT 6	330417
	Salida de escape	NFT 1	330718
	Entrada agua	NB 1	330419
	Curva múltiple admisión	NFT 1	330720
	Múltiple admisión	NFT 1	330721
	Anillo 115 x 77	NB 1	330723
	Base bomba alimentación	NB 1	220128
	Termostato	NB 1	330430
	Retorno aceite	NB 1	330431
	Cabeza intercambiador	NB 1	330432
	Lubricación a turbo	NB 1	330433
	Cuerpo respiradero motor	NB 1	330434
	Radiador aceite	NB 2	330435
	Base bomba inyectora	NB 1	330436
	Bomba aceite	NB 1	330737
	Suplemento camisa cilindros G 110 x 4	V 12	310470
	O'ring G 126.67 x 2.62	GS 1	
	O'ring G 88.27 x 5.33	GS 1	
	O'ring G 79 x 1.8	GS 1	
	O'ring G 75 x 3	GS 2	
	O'ring G 50.39 x 3.53	GS 2	
	O'ring G 46.99 x 5.33	GS 2	
	O'ring G 50.52 x 1.78	GS 2	
	O'ring G 42.2 x 3	GS 1	
	O'ring G 34 x 3	GS 1	
	O'ring G 28.2 x 5	GS 2	
	O'ring G 25.07 x 2.62	GS 1	
	O'ring G 24.99 x 3.53	GS 6	
	O'ring G 20 x 4	GS 1	
	O'ring G 14 x 3	GS 6	
	O'ring G 74 x 8.5 x 10	GS	
	O'ring G 12.5 x 1.5	GS 1	
	O'ring G 6 x 2	GS 2	
	Arandela A 21 x 30 x 2 A	AL 1	
	Arandela A 22 x 26 x 1.5 C	CU 1	
	Arandela A 14 x 19 x 1.5 C	CU 3	
	Arandela A 14 x 18 x 1.5 A	AL 18	
	Arandela A 12 x 18 x 1.5 C	CU 2	
	Arandela A 10 x 16 x 1 A	AL 4	
	Arandela A 7 x 15 x 1 F	FI 6	
	Arandela A 7 x 15 x 2 C	CU 6	
	Arandela A 10 x 14 x 1 F	FI 1	
	Arandela A 8 x 14 x 1 A	AL 6	
	Kit de retenes completo		R330700

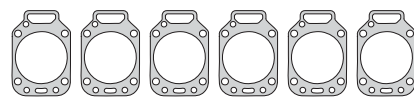

330407



330410

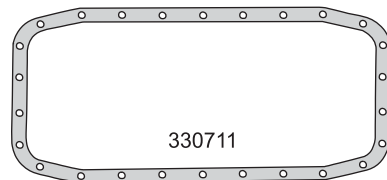

330711



330415



330417

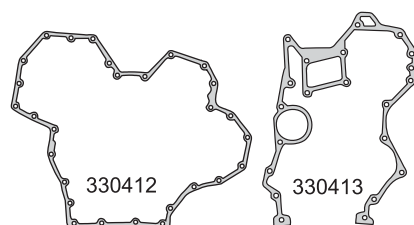

330412

330413

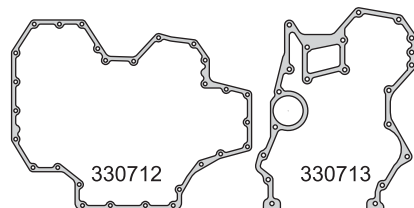

330712

330713

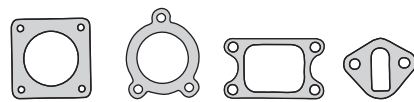

330718

330419

330720

220128

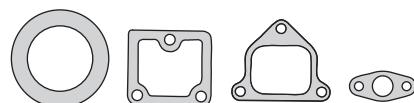

330723

330430

330721

330431

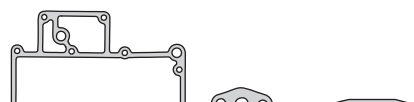

330432

330433

330434

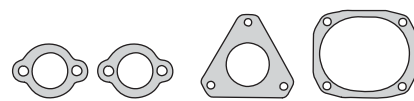

330435

330436

330737



G 75 x 3



G 24.99 x 3.53

MWM

MWM



Motor/Engine	Cm³	HP	Ø
D229-3	2942	72	102

Agrale: Camión TX 1600 1983/...
Dynapac: Cilindro Vibratorio CHF 44 1983/...
Valmet: Autoelevador - E300 - Tractor 68 1983/...



DIESEL

Nº OE	Descripción/Description	Mat.	Ref.
922900013005/87	Jgo. de juntas para motor		330800-R
	Junta tapa cilindros Ø 110 \pm 1.45	NFT 3	310407
622708541044	Jgo. tornillos tapa cilindros (HAS17038)		B330800
	Junta para cárter	NB 1	320811
	Tapa distribución	NB 1	310412
632508530184	Distribución bomba vacío	NB 1	320813
	Tapa bomba de agua	NB 2	310414
922208530134	Múltiple escape	NFT 6	310416
632138530094	Salida de escape	NFT 1	320818
	Placa bomba de agua	NB 1	310419
620808530014	Junta tapa válvulas	CG 3	310531
	Base filtro aceite	NB 1	310437
930508530214	Tapa trasera bancada	NB 1	310438
632508530054	O'ring G 20 x 2	GS 3	310440
604931000202	O'ring G 6 x 2	GS 1	310441
604931000324	Acople escape	NB 1	310541
90411025515	Bombin bomba inyectora	NB 1	310442
632148530124	Base bomba inyectora lineal	NB 1	310443
620508530124	O'ring G 42 x 3	GS 2	310444
604931060204	Curva escape	NFT 1	310445
922508510014	Acople con escape	NFT 1	310446
630508530154	Fijación filtro aire	NB 1	310448
632488510144	O'ring G 20 x 4	GS 1	310451
604931040062	Suplemento camisa cilindros G110 x 4	V 6	310470
	Arandela A 14 x 18 x 1.25 A	AL 16	
	Arandela A 8 x 14 x 1 A	AL 3	
604921100811	Arandela A 20 x 26 x 1 C	CU 1	
	Arandela tapón cárter A 22 x 27 x 1 A	AL 1	
604920600211	Arandela A 10 x 20 x 2 C	CU 3	
606901281017	Arandela A 10 x 20 x 1.5 A	AL 2	
	Arandela A 12 x 18 x 1.5 A	AL 2	
	Arandela A 10 x 14 x 1 A	AL 4	
	O'ring G 30.8 x 3.7	GS 1	
	O'ring G 44 x 3	GS 1	
	Kit de retenes completo		R330800
	Retén bancada 110 x 130 x 13	P 1	R310411P
	Retén distribución 78 x 100 x 13	V 1	R310412V

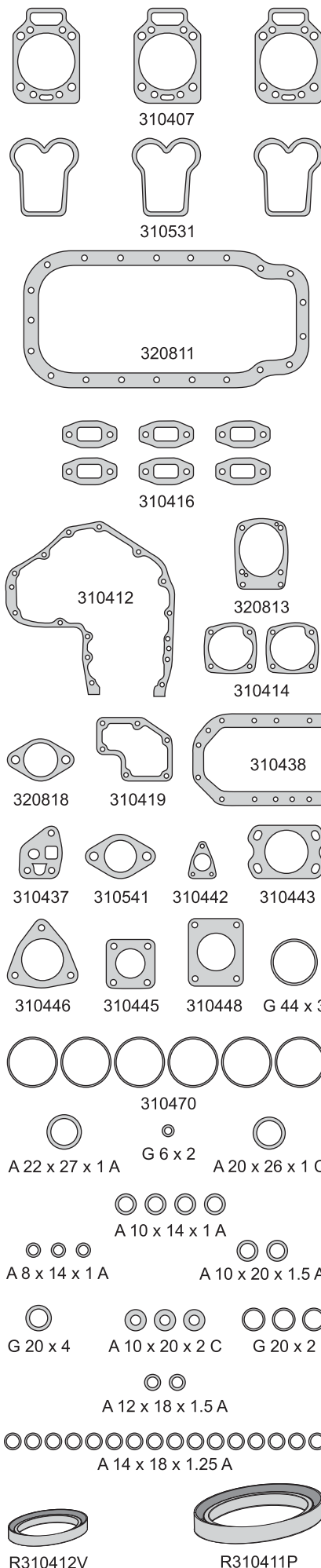

MWM

MWM



Motor/Engine	Cm³	HP	Ø
4.12 TCE Common Rail	4800	150/180	105

Agrale: 8500 - 9200
Volkswagen: Constellation 13.180E - 15.180E



DIESEL

Nº OE	Descripción/Description	Mat.	Ref.
	Jgo. de juntas para motor	●	331200-R MLS
961288540044	Junta tapa cilindros Ø 113.5 ± 1.30	NFT	2 331208
961008530034	Junta tapa válvulas	N	4 330410
941008530474	Junta para cárter	NB	1 330411
961208530014	Junta tapa distribución	NB	1 331212
961208530024	Junta placa distribución	NB	1 331213
961008530204	Múltiple escape	GFT	4 330415
941008530164	Múltiple admisión	NFT	4 330417
941088530354	Entrada de agua	NB	1 330419
941088530354	Termostato	NB	1 330430
941088530454 941208530034	Retorno aceite	NB	1 330431
941088530394	Cabeza intercambiador	NB	1 330432
941088530444	Lubricación a turbo	NB	1 330433
961007160024	Cuerpo respiradero motor	NB	1 330434
941088530334	Radiador aceite	NB	1 330435
941208530014	Junta	NFT	1 331245
961008530214	Colector a escape turbo	AC	1 350462
	Junta caract. turbo S-2 A	AC	1 310563
904931361131	Suplemento camisa cilindros G 110 x 4	V	8 310470
961083400384	O'ring camisa cilindros	CU	4 330470-0.10
	O'ring G 209.14 x 3.53	GS	1
	O'ring G 91.67 x 3.53 S	GS	1
	O'ring G 85.09 x 5.33	GS	1
	O'ring G 79 x 1.8	GS	1
	O'ring G 77.62 x 3.53	GS	1
	Anillo G 73 x 84 x 9	GS	2
	O'ring G 56.82 x 2.62	GS	1
	O'ring G 50.39 x 3.53	GS	1
	O'ring G 34 x 3	GS	1
	O'ring G 24.99 x 3.53	GS	4
	O'ring G 20 x 4	GS	1
	O'ring G 17.17 x 1.78	GS	5
	O'ring G 8 x 2.4	GS	1
	O'ring G 7.65 x 1.78	GS	4
	Arandela A 24 x 29 x 2 C	CU	1
	Arandela A 22 x 26 x 1.5 C	CU	2
	Arandela A 21 x 30 x 2 A	AL	1
	Arandela A 18 x 22 x 1.5 A	AL	1
	Arandela A 16 x 22 x 1.5 A	AL	1
	Arandela A 14 x 18 x 1.5 A	AL	11
	Arandela A 12 x 18 x 1.5 C	CU	2
	Arandela A 8 x 12 x 1 C	CU	2
	Arandela A 8 x 14 x 1 A	AL	6
	Arandela A 7 x 15 x 2 C	CU	4
	Kit de retenes completo		R330400
904960640089	Jgo. retén válvulas (8)	V	1 R310410V
904960651301	Retén bancada 130 x 160 x 12	V	1 R330411V
904960640784	Retén distribución 78 x 100 x 13	V	1 R310412V

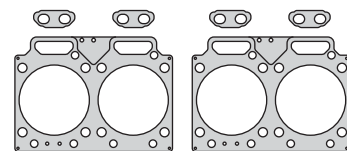

331208



330410

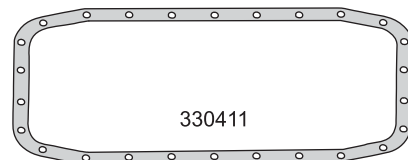

330411



330415



330417

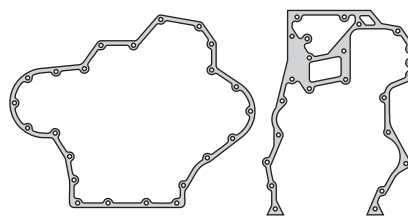

331212

331213

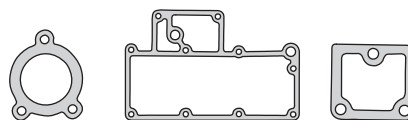

330419

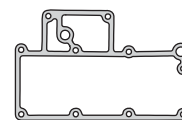

330432

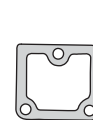

330430



330431



330433



330434



350462



331245



330435



310563

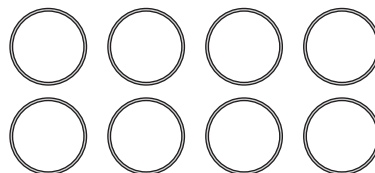

310470



330470-0.10



R330411V



R310412V



R310410V

MWM

MWM



Motor/Engine	Cm³	HP	Ø
6.12 TCE Common Rail	7118	210/260 310	105

Volkswagen: 26.260E, 31.260E, 17.260EOT, 17.210EOD

Volvo: VM210, 260, 310



DIESEL

Nº OE	Descripción/Description	Mat.	Ref.
	Jgo. de juntas para motor		331300-R MLS
961288540044	Junta tapa cilindros Ø 113.5 ± 1.30	NFT	3 331208
961008530034	Junta tapa válvulas	N	6 330410
961088530354 961008530434	Junta para cárter	NB	1 330711
961208530014	Junta tapa distribución	NB	1 331212
961208530024	Junta placa distribución	NB	1 331213
961008530204	Múltiple escape	GFT	6 330415
941008530164	Múltiple admisión	NFT	6 330417
941088530354	Entrada de agua	NB	1 330419
941088530354	Termostato	NB	1 330430
941088530454 941208530034	Retorno aceite	NB	1 330431
941088530394	Cabeza intercambiador	NB	1 330432
941088530444	Lubricación a turbo	NB	1 330433
961007160024	Cuerpo respiradero motor	NB	1 330434
941088530334	Radiador aceite	NB	1 330435
941208530014	Junta	NFT	1 331245
961008530214	Colector a escape turbo	AC	1 350462
	Junta caract. turbo S-2 A	AC	1 310563
904931361131	Suplemento camisa cilindros G 110 x 4	V	12 310470
961083400384	O'ring camisa cilindros	CU	6 330470-0.10
	O'ring G 209.14 x 3.53	GS	1
	O'ring G 91.67 x 3.53	S	1
	O'ring G 85.09 x 5.33	GS	1
	O'ring G 79 x 1.8	GS	1
	O'ring G 77,62 x 3.53	GS	1
	O'ring G 73 x 84 x 9	GS	1
	O'ring G 56.82 x 2.62	GS	1
	O'ring G 50.39 x 3.53	S	1
	O'ring G 34 x 3	S	1
	O'ring G 24.99 x 3.53	GS	6
	O'ring G 20 x 4	S	1
	Arandela A 24 x 29 x 2 C	CU	1
	Arandela A 22 x 26 x 1.5 C	CU	2
	Arandela A 21 x 30 x 2 A	AL	1
	Arandela A 20 x 26 x 1 A	AL	1
	Arandela A 18 x 22 x 1.5 A	AL	1
	Arandela A 16 x 22 x 1.5 A	AL	2
	Arandela A 14 x 18 x 1.5 A	AL	13
	Arandela A 12 x 18 x 1.5 A	AL	1
	Arandela A 12 x 18 x 1.5 C	CU	2
	Arandela A 8 x 12 x 1 C	CU	2
	Arandela A 8 x 14 x 1 A	AL	8
	Arandela A 7.5 x 15 x 2 C	CU	6
	Kit de retenes completo		R330700
904960640089	Jgo. retén válvulas (12)	V	1 R330710V
904960651301	Retén bancada 130 x 160 x 12	V	1 R330411V
904960640784	Retén distribución 78 x 100 x 13	V	1 R310412V

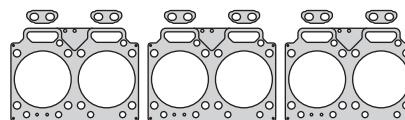

331208



330410

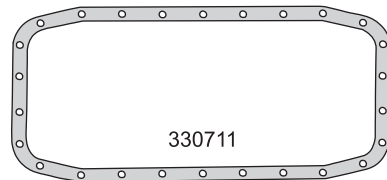

330711



330415



330417

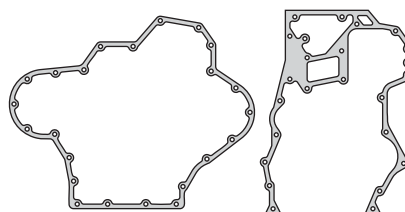

331212

331213

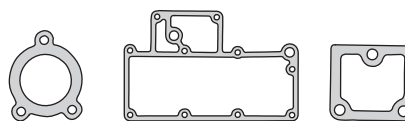

330419

330432

330430

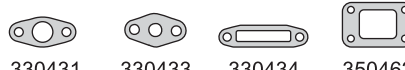

330431

330433

330434

350462

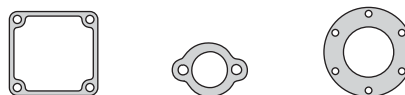

331245

330435

310563

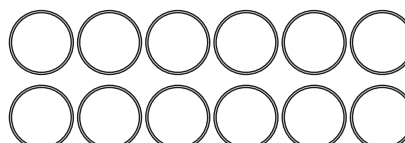

310470



330470-0.10

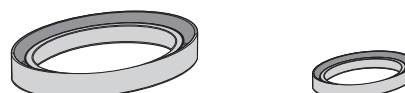

R330411V

R310412V

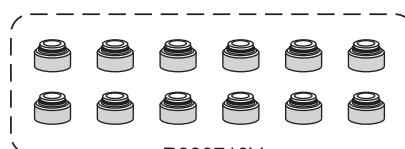

R330710V

MWM

MWM



Motor/Engine	Cm³	HP	Ø
D225-4	2977	68	95
D225-4	3400	68	95

Fiat: 850E
Valmet: Tractor 85ID 1970/76



DIESEL

Nº OE	Descripción/Description	Mat.	Ref.
922500130297	Jgo. de juntas para motor		440000
622708540024	Junta tapa cilindros Ø 110 \pm 1.20	NFT	4 320807
922508538054	Junta tapa válvulas	CG	4 310531
630508530144	Junta para cárter enterizo	NB	1 440011
632508530184	Tapa distribución	NB	1 310412
632508530154	Distribución bomba de aceite	NB	1 320813
922208570134	Tapa bomba de agua	NB	2 310414
632138570094	Multiple escape	NFT	8 310416
623208520034	Salida de escape	NFT	1 320818
922208530134	Placa bomba de agua	NB	1 310419
620808510014	Colector escape	NFT	2 440035
922508100014	Junta	NB	1 440036
922208330024	Baje filtro aceite	NB	1 310437
632508530054	Tapa trasera bancada	NB	1 310438
922508530014	Tapa carcasa intercambiable	NB	1 440040
90411025515	Llenado de aceite	NFT	1 310542
620508530124	Bomba inyectora	NB	1 310443
922508510014	Salida de escape	NFT	1 310445
630588530154	Acople caño escape	NFT	1 310446
632488510144	Fijación filtro de dire	NB	1 310448
922588510044	Tapa inspección	NB	1 310449
604931301124	Suplemento camisa cilindros G110 x 4	V	8 310470
	O'ring G 42.2 x 3	GS	2
	O'ring G 45 x 3	GS	1
	O'ring G 20 x 4	GS	1
	O'ring G 18.77 x 1.78	GS	4
	O'ring G 6 x 2	GS	1
	O'ring G 30.8 x 3.7	GS	1
906901281017	Arandela A 10 x 21 x 2 C	CU	4
904920101418	Arandela A 14 x 18 x 1.5 A	AL	16
	Arandela A 8 x 12 x 1 A	AL	4
904920102227	Arandela A 22 x 27 x 1.5 C	CU	1
	Arandela A 13 x 18 x 1.5 C	CU	2
	Arandela A 10 x 14 x 1 C	CU	1
90492010081	Arandela A 8 x 14 x 1 A	AL	3
	Arandela A 20 x 26 x 1 A	AL	1
	Kit de retenes completo		R310400
	Jgo. retén de válvulas (8)	V	R310410V
	Retén bancada 110 x 130 x 13	P	R310411P
	Retén distribución 78 x 100 x 13	V	R310412V

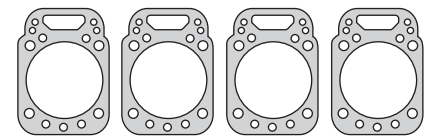

320807

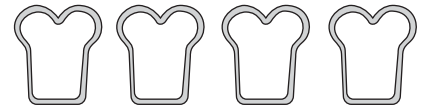

310531

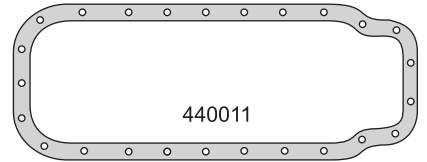

440011

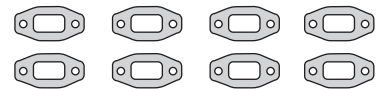

310416

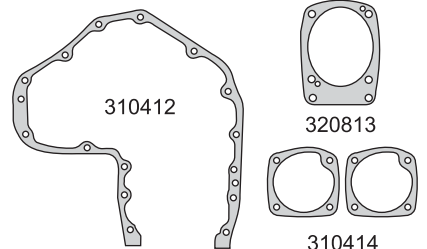

310412

320813

310414

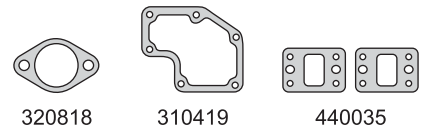

320818

310419

440035

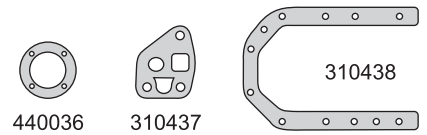

440036

310437

310438

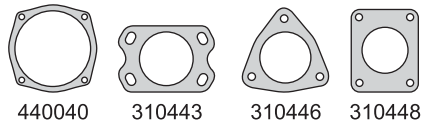

440040

310443

310446

310448

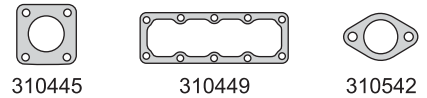

310445

310449

310542

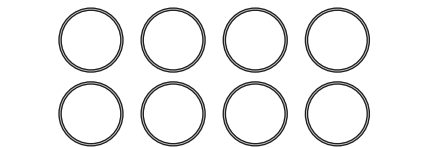

310470

G 45 x 3

G 42.2 x 3

G 30.8 x 3.7



A 14 x 18 x 1.5 A



R310411P



R310412V

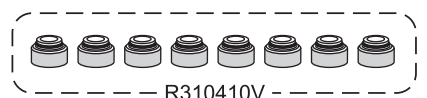

R310410V

MWM



Motor/Engine	Cm³	HP	Ø
D225-6	5100	102	95

Dodge: Camión 1978/...
Fiat: Tractor AD7B -980E - S90
Valmet: Tractor 110ID



DIESEL

Nº OE	Descripción/Description	Mat.	Ref.
922500130318	Jgo. de juntas para motor		440100-R
622708540014	Junta tapa cilindros Ø 110 \pm 1.20	NFT 6	320807
922508538054	Juntas tapa válvulas	CG 6	310531
630508530164	Jgo. junta para cárter (4)	NB 1	310511
632508530184	Tapa distribución	NB 1	310412
632508530154	Distribución bomba aceite	NB 1	320813
922208530134	Bomba de agua	NB 2	310414
632138530094	Múltiple escape	NFT 12	310416
623208520034	Salida de escape	NFT 1	320818
922208530134	Placa bomba de agua	NB 1	310419
922508500014	Junta	NB 1	440036
922208330024	Base filtro aceite	NB 1	310437
632508530054	Tapa trasera bancada	NB 1	310438
	Complemento cárter	NB 2	310539
922508530014	Tapa carcasa intercambiador	NB 1	440040
	Complemento cárter	NB 2	310540
90411025515	Acople caño escape	NB 1	310541
620508530124	Bomba inyectora	NB 1	310443
922508510014	Acople salida de escape	NFT 1	310445
632488510144	Fijación filtro aire	NB 1	310448
604931301124	Suplemento camisa cilindros G110 x 4	V 12	310470
	O'ring G 42.2 x 3	GS 2	
	O'ring G 45 x 3	GS 1	
	O'ring G 20 x 4	GS 1	
	O'ring G 18.77 x 1.78	GS 6	
	O'ring G 6 x 2	GS 1	
	O'ring G 30.8 x 3.7	GS 1	
	Arandela A 22 x 27 x 1.5 C	CU 1	
904920101418	Arandelas A 14 x 18 x 1.5 A	AL 16	
	Arandelas A 12 x 18 x 1.5 A	AL 2	
90492010081	Arandelas A 8 x 14 x 1 A	AL 3	
	Arandelas A 10 x 14 x 1 C	CU 1	
904960182227	Arandelas A 20 x 26 x 1 A	AL 1	
9069012081017	Arandelas A 10 x 20 x 1 C	CU 6	
	Jgo. retén válvulas (12)	V	R310410V
	Retén bancada 110 x 130 x 13	P 1	R310411P
	Retén distribución 78 x 100 x 13	V 1	R310412V

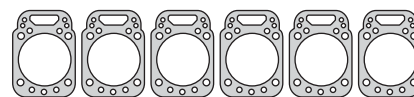

320807



310531

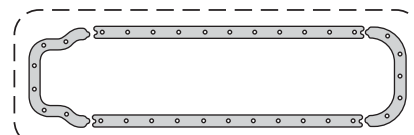

310511

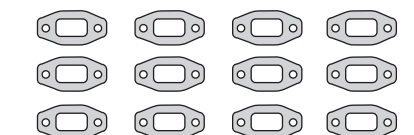

310416

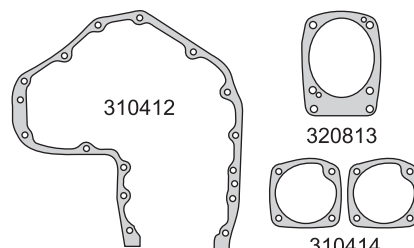

310412

320813

310414

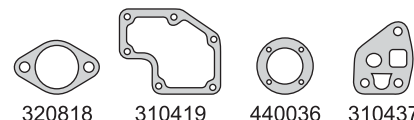

320818

310419

440036

310437

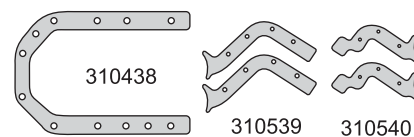

310438

310539

310540

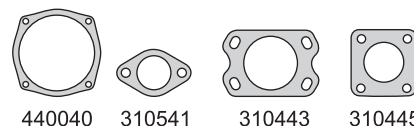

440040

310541

310443

310445

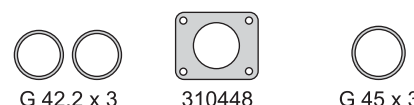

G 42.2 x 3

310448

G 45 x 3

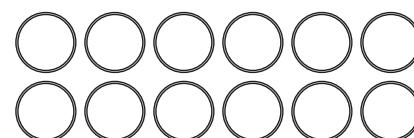

310470



G 20 x 4

G 18.77 x 1.78

G 6 x 2



G 30.8 x 3.7

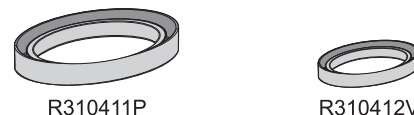

R310411P

R310412V

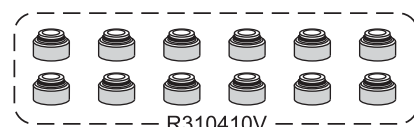

R310410V

MWM

PERKINS



Motor/Engine	Cm³	HP	Ø
4.203-P4-192Z	3336	71	91.49

Dodge: D100 - D200 1987/...
Ford: F100 - Falcon 1970/...

DIESEL

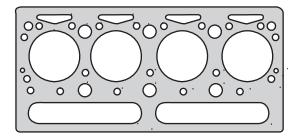

400008

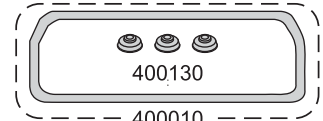

400130

400010

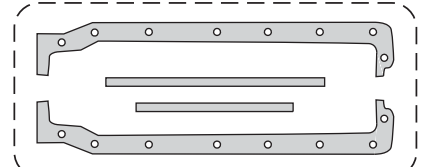

400011

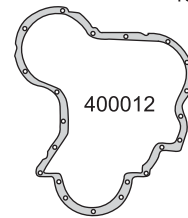

400012

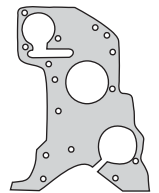

400013



400014

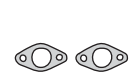

400015



400018



400017



400033



400034

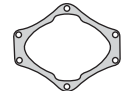

400035

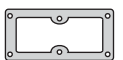

400036



400037



400039



400045

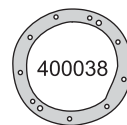

400038



400140



400146



400047



400051



400048

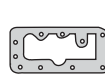

400052



400153



400057



400059



400062



400066



400165



400158



R400211P



R400012P



R300310P



R400010P

Nº OE	Descripción/Description	Mat.	Ref.
105379	Jgo. de juntas para motor		400000-R
	Jgo. de juntas superior		400095
	Jgo. de juntas superior		400095/7
	Junta tapa cilin. Ø 92.5 ± 1.40		400005
36812125	Junta tapa cilin. Ø 92.5 ± 1.40	NFT	400007
36812125	Junta tapa cilin. Ø 92.5 ± 1.15	CNC	400008
	Jgo. tornillos tapa cilindros (HAS19038)		B400000
0490704	Conjunto junta tapa válvulas (4)	CG	400010
003248	Jgo. junta para cárter (4)	NB	400011
006072	Tapa distribución	NB	400012
36814112	Block caja distribución	NB	400013
36866417	Bomba agua placa trasera	NB	400014
006002	Múltiple escape	FCH	400015
006061	Múltiple admisión	NFT	400017
0490032	Salida de escape	FCH	400018
	Arandela tapa válvulas	GS	400130
	Arandela base inyector A 14 x 20 x 1.5 C	CU	400033
33825409	Tapa frontal a tapa inspección	NB	400034
066081	Tapa trasera cigüeñal	NB	400035
0490485	Tapa trasera tapa cilindro	NB	400036
0066054	Tapa precámara combustible	CU	400037
006054	Precámara combustión	AL	410037
33826111	Porta retén bancada trasera	NB	400038
36866416	Caja distribución bomba vacío	NB	400039
0490867	Tapa trasera termoarranque	CG	400140
36853105	Caja distribución tapa toma fuerza	NB	400045
0490685	Comando bomba combustible	NB	400146
0490699	Tapa trasera árbol levas	NB	400047
0490692	Conexión entrada agua	NB	400048
36835411	Conexión salida agua	NB	400051
0490024	Salida agua a tapa	NB	400052
0490391	Cuerpo codo paso agua	NB	400153
006007	Filtro aceite a block	NB	400057
36883106	Jgo. juntas bancada cigüeñal (2)	SLA	400158
	Junta base depresor	NB	400059
36866428	Bomba vacío tapa brida	NB	400062
006074	Bomba alimentación combustible	NB	400165
36865543	Soporte bomba inyectora	NB	400066
	Kit de arandelas (57)	VS	400075
	Arandela A 10 x 14 x 1 A	AL	15
	Arandela A 13 x 20 x 1 A	AL	10
	Arandela A 17.5 x 22 x 1 A	AL	10
	Arandela A 19 x 27 x 2 A	AL	1
	Arandela A 8 x 12.5 x 1 A	AL	15
	Arandela A 14.5 x 20.5 x 1.5 C	CU	6
	Kit de retenes completo 4.203 hasta 1987		R400000
	Kit de retenes completo 4.203 1988/...		R400000-1
	Jgo. retén válvulas (8)	P	R300310P
	Jgo. retén válvulas (8)	P	R400010P
	Retén bancada 133.35 x 158.75 x 11/13	P	R400211P
	Retén distribución 60.32 x 79.36 x 9.5	P	R400012P

PERKINS

PERKINS



Motor/Engine	Cm³	HP	Ø
6.305 Cadenero	5004	100	91.44

Dodge: DP 400/500 1964/...
Ford: F350/600



DIESEL

Nº OE	Descripción/Description	Mat.	Ref.
005016	Jgo. de juntas para motor		400100-R
	Jgo. de juntas superior	●	400195
	Jgo. de juntas superior		400195/7
36812511	Junta tapa cilindros Ø 93 ± 1.40	NFT	400107
36812511	Junta tapa cilindros Ø 93 ± 1.15	CNC	400108
0490769	Conj. junta tapa válvulas (5)	CG	400110
0490018	Jgo. junta para cárter (4)	NB	400111
0490005	Tapa frontal distribución	NB	400112
0490002	Tapa distribución a block	NB	400113
36866417	Bomba de agua placa trasera	NB	400014
0490028	Múltiple escape	FCH	400015
0490026	Jgo. múltiple admisión (2)	NFT	400117
0490032	Salida de escape	FCH	400018
	Arandela tapa válvulas	GS	400130
0490632	Base inferior caja distribución	NB	400131
0490756	Block a soporte bomba vacío	NB	400132
0920113	Arandela base inyector A 14 x 20 x 1.25 C	CU	400033
36817134	Tapa trasera cigüeñal	NB	400035
0490485	Tapa trasera tapa cilindros	NB	400036
006054	Precámara combustión	CU	400037
0490003	Tapa inferior distribución	NB	400138
0490011	Tapa reguladora aceite block	NB	400139
0490687	Tapa trasera termoarranque	CG	400140
0490013	Tapa superior comando auxiliar	NB	400141
0490685	Codo bomba combustible	NB	400146
	Block tapa trasera	NB	400047
	Block con entrada de agua	NB	400048
0490234	Soporte bomba vacío	NB	400149
36835411	Conexión salida agua	NB	400051
0490024	Salida agua a tapa	NB	400052
0490391	Cuerpo codo paso agua	NB	400153
0490025	Múltiple entrada agua	NB	400156
	Filtro aceite a block	NB	400057
0490187	Cuerpo bomba aceite a block	NB	400157
36883106	Jgo. juntas retén aceite cigüeñal (2)	SLA	400158
0490007	Tubo carga aceite	NB	400159
	Junta base depresor	NB	400059
36851106	Soporte bomba vacío	NB	400163
36861719	Bomba vacío bomba combustible	NB	400164
36862126	Bomba alimentación combustible	NB	400165
0490012	Caja comando auxiliar a distribución	NB	400167
0490020	Depósito cárter	NB	400168
0490027	Múltiple admisión a conexión	NB	400169
	Kit de arandelas (57)	VS	400175
002251	Tapa frontal bomba vacío	NB	400186
	Arandela A 10 x 14 x 1 A	AL	15
	Arandela A 13 x 20 x 1.25 A	AL	10
	Arandela A 17 x 22 x 1 A	AL	10
	Arandela A 19 x 27 x 2 A	AL	1
	Arandela A 8 x 12 x 1 A	AL	15
	Kit de retenes completo		R400100
	Jgo. retén válvulas (12)	P	R540210P
	Jgo. retén válvulas (12)	P	R400110P
	Retén distribución 60.32 x 79.36 x 9.5	P	R400012P

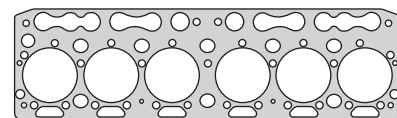

400108

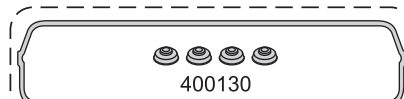

400130

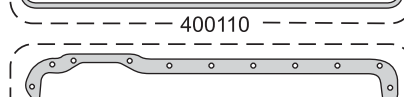

400110

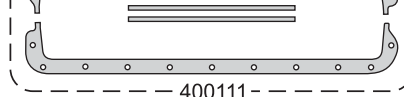

400111

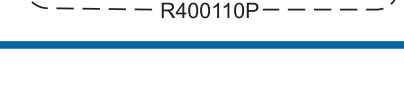
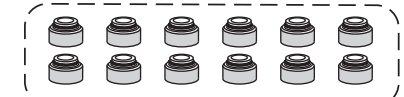
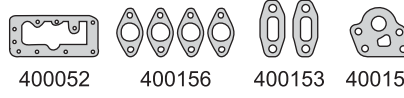
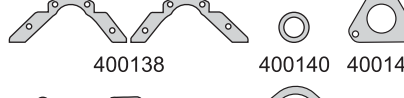
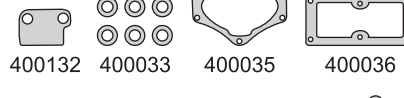
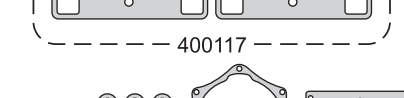
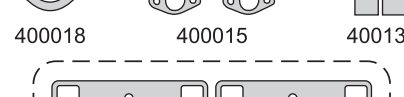
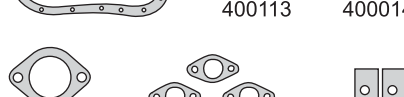
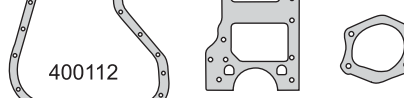
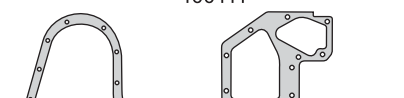

PERKINS



Motor/Engine	Cm³	HP	Ø
6.354-2	5798	140	98.47

Dodge: DP 600/800 1968/...
Ford: F600/700



DIESEL

Nº OE	Descripción/Description	Mat.	Ref.
	Jgo. de juntas para motor		400200-R
	Jgo. de juntas superior		400295
	Jgo. de juntas superior		400295/7
36812545	Junta tapa cilindros Ø104 \pm 1.50	NFT	400207
36812545	Junta tapa cilindros Ø104 \pm 1.30	CHA	400208
	Jgo. tornillos tapa cilin. (HAS19038)		B400200
36811412	Junta tapa válvulas	CG	400210
36816702	Junta para cárter	NB	400211
368114124	Distribución a block	NB	400212
36867108	Bomba de agua a block	NB	400214
	Jgo. múltiple escape (3)	FCH	400215
	Jgo. múltiple admisión (4)	NFT	400217
0490301	Salida de escape	FCH	400218
36847319	Depósito cárter chico	NB	400233
36816702	Junta para cárter (1.00 mm.)	NB	400234
36816702	Junta para cárter (0.08 mm.)	NB	400235
0490485	Tapa trasera tapa cilindros	NB	400036
36817157	Porta retén bancada trasera	NB	400236
003202	Base filtro aceite cámara	NB	400237
002794	Base filtro aceite	NB	400238
36831118	Válvula reguladora a block	NB	400239
0490687	Tapa trasera termoarranque	CG	400140
	Jgo. juntas compresor tensa bicil.	VS	400240
36846408	Inspección botadores	NB	400242
32811408	Lateral puente a block	GS	400442
36826107	Tapa inspección engranaje árbol de levas	CG	400243
36866434	Inspección engranaje comando auxiliar	NB	400244
002038	Vaso pre-filtro	CG	400045
	Vaso combustible	CG	450045
33828108	Comando bomba combustible	NB	400246
36832118	Brida caño succión a bomba	NB	400249
36866426	Acople compresor a block	NB	400250
36846113	Cuerpo salida agua tapa cilindros	NB	400254
	Jgo. empaquetadura cigüeñal (2)	SLA	400158
	Junta tapa válvulas superior	CG	400261
36862126	Bomba alimentación combustible	NB	400165
006090	Bomba alimentación combustible	NB	400465
	Placa cuerpo múltiple admisión	NB	400282
36867132	Porta retén bancada trasera	NB	400283
36817136	Placa adaptador bomba inyección	NB	400284
36822118	Arandela inyector A 10 x 19 x 2 C	CU	6
	Arandela A 10 x 14 x 1.5 A	AL	15
	Arandela A 13 x 21 x 2 A	AL	15
	Arandela A 17 x 22 x 1.5 A	AL	5
	Arandela A 19 x 27 x 2 A	AL	1
105393	Arandela A 8 x 13 x 1.5 A	AL	15
	Kit de retenes completo		R400200-1
	Jgo. retén válvulas (12)	P	R400210P
	Retén bancada 133.35 x 158.75 x 11/13	V	R400211V
	Retén distribución 60.32 x 79.36 x 9.5	P	R400012P
	Retén auxiliar 22.22 x 35.70 x 9.52	N	R400215N

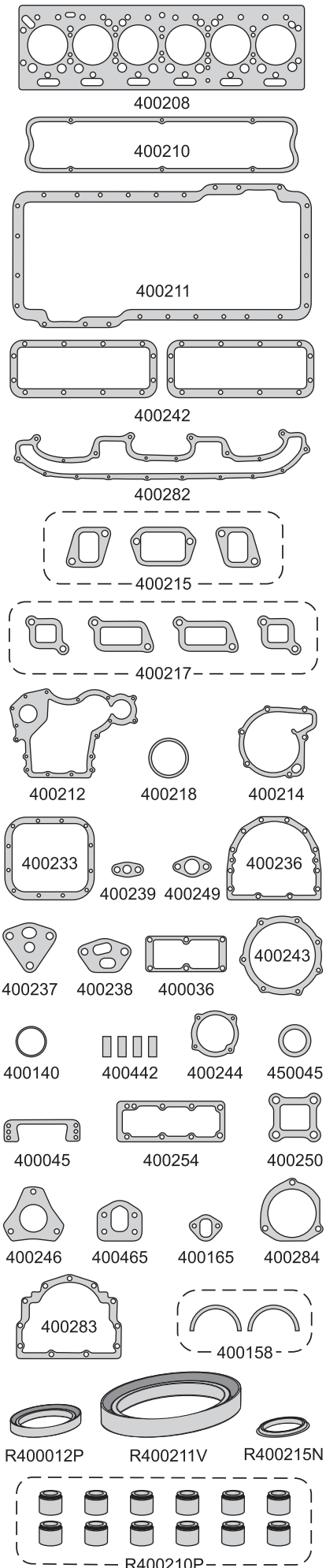

PERKINS

PERKINS



Motor/Engine	Cm³	HP	Ø
6PF - 305	5004	102	91.44

Ford: F100 - F350 - F600 1974/...

DIESEL



Nº OE	Descripción/Description	Mat.	Ref.
105388	Jgo. de juntas para motor		400300-R
	Jgo. de juntas superior		400395
	Jgo. de juntas superior		400395/7
006063	Jta. tapa cilindros Ø 92.5 x 1.40	NFT	400307
006063	Jta. tapa cilindros Ø 92.5 x 1.25	FCH 1 1	400308
	Jgo. tornillos tapa cilindros (HAS19038)		B400300
0490760	Conj. junta tapa válvulas (4)	CG 1 1	400110
006000	Jgo. junta para cárter (4)	NB 1	400311
006072	Caja distribución tapa frontal	NB 1	400012
36814112	Block caja distribución	NB 1	400013
36866417	Bomba agua placa trasera	NB 1	400014
006002	Múltiple escape	FCH 3 3	400015
0490026	Jgo. múltiple admisión (2)	NFT 1 1	400117
0490032	Salida de escape	FCH 1 1	400018
	Arandela tapa válvulas (4)	GS 4 4	400130
0920113	Arandela base inyector A 14 x 20 x 1.25 C	CU 6	400033
33825409	Tapa frontal tubo venteo	NB 1	400034
006081	Tapa trasera cigüeñal	NB 1	400035
0490458	Tapa trasera tapa cilindros	NB 1 1	400036
006054	Precámara combustión	CU 6 6	400037
006054	Precámara combustión	AL	410037
33826111	Porta retén bancada trasera	NB 1	400038
36866416	Caja distribución bomba vacío	NB 1	400039
	Válvula reguladora a block	NB 1	400239
	Junta tapa trasera	CG 1	400140
36853105	Caja distribución tapa toma fuerza	NB 1	400045
0490685	Comando bomba combustible	NB 1	400146
0490699	Block tapa trasera	NB 1	400047
0490692	Conexión entrada agua	NB 1	400048
002742	Caño aceite a block	NB 1	400249
36835411	Conexión salida agua	NB 1 1	400051
0490024	Salida agua a tapa	NB 1 1	400052
0490391	Cuerpo codo paso agua	NB 2	400153
006007	Filtro aceite a block	NB 1	400057
36883106	Jgo. juntas bancada cigüeñal (2)	SLA 1	400158
36866428	Bomba vacío a tapa distribución	NB 1	400062
006074	Bomba vacío a bomba combustible	NB 1	400165
36865543	Soporte bomba inyectora	NB 1	400066
	Placa bomba agua	NB	400363
	Kit de arandelas (57)	VS 1	400175
	Arandela A 10 x 14 x 1 A	AL 15	
	Arandela A 13 x 20 x 1.25 A	AL 10	
	Arandela A 17 x 22 x 1 A	AL 10	
	Arandela A 19 x 27 x 2 A	AL 1	
	Arandela A 8 x 12 x 1 A	AL 15	
	Kit de retenes completo		R400300
	Jgo. retén válvulas (12)	P 1	R540210P
	Jgo. retén válvulas (12)	P 1	R400110P
	Retén bancada 133.35 x 158.75 x 11/13	P 1	R400211P
	Retén distribución 60.32 x 79.36 x 9.5	P 1	R400012P

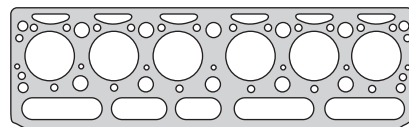

400308

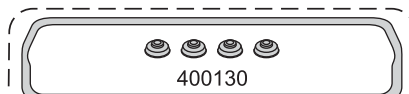

400130

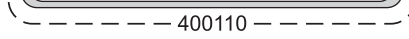

400110

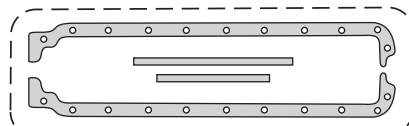

400311

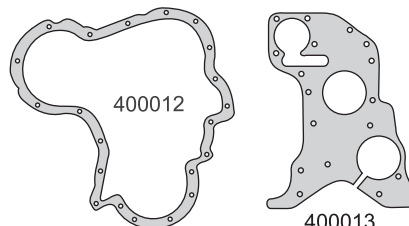

400012

400013



400015

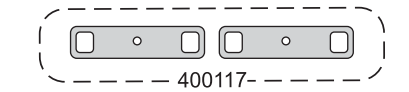

400117

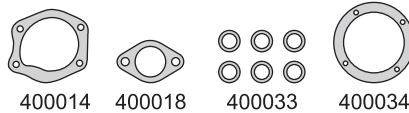

400014

400018

400033

400034

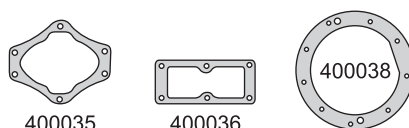

400035

400036

400038

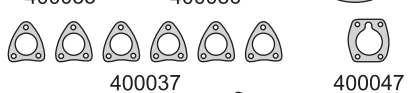

400037

400047

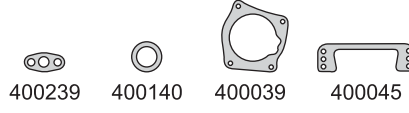

400239

400140

400039

400045

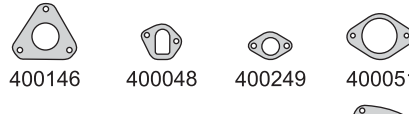

400146

400048

400249

400051

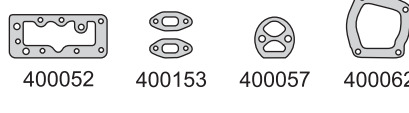

400052

400153

400057

400062

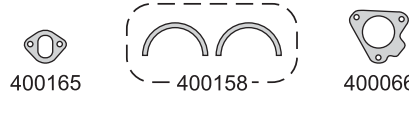

400165

400158

400066

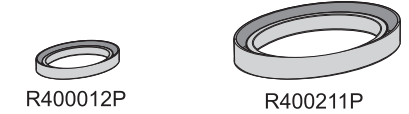

R400012P

R400211P

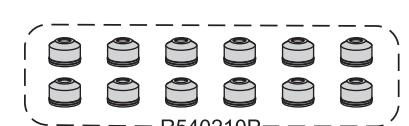

R540210P



R400110P

PERKINS

PERKINS



Motor/Engine	Cm³	HP	Ø
6.354-4 Turbo	5798	172	98.42

Dodge: D600/800 1976/...
Ford: F7000 Camiones
 Ford pesados y semi-pesados



DIESEL

Nº OE	Descripción/Description	Mat.	Ref.
105683	Jgo. de juntas para motor		400400-R
	Jgo. de juntas superior	●	400495
	Jgo. de juntas superior		400495/7
	Junta tapa cilindros Ø104 \pm 1.50	NFT	400407
36812607	Junta tapa cilindros Ø104 \pm 1.45	CHA	1 1 400408
	Jgo. tornillos tapa cilindros (HAS19038)		B400200
006104	Conj. junta tapa válvulas (5)	CG	1 1 400410
006088	Junta para cárter	NB	1 400411
36814124	Caja distribución a bock	NB	1 400212
36867162	Bomba de agua a block	NB	1 400414
	Jgo. múltiple escape (3)	AC	1 1 400416
	Jgo. múltiple admisión (4)	AC	1 1 400417
37481108	Salida de escape	AC	2 2 400418
36865532	Bomba aceite a bock	NB	1 400427
36833125	Bomba carga aceite	CG	3 3 400429
36831122	Válvula reguladora presión aceite	NB	1 400430
36832133	Caño aceite turbo	NB	2 400431
36833148	Drenaje aceite turbo	NB	1 400432
36861448	Adaptador alimentación aceite	NB	1 400433
	Base filtro óleo	NB	1 410433
36861745	Conexión salida agua	NB	1 1 400434
36834143	Bomba inyectora	NB	1 400435
0490485	Tapa trasera tapa cilindros	NB	1 1 400036
36817157	Porta retén trasero	NB	1 400236
006095	Cabezal a block	NB	1 400437
36823132	Tapa múltiple codo a múltiple admisión	NB	2 400438
36821118	Entrada agua a block	NB	1 400439
0490474	Caño ventilación a tapa válvulas	NB	1 400440
0490053	Tapa cierre	NB	2 400441
32811408	Lateral puente a block	GS	4 400442
36826107	Tapa inspección engranaje árbol de levas	CG	1 400243
36866434	Tapa inspección engranaje comando auxiliar	NB	1 400244
36833139	Caño bomba de aceite	NB	1 400444
	Drenaje turbo	NB	350445
	Arandela cierre tapa de válvulas	GS	4 4 400446
006089	Cabezal a block	NB	1 400447
36866426	Compresor a block	NB	1 400250
36846113	Cuerpo salida agua	NB	1 1 400254
	Colector a turbo escape	AC	350462
006090	Bomba alimentadora a bock	NB	1 400465
36822118	Placa adaptador a block	NB	1 400284
	Arandela A 10 x 20 x 1 C	CU	6 6
	Arandela A 7 x 10 x 1 A	AL	12
	Kit de retenes completo		R400200-1
	Jgo. retén válvulas (12)	P	1 R400210P
	Retén bancada 133.35 x 158.75 x 11/13	V	1 R400211V
	Retén distribución 60.32 x 79.36 x 9.5	P	1 R400012P
	Retén auxiliar 22.22 x 35.70 x 9.52	N	1 R400215N

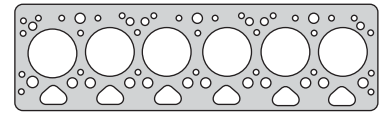

400408

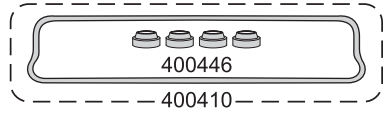

400446

400410

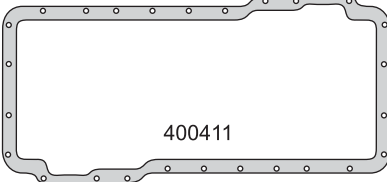

400411

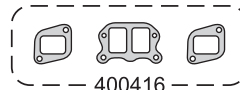

400416

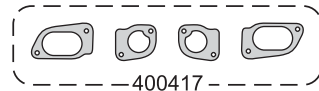

400417

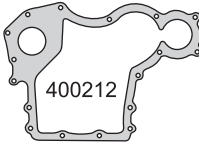

400212

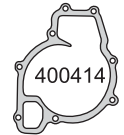

400414

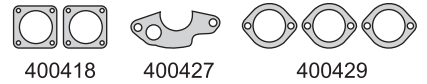

400418

400427

400429



400430

400431

400432

410433

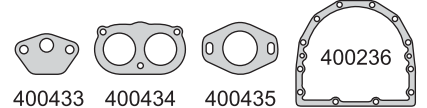

400433

400434

400435

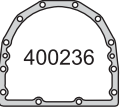

400236

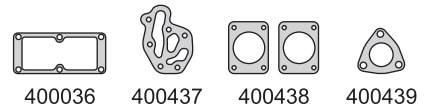

400036

400437

400438

400439

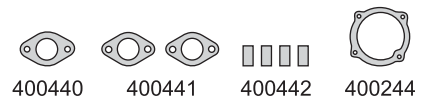

400440

400441

400442

400244



400243

400444

400254



400465

400250

400284



A 7 x 10 x 1 A



A 10 x 20 x 1 C

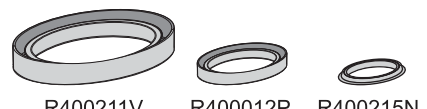

R400211V

R400012P

R400215N

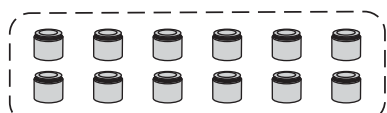

R400210P

PERKINS

PERKINS



Motor/Engine	Cm³	HP	Ø
P3 - 152	2362	42	91.44

Perkins: Tractor Viñatero



DIESEL

Nº OE	Descripción/Description	Mat.	Ref.
105377	Jgo. de juntas para motor	●	400500-R
368112122	Junta tapa de cilindros Ø 93 ± 1.45	NFT	400507
368112122	Junta tapa de cilindros Ø 93 ± 1.45	FCH 1	400508
	Jgo. tornillos tapa cilindros (HAS19038)		B400000
0490491	Conj. tapa válvulas superior (3)	CG 1	400510
003249	Jgo. junta para cárter (4)	NB 1	400511
002476	Tapa distribución	NB 1	400512
36814119	Placa distribución	NB 1	400513
36866417	Bomba de agua a placa	NB 1	400014
0490481	Múltiple escape	FCH 2	400015
0490032	Salida de escape	FCH 1	400018
	Arandela tapa válvulas	GS 2	400130
	Depósito cárter	NB 1	400533
0490482	Cuerpo salida agua	NB 1	400534
006081	Tapa trasera cigüeñal	NB 1	400035
002477	Bomba hidráulica toma fuerza	CB 1	400535
0490485	Tapa trasera tapa cilindros	NB 1	400036
0490738	Cuerpo salida agua tapa cilindros	NB 1	400536
006054	Precámara combustión	CU 3	400037
36862511	Tapa trasera árbol levas	NB 1	400537
006054	Precámara combustión combustible	AL	410037
	Base filtro aceite	NB 1	400237
0490686	Cuerpo toma aire	NB 2	400538
0490486	Tapa conexión entrada aire	NB 1	400539
0490687	Tapa trasera termoarranque	CG 1	400140
36862512	Tapa inspección carga aceite	NB 1	400540
36862165	Bomba alimentación	NB 1	400541
002478	Tapa inspección engranaje distribución	NB 1	400542
36853105	Caja a tapa toma fuerza	NB 1	400045
0490685	Comando bomba combustible	NB 1	400146
36835411	Conexión salida agua	NB 1	400051
0490391	Cuerpo codo paso agua	NB 1	400153
006047	Filtro aceite a block	NB 1	400057
36883106	Jgo. juntas bancada cigüeñal (2)	SLA 1	400158
36851106	Soporte bomba vacío	NB 1	400163
006074	Bomba alimentación combustible	NB 1	400165
	Arandela inyector A 14 x 20 x 1.5 C	CU	
	Kit de retenes completo		R400500
	Jgo. retén válvulas (6)	P 1	R400010P
	Jgo. retén válvulas (6)	P 1	R300310P
	Retén bancada 133.35 x 158.75 x 11/13	P 1	R400211P
	Retén distribución 60.32 x 79.36 x 9.5	P 1	R400012P

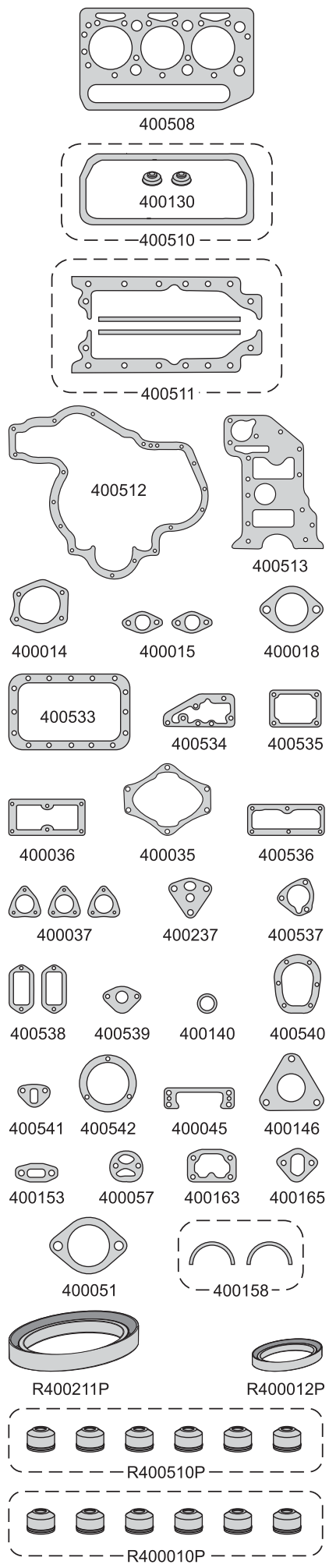

PERKINS

PERKINS



Motor/Engine	Cm³	HP	Ø
6PF - MF1175	5004	100	91.44

Massey Ferguson: Tractor - PF



DIESEL

Nº OE	Descripción/Description	Mat.	Ref.
	Jgo. de juntas para motor		400600-R
006063	Junta tapa cilindros Ø 92.5 ± 1.40	NFT	400307
006063	Junta tapa cilindros Ø 92.5 ± 1.25	FCH	400308
	Jgo. tornillos tapa cilindros (HAS19038)		B400300
0490760	Conj. tapa válvulas superior (5)	CG	400110
006080	Jgo. junta para cárter (4)	NB	400611
006013	Caja distribución tapa frontal	NB	400612
36814112	Block caja distribución	NB	400013
36866417	Bomba de agua placa trasera	NB	400014
006002	Múltiple escape	FCH	400015
0490026	Jgo. múltiple admisión (2)	NFT	400117
0490032	Salida de escape	FCH	400018
	Arandela tapa válvulas	GS	400130
	Brida bomba hidráulica	NB	400631
0920113	Arandela base inyector A 14 x 20 x 1.25 C	CU	400033
33825409	Tapa frontal tubo venteo	NB	400034
	Tapa trasera cigüeñal	NB	400035
	Tapa trasera cigüeñal	NB	400635
0490485	Tapa trasera tapa cilindros	NB	400036
006054	Precámara combustión	CU	400037
006054	Precámara combustión combustible	AL	410037
	Base filtro aceite	NB	400237
0490867	Tapa trasera termoarranque	CG	400140
36853105	Caja distribución tapa toma fuerza	NB	400045
0490685	Codo bomba combustible	NB	400146
0490699	Block tapa trasera	NB	400047
0490692	Block conexión entrada agua	NB	400048
002742	Caño paso aceite a block	NB	400249
	Jgo. juntas caja velocidad	VS	400650
36835411	Conexión salida agua	NB	400051
0490024	Salida agua a tapa	NB	400052
0490391	Cuerpo codo paso agua	NB	400153
006007	Filtro aceite a block	NB	400057
36883106	Jgo. juntas bancada cigüeñal (2)	SLA	400158
36866428	Bomba vacío tapa brida	NB	400062
006074	Bomba alimentación combustión	NB	400165
36865543	Soporte bomba inyectora	NB	400066
	Kit de arandelas (57)	VS	400175
	Arandela A 10 x 14 x 1 A	AL	15
	Arandela A 13 x 20 x 1.25 A	AL	10
	Arandela A 17 x 22 x 1 A	AL	10
	Arandela A 19 x 27 x 2 A	AL	1
	Arandela A 8 x 12 x 1 A	AL	15
	Arandela tapón cárter A 19 x 27 x 2 A	AL	
	Kit de retenes completo		R400300
	Jgo. retén válvulas (12)	P	1 R400110P
	Jgo. retén válvulas (12)	P	1 R540210P
	Retén bancada 133.35 x 158.75 x 11/13	P	1 R400211P
	Retén distribución 60.32 x 79.36 x 9.5	P	1 R400012P

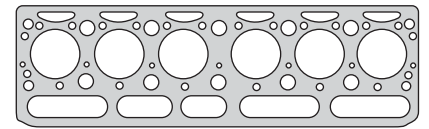

400308

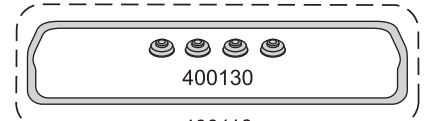

400130

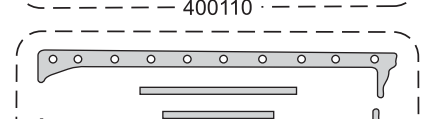

400110

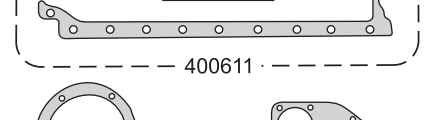

400611

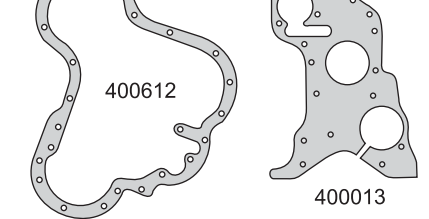

400612

400013



400015

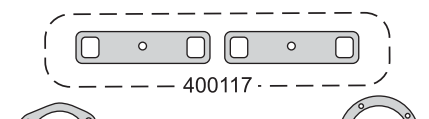

400117

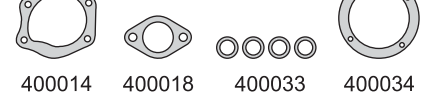

400014

400018

400033

400034

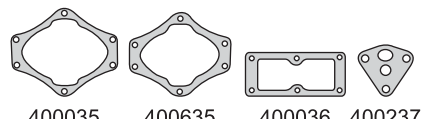

400035

400635

400036

400237



400037

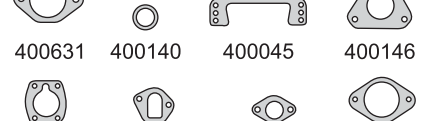

400631

400140

400045

400146

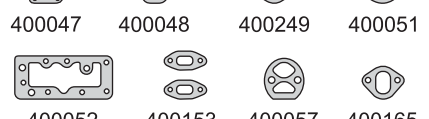

400047

400048

400249

400051

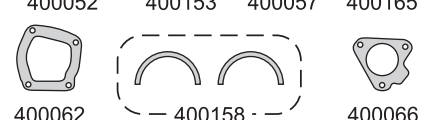

400052

400153

400057

400165



400062

400158

400066

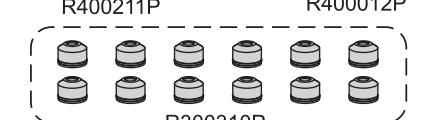

R400211P

R400012P



R300310P

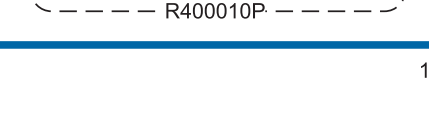

R400010P

PERKINS

PERKINS



Motor/Engine	Cm³	HP	Ø
6.354-1	5798	135	98.43

Dodge: DP 600/800
Ford: F600 - F700



DIESEL

Nº OE	Descripción/Description	Mat.	Ref.
	Jgo. de juntas para motor		400900-R
	Junta tapa cilindros Ø 104 ± 1.45	NFT 1	400907
	Jgo. tornillos tapa cilindros (HAS19038)		B400200
36811412	Junta tapa válvulas superior	CG 1	400210
36816702	Junta para cárter	NB 1	400211
36814124	Distribución a block	NB 1	400212
36867108	Bomba de agua a block	NB 1	400214
	Jgo. múltiple escape (3)	FCH 1	400215
	Jgo. múltiple admisión (4)	NFT 1	400217
0490301	Salida de escape	FCH 1	400218
36847319	Depósito cárter chico	NB 1	400233
36816702	Junta para cárter (1.00 mm)	NH	400234
36816702	Junta para cárter (0.08 mm)	NH	400235
0490485	Tapa trasera tapa cilindros	NB 1	400036
003202	Base filtro aceite	NB 1	400237
	Base filtro aceite	NB 1	400238
36831118	Válvula reguladora a block	NB 1	400239
0490687	Tapa trasera termoarranque	CG 1	400140
36846408	Inspección botadores	NB 2	400242
32811408	Lateral puente a block	GS 4	400442
36826107	Tapa inspección engranaje árbol de levas	CG 1	400243
36866434	Inspección engranaje comando auxiliar	NB 1	400244
002038	Vaso pre-filtro	CG 1	450045
0490685	Comando bomba combustible	NB 1	400146
36832118	Brida caño succión a bomba	NB 1	400249
368866424	Acople compresor a block	NB 1	400250
36846113	Cuerpo salida agua tapa cilindros	NB 1	400254
	Jgo. juntas empaquetadura bancada (2)	SLA 1	400158
36862126	Bomba alimentación combustible	NB 1	400165
	Junta base bomba alimentación	NB 1	400465
	Jgo. juntas compresor Burmor	VS	800069
	Kit de arandelas (57)	VS 1	400275
36867132	Placa cuerpo múltiple admisión	NB 1	400282
36817136	Porta retén bancada trasera	NB 1	400283
36822118	Placa adaptador bomba inyección	NB 1	400284
	Arandela inyector A 10 x 19 x 2 C	CU 6	
	Arandela A 10 x 14 x 1.5 A	AL 15	
	Arandela A 13 x 20.5 x 2 A	AL 15	
	Arandela A 17 x 22 x 1.5 A	AL 5	
	Arandela A 19 x 27 x 2 A	AL 1	
	Arandela A 8 x 12.5 x 1.5 A	AL 15	
	Kit de retenes completo		R400900
	Jgo. retén válvulas (12)	P 1	R400210P
	Retén distribución 60.32 x 79.36 x 9.5	P 1	R400012P
	Retén auxiliar 22.22 x 35.70 x 9.52	N 1	R400215N

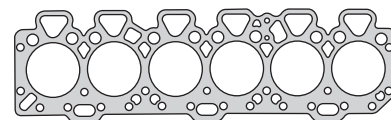

400907



400210

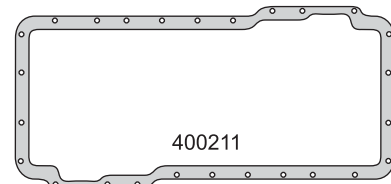

400211

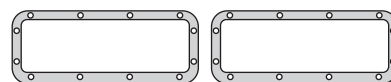

400212

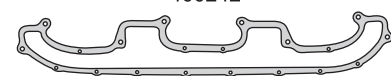

400214



400215

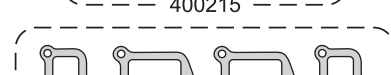

400217

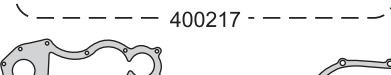

400218



400219

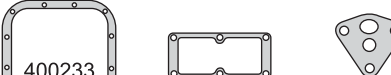

400233



400036



400237



400238



400239

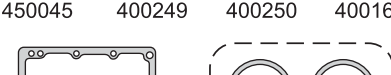

400140



400442



400243

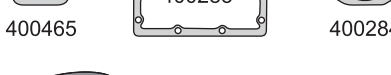

400244



400146

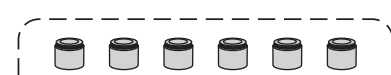

450045



400249



400250

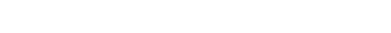

400165

400254

400158

400465

400283

400284

R400012P

R400215N

R400210P

PERKINS

PERKINS



Motor/Engine	Cm³	HP	Ø
Q20B4 Iny. Directa	3860	70	98.4

Chevrolet: GM D20

DIESEL

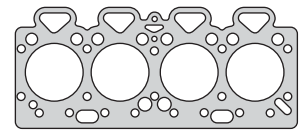

410607

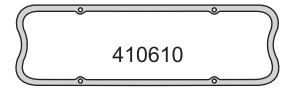

410610

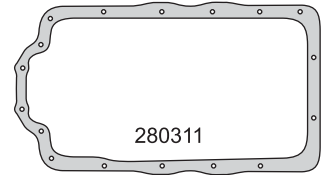

280311



410616

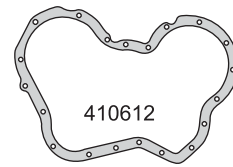

410612

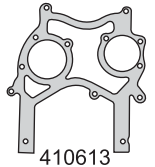

410613



410614

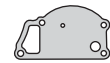

410619



400218 410630

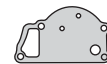

410631

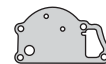

410731

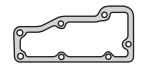

410632

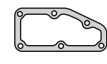

410633



410634



400435



410635



400236



410636



410637



410638



410639



410640



410641



410642



400442



410643



410644



400244



400146



410546



410645



410747



400062



410649



410650



410651



410652



410653

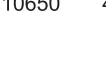

410654



R400211P



R400012P



R300310P

Nº OE	Descripción/Description	Mat.	Ref.
424801/423607	Jgo. de juntas para motor		401000-R
	Jgo. de juntas superior		401095
36812338	Jta. tapa cilindros Ø 104 \pm 1.70	NFT	1 1 410607
70490149	Junta tapa válvulas	CG	1 1 410610
70490178	Junta para cárter	CG	1 1 280311
36813138	Tapa distribución	NB	1 1 410612
36814127	Placa distribución	NB	1 1 410613
36866724	Tapa bomba de agua trasera	NB	1 1 410614
36862134	Múltiple escape	FCH	2 2 410616
0490301	Salida de escape	FCH	1 1 400218
70490144	Bomba de agua a block	NB	1 1 410619
36866416	Adaptador bomba vacio	NB	1 1 410630
70490146	Block a bomba de agua	NB	1 1 410631
36867156	Bomba de agua a block	NB	1 1 410731
36853514	Cuerpo salida agua	NB	1 1 410632
36851409	Tapa trasera tapa cilindros	NB	1 1 410633
36862517	Filtro lubricación block y placa	NB	2 2 410634
36834143	Bomba inyectora	NB	1 1 400435
0490734	Carcasa termostato	NB	1 1 410635
36817157	Porta retén bancada trasera	NB	1 1 400236
36862133	Múltiple admisión central	NB	1 1 410636
36862151	Conexión superior salida de agua	NB	1 1 410637
36862131	Múltiple admisión trasera	NB	1 1 410638
36866462	Múltiple admisión frontal	NB	1 1 410639
7049145	Cuerpo delantero y trasero bomba de agua	NB	1 1 410640
36835425	Carcasa a conexión superior	CG	1 1 410641
32811113	Bastón placa interior a block	GS	2 2 400442
36851113	Bomba alimentación a block	NB	1 1 410642
36832122	Tubo succión bomba aceite	NB	1 1 410643
36825107	Cierre inspección distribución	NB	1 1 400244
0490355	Tubo succión a válvula alimentación	NB	1 1 410644
36822111	Colector escape	NFT	2 2 410645
0490773	Comando bomba inyectora	NB	1 1 400146
70490100	Acoplamiento bomba inyectora	NB	1 1 410546
	Anillo lubricación tapa cilindros G 6.2 x 10.7 x 6	GS	1 1 400646
	Adaptador vacio	NB	1 1 410747
	Junta placa ventilación	NB	1 1 410649
	Junta base bomba de nafta	NB	1 1 410650
	Junta válvula alivio	NB	1 1 410651
	Junta válvula alivio	NB	1 1 410652
	Junta conexión	NB	1 1 410653
	Junta base bomba de nafta	NB	1 1 410654
	Bomba de vacio a brida	NB	1 1 400062
	Arandela A 10 x 20 x 2 C	CU	4 4
	Arandela A 10 x 14 x 1.5 A	AL	4
	Arandela A 14 x 20 x 1.5 A	AL	10
	Arandela A 20 x 26 x 1 A	AL	1
	Arandela A 8 x 10 x 1 A	AL	8
	O´ring G 21 x 35 x 13	GS	4 4
	Kit de retenes completo		R410600
	Jgo. retén válvulas (8)	P	1 R300310P
	Retén bancada 133.35 x 158.75 x 11/13	P	1 R400211P
	Retén distribución 60.32 x 79.36 x 9.5	P	1 R400012P

PERKINS

PERKINS MAXION



Motor/Engine	Cm³	HP	Ø
P4000-4000T	4100	72/86	100

Perkins: MF290/292/610/620



DIESEL

Nº OE	Descripción/Description	Mat.	Ref.
	Jgo. de juntas para motor		401100-R
	Jgo. de juntas superior	●	401195
3681E016	Junta tapa de cil. Ø 105 ± 1.80	NFT	1 1 280307
	Jgo. de tornillos para tapa de cilindros		B280300
7049258	Conj. junta tapa de válvulas (5)	N	1 1 280310
36815707	Junta para cárter	NB	1 1 401511
36813137	Tapa distribución	NB	1 1 410712
36814137	Placa distribución	NB	1 1 410613
	Bomba de agua	NB	1 1 420214
36886007	Jgo. múltiple escape (2)	NFT	1 1 280316
	Jgo. múltiple admisión (3)	NFT	1 1 280317
	Salida de escape	NFT	1 1 401118
C7NN-6659-A	Bomba aceite a block	NB	1 1 330030
	Junta conexión bomba de agua	NB	1 1 401131
36867156	Bomba agua a block	NB	1 1 410731
36853514	Cuerpo salida de agua	NB	1 1 410632
36851409	Tapa trasera tapa de cilindros	NB	1 1 410633
36862517	Filtro lubricación a block	NB	1 1 410634
36817157	Porta retén bancada trasero	NB	1 1 400236
36862151	Conexión superior salida de agua	NB	1 1 410637
36835428	Carcaza a conexión superior	CG	1 1 410641
32811113	Lateral puente a block	GS	2 2 400442
36832122	Tubo succión bomba aceite	NB	2 2 410643
36832404	Bomba succión aceite	NB	1 1 410743
36866434	Cierre inspección distribución	NB	1 1 400244
0490355	Junta tubo succión a válvula alimentación	NB	1 1 410644
36862138	Bocal lubricación	NB	1 1 410744
	Entrada aceite turbo	NB	420244
36822111	Múltiple escape	NFT	1 1 410645
	Block balanceador dinámico	NB	1 1 420245
	Arandela cierre tapa de válvulas	GS	4 4 400446
	Junta base bomba inyectora	NB	1 1 410650
	Bomba combustible	NB	410654
	Múltiple escape a turbo	AC	1 1 350462
70920104	Arandela base inyector A 7.5 x 15 x 2 C	CU	4 4
	Anillo lubricación tapa cilindros G 7.2 x 11 x 6	GS	1
	Kit de retenes completo		R410600
	Jgo. retén válvulas (8)	P	1 R300310P
	Jgo. retén válvulas (8)	P	1 R400210P
	Retén de bancada 133.35 x 158.75 x 11/13	V	1 R400211V
	Retén de distribución 60.32 x 79.36 x 9.5	P	1 R400012P

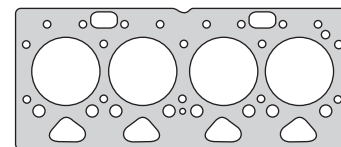

280307

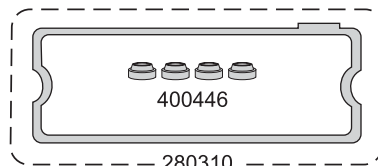

400446

280310

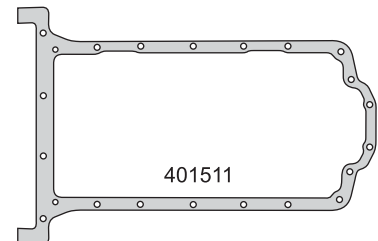

401511



280317

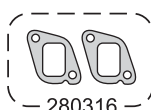

280316

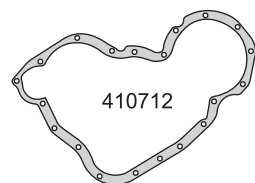

410712

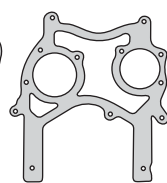

410613



420214



401118



330030



410634



401131

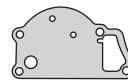

410731

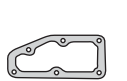

410633

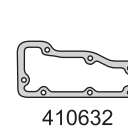

410632

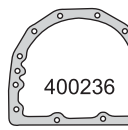

400236



410637



410641



400442



410643



420244



410744

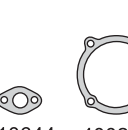

410644



400244



410743



410644



400244



410645



420245



410650



410654

350462



R400211V



R400012P

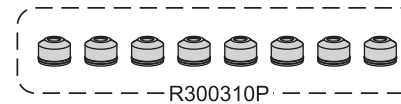

R300310P



R400210P

PERKINS



Motor/Engine	Cm³	HP	Ø
1004.4/T/TW	3990		100

Perkins: Phaser 90 - 4.40 - 110T - T4.40
Phaser 120 Ti - C4.40
MF6130/6140/6150



DIESEL

Nº OE	Descripción/Description	Mat.	Ref.
	Jgo. de juntas para motor		401500-R
3681E037	Junta tapa cilindros Ø 105 \pm 1.50	NFT 1	401507
	Jgo. de tornillos para tapa de cilindros		B401500
3681A021	Junta tapa válvulas	CG 1	401510
36815721	Junta para cárter	NB 1	401511
3681P011	Tapa distribución	NB 1	401512
3681P009	Placa distribución	NB 1	401513
3382P004	Tapa bomba de agua	NB 1	401514
3688C023	Múltiple escape	AC 1	401515
3688C029	Múltiple admisión	SLS 1	401517
3686C018	Salida de escape colector	AC 1	401518
3687H005	Toma fuerza	NB 1	401529
3685R005	Cuerpo salida de agua a termostato	NB 1	401532
3685F005	Tapa trasera tapa cilindros	NB 1	401533
36864004	Base filtro aceite	NB 1	410433
	Guarnición goma G 94.84 x 3.53	GS 1	401534
3684A004	Junta termostato	NB 1	401535
36817181	Porta retén bancada trasero	NB 1	401536
	Junta	NB 1	401537
3682H003	Caracol turbina	NB 1	401637
	Junta brida entrada aceite turbo	NB	401538
	Junta brida salida aceite turbo	NB	401539
	Cierre bancada trasera	GS 2	400442
	Junta bomba alimentación	NB 1	410642
3684N008	Junta turbo escape	NB 1	401542
36832143	Bomba aceite enfriador	NH	401643
	Junta succión a lubricación aceite	NB 1	410743
33828108	Base bomba inyectora	NB 1	400246
	Entre múltiple turbo	AC 1	500546
36834143	Base bomba inyectora	NB 1	401648
36885.005	Salida de escape turbo	AC 1	350462
0490706	Base bomba inyectora	NB 1	401566
	Anillo goma G 21 x 30 x 9	GS 4	
	Anillo goma G 4.5 x 8.5 x 6	GS 2	
	Arandela A 8 x 11 x 1A	AL 10	
	Arandela base inyector A 10 x 20 x 2 C	CU 4	
	Arandela A 10 x 14 x 1.25 A	AL 3	
	O'ring G 6 x 10 x 6	GS 10	
	Kit de retenes completo		R401500
	Jgo. retén válvulas (8)	P 1	R280310P
	Retén bancada 133.35 x 158.75 x 11/13	V 1	R400211V
	Retén distribución 60.32 x 79.36 x 9.5	V 1	R400012V

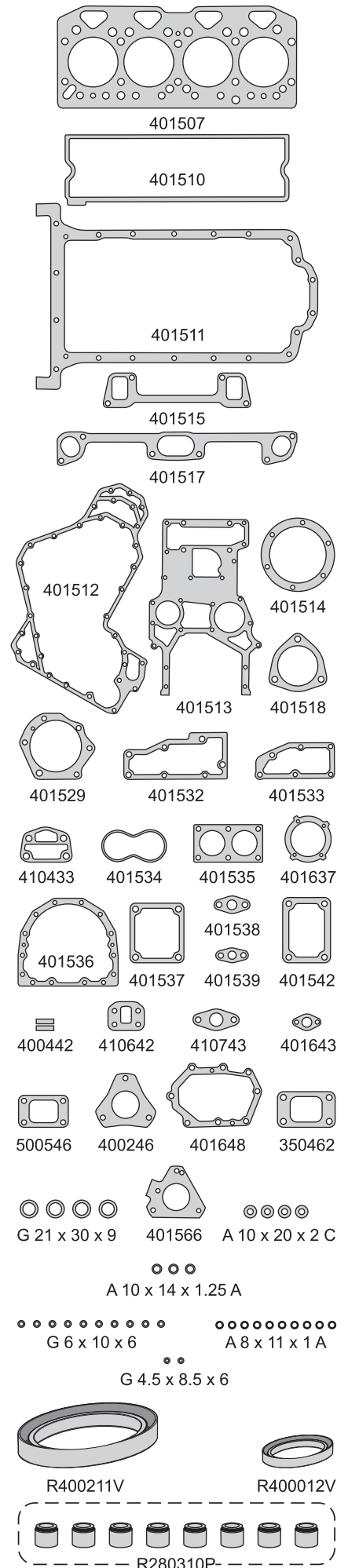

PERKINS

PERKINS



Motor/Engine	Cm³	HP	Ø
1006.6C/T/TW	5985		100

Perkins: Phaser 125 - MF396/399/630/640/3085
 6160/6170 - Phaser 160Ti - MF660/3114
 3125/3625/3635/3655/6189/6190/8110
 8120/8130 1989/...
 Phaser 180Ti 1989/...
 MF399 1994/...



DIESEL

Nº OE	Descripción/Description	Mat.	Ref.
	Jgo. de juntas para motor		401600-R
3681H208	Junta tapa cilindros Ø 105 ± 1.50	NFT	1 401607
3681C001	Junta tapa válvulas	CG	1 401610
3681M007	Junta para cárter	NB	1 401611
3681P011	Tapa distribución	NB	1 401512
3681P001	Placa distribución	NB	1 401513
3382P004	Tapa bomba de agua	NB	1 401514
3688C173	Jgo. múltiple escape (3)	AC	1 401615
	Jgo. múltiple admisión (4)	AC	1 400417
	Junta brida	NB	401627
3686T006	Bomba alimentación combustible	NB	1 401628
3687H005	Toma fuerza	NB	1 401529
36832138	Succión de aceite turbo	NB	401631
3685R005	Cuerpo salida agua termostato	NB	1 401532
3685F005	Tapa trasera tapa cilindros	NB	1 401533
	Base filtro aceite	NB	2 410433
	Guarnición goma G 94.84 x 3.53	GS	1 401534
3687W003	Filtro aceite a block	NB	1 401634
3684A004	Junta carcasa termostato	NB	1 401535
36817181	Porta retén bancada trasera	NB	1 401536
3687Y002	Filtro aceite a block	NB	1 401636
	Junta	NB	1 401537
3682H003	Junta caracol turbina	NB	1 401637
3734K021	Junta brida	NB	1 401638
3683D006	Junta brida salida turbo	NH	401539
	Junta	NB	1 401639
	Anillo cono bronce G 6.2 x 8.5 x 6.2		401540
	Junta brida	NB	1 401640
	Anillo G 21.5 x 26.5 x 3	P	401541
	Arandela A 6 x 10 x 1 A	AL	14 401641
	Cierre bancada trasera	GS	2 400442
3683N004	Bomba de aceite	NB	401642
	Junta bomba alimentación a block	NB	1 410642
36832143	Bomba aceite enfriador	NH	401643
	Junta succióna lubricación aceite	NB	1 410743
36831127	Lubricación aceite a enfriador	NB	1 401644
	Brida recuperador aceite	NB	1 401645
	Brida	NB	1 401646
	Entre múltiples a turbo	AC	1 500546
3684R011	Junta refrigerador aceite	NB	1 401647
	Junta	NB	1 401648
3688A006	Salida de escape turbo	AC	1 350462
0490706	Superior bomba inyectora	NB	1 401566
	Guarnición goma G 21 x 30 x 9	GS	6
	Anillo G 4.5 x 8.5 x 6	GS	2
	Anillo G 6 x 10 x 6	GS	1
	Arandela A 10 x 14 x 1.25 A	AL	2
	Arandela base inyector A 10 x 20 x 2 C	CU	6
	O´ring G 70 x 3	GS	1
	O´ring G 45 x 2.5	GS	1
	O´ring G 44.12 x 2.62	GS	1
	O´ring G 31.34 x 3.53	GS	1
	O´ring G 18.64 x 3.53	GS	1

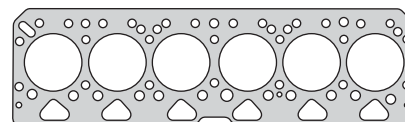

401607

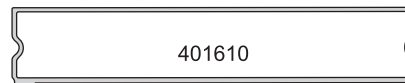

401610

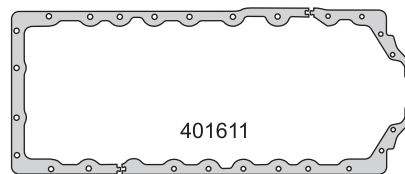

401611

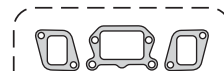

401615

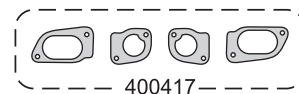

400417

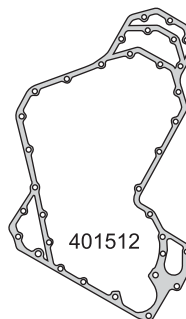

401512

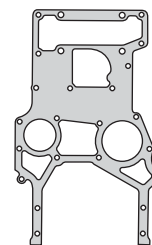

401513

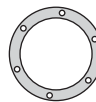

401514



401627



401628

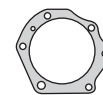

401529

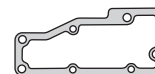

401532

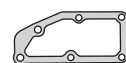

401533



401534



410433



401634



401535

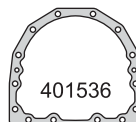

401536



401636



401637



401537



401638



401631



401639



401640



401540



400442



410642



401642



401643



410743



401644



401645



401646



500546



350462

PERKINS



Motor/Engine	Cm³	HP	Ø
6.354-2 Turbo	5798		98.47

Massey Ferguson: 1095/1098/1195/1215 1970/...
Tractores - TD - Estancieros
Grúas - Rodantes



DIESEL

Nº OE	Descripción/Description	Mat.	Ref.
	Jgo. de juntas para motor		401700-R
	Jgo. de juntas superior		401795
36812545	Junta tapa cilindros Ø 104 \pm 1.30	CHA	1 1 400208
36812545	Junta tapa cilindros Ø 104 \pm 1.50	NFT	1 1 400207
	Jgo. tornillos tapa cilindros (HAS19038)		B400200
36811412	Junta tapa válvulas	CG	1 1 400210
36816702	Junta para cárter	NB	1 1 400211
368114124	Distribución a block	NB	1 1 400212
36867139	Tapa bomba de agua	NB	1 1 401714
36867173	Tapa bomba de agua inferior	NB	1 1 410414
	Jgo. múltiple escape (3)	FCH	1 1 401715
	Jgo. múltiple admisión (4)	FCH	1 1 401717
	Salida de escape	FCH	1 1 401718
36867117	Junta placa bomba agua inferior	NB	1 1 401719
36867174	Placa bomba agua	NB	1 1 410419
36847319	Depósito cárter chico	NB	1 1 400233
36866432	Codo bomba de agua	NB	1 1 401733
36816702	Junta para cárter (1.00 mm)	NB	1 1 400234
36816702	Junta para cárter (0.80 mm)	NB	1 1 400235
0490485	Tapa trasera tapa de cilindros	NB	1 1 400036
36817157	Portal retén bancada trasera	NB	1 1 400236
003202	Base filtro aceite cámara	NB	1 1 400237
002794	Base filtro aceite	NB	1 1 400238
36831118	Bomba reguladora a block	NB	1 1 400239
0490687	Tapa trasera termoarranque	CG	1 1 400140
	Jgo. juntas compresor tensa bicil.	VS	1 1 400240
36846408	Inspección botadores	NB	2 1 400242
32811408	Lateral puente a block	GS	4 1 400442
36826107	Tapa inspección engranaje árbol de levas	CG	1 1 400243
	Bomba alimentación combustible	NB	1 1 350943
	Junta turbo entrada turbina	AC	1 1 800343
36866434	Inspección engranaje comando auxiliar	NB	1 1 400244
	Junta salida aceite turbo	NB	1 1 350445
	Vaso combustible	CG	1 1 450045
33828108	Comando bomba combustible	NB	1 1 400246
36832118	Brida caño succión a bomba	NB	1 1 400249
36866426	Acople compresor a block	NB	1 1 400250
36846113	Cuerpo salida agua tapa cilindros	NB	1 1 400254
	Jgo. empaquetadura cigüeñal (2)	SLA	1 1 400158
	Tapa de válvula superior	CG	1 1 400261
	Colector escape turbo	AC	1 1 350462
36862126	Bomba alimentación combustible	NB	1 1 400165
006090	Bomba alimentación combustible	NB	1 1 400465
0490706	Junta bomba inyectora a block	NB	1 1 400066
	Kit de arandelas (57)	VS	1 1 400275
	Jgo. juntas turbo (5)	VS	1 1 800376
36867132	Placa cuerpo múltiple admisión	NB	1 1 400282
36817136	Porta retén bancada trasera	NB	1 1 400283
36822118	Placa adaptador bomba inyección	NB	1 1 400284
	Jgo. juntas turbo (5)	VS	1 1 800376
	Arandela pico inyector A 10 x 19 x 2 C	CU	6 6
	Arandela A 10 x 14 x 1.5 A	AL	15
	Arandela A 13 x 20.5 x 2 A	AL	15

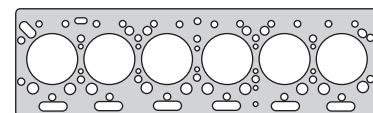

400208



400210

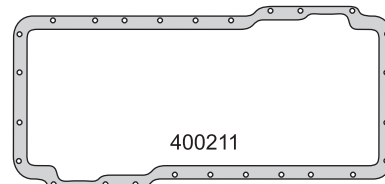

400211

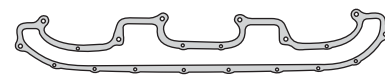

400212

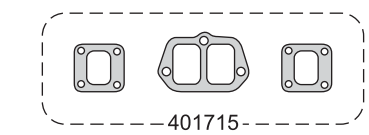

401715

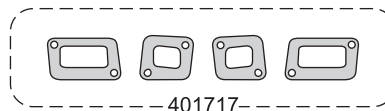

401717

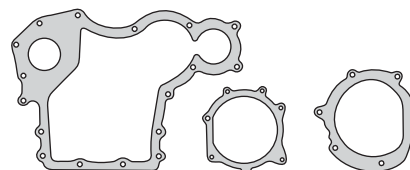

400212

410414

401714

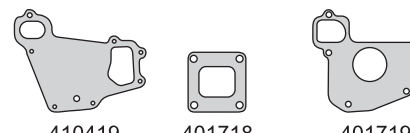

410419

401718

401719



400233

401733

400236

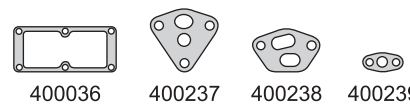

400036

400237

400238

400239

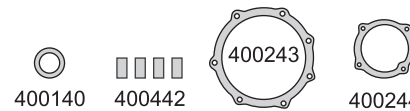

400140

400442

400243

400244

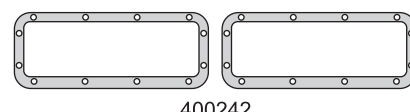

400242



400246

400249

450045

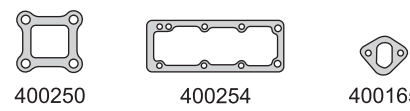

400250

400254

400165

PERKINS

PERKINS



Motor/Engine **6.354-2 Turbo** **5798** **HP** **98.47** **Ø**

Massey Ferguson: 1095/1098/1195/1215 1970/...
Tractores - TD - Estancieros
Grúas - Rodantes



DIESEL

Nº OE	Descripción/Description	Mat.	Ref.
	Arandela A 17 x 22 x 1.5 A	AL	5
105393	Arandela A 19 x 27 x 2 A	AL	1
	Arandela A 8 x 12.5 x 1.5 A	AL	15
	O´ring G 85.32 x 3.53	GS	1
	Kit de retenes completo		R401700
	Jgo. retén válvulas (12)	P	1 R401710P
	Retén bancada 133.35 x 158.75 x 11/13	V	1 R400211V
	Retén distribución 60.32 x 79.36 x 9.5	P	1 R400012P
	Retén auxiliar 22.22 x 35.70 x 9.52	N	R400215N

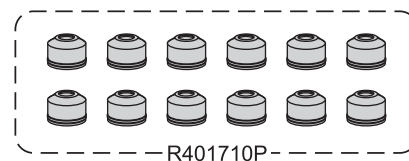
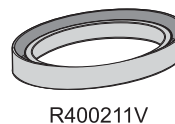
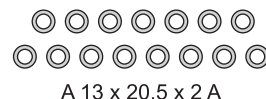
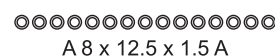
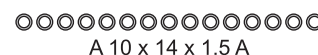
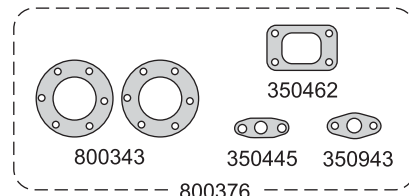
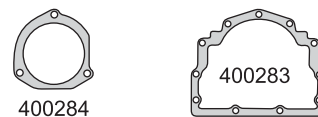
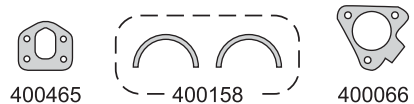

PERKINS

PERKINS



Motor/Engine	Cm³	HP	Ø
4.203 Potenciado	3336	71	91.44

Ford: F100



DIESEL

Nº OE	Descripción/Description	Mat.	Ref.
	Jgo. de juntas para motor		410000-R
36812125	Junta tapa cilindros Ø 92.5 ± 1.40	NFT	1 400007
	Jgo. tornillos tapa cilindros (HAS19038)		B400000
0490704	Conj. junta tapa válvulas superior (4)	CG	1 400010
	Jgo. junta para cárter (4)	NB	1 410011
006072	Tapa distribución	NB	1 400012
36814112	Block caja distribución	NB	1 400013
36866417	Bomba de agua	NB	1 400014
006002	Múltiple escape	FCH	2 400015
006061	Múltiple admisión	NFT	1 400017
0490032	Salida de escape	FCH	1 400018
36883106	Arandela tapa válvulas	GS	3 400130
	Arandela base inyector A 14 x 20 x 1.5 C	CU	400033
33825409	Tapa frontal a tapa inspección	NB	1 400034
0490485	Tapa trasera tapa cilindro	NB	1 400036
006054	Tapa precámara combustión	CU	4 400037
006054	Precámara combustión	AL	410037
33826111	Porta retén bancada trasera	NB	1 400038
36866416	Caja distribución a bomba vacío	NB	1 400039
0490867	Tapa trasera termoarranque	CG	1 400140
36853105	Caja distribución tapa toma fuerza	NB	1 400045
0490685	Comando bomba combustible	NB	1 400146
0490699	Tapa trasera árbol levas	NB	1 400047
0490692	Conexión entrada agua	NB	1 400048
36835411	Conexión salida agua	NB	1 400051
0490024	Salida agua a tapa	NB	1 400052
0490184	Termostato	NB	400053
0490391	Cuerpo codo paso agua	NB	1 400153
006007	Filtro aceite a block	NB	1 400057
36866428	Bomba vacío tapa brida	NB	1 400062
006074	Bomba alimentación combustible	NB	1 400165
36865543	Soporte bomba inyectora	NB	1 400066
003152	Tapa inspección cárter	NB	1 410167
	Kit de arandelas (57)	VS	1 400075
	Arandelas A 10 x 14 x 1 A	AL	15
	Arandelas A 13 x 20 x 1 A	AL	10
	Arandelas A 14.5 x 20.5 x 1.5 C	CU	6
	Arandelas A 17.5 x 22 x 1 A	AL	10
	Arandelas A 19 x 27 x 2 A	AL	1
	Arandelas A 8 x 12.5 x 1 A	AL	15
	Kit de retenes completo		R400000-1
	Jgo. retén válvulas (8)	P	1 R400010P
	Jgo. retén válvulas (8)	P	1 R300310P
	Retén bancada 133.35 x 158.75 x 11/13	V	1 R400211V
	Retén distribución 60.32 x 79.36 x 9.5	P	1 R400012P

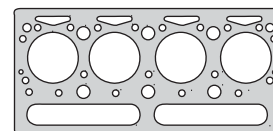

400007

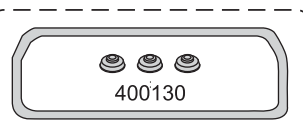

400130

400010

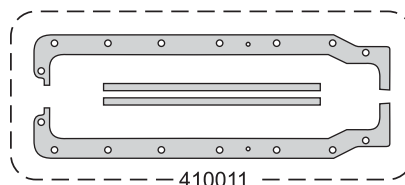

410011

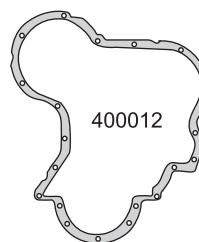

400012

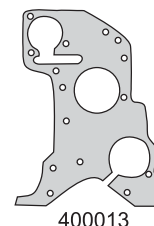

400013



400014



400015



400018



400017



400033



400034

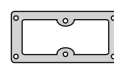

400036

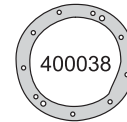

400038

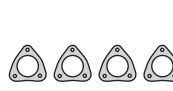

400037



400039



400140



400045



400146



400048



400047



400051

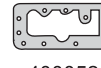

400052



400153



400057



400062



400165



400066



400167



R400211V



R400012P



R300310P



R400010P

PERKINS

PERKINS



Motor/Engine	Cm³	HP	Ø
6PF - 305 Potenciado	5004	100	91.49

Ford: F600



DIESEL

Nº OE	Descripción/Description	Mat.	Ref.
	Jgo. de juntas para motor		410100-R
006063	Junta tapa cilindros Ø 92.5 ± 1.40	NFT 1	400307
	Junta tapa cilindros Ø 92.5 ± 1.25	FCH	400308
	Jgo. tornillos tapa cilindros (HAS19038)		B400300
0490760	Conj. junta tapa válvulas superior (5)	CG 1	400110
006074	Jgo. junta para cárter (4)	NB 1	410111
006072	Caja distribución tapa frontal	NB 1	400012
36814112	Block caja distribución	NB 1	400013
36866417	Bomba de agua placa trasera	NB 1	400014
006002	Múltiple escape	FCH 3	400015
0490026	Jgo. múltiple admisión (2)	NFT 1	400117
0490032	Salida de escape	FCH 1	400018
	Arandela tapa válvulas	GS 4	400130
0920113	Arandela base inyector A 14 x 20 x 1.5 C	CU	400033
33825409	Tapa frontal tubo venteo	NB 1	400034
0490458	Tapa trasera tapa cilindros	NB 1	400036
006054	Precámara combustión	CU 6	400037
006054	Precámara combustión	AL	410037
33826111	Porta retén bancada trasera	NB 1	400038
36866416	Caja distribución bomba vacío	NB 1	400039
	Junta tapa trasera termoarranque	CG 1	400140
36853105	Caja distribución tapa t/fuerza	NB 1	400045
0490685	Comando bomba combustible	NB 1	400146
0490699	Block tapa trasera	NB 1	400047
0490692	Conexión entrada agua	NB 1	400048
002742	Caño aceite a block	NB 1	400249
36835411	Conexión salida agua	NB 1	400051
0490024	Salida agua a tapa	NB 1	400052
0490184	Termostato	NB	410053
0490351	Cuerpo codo paso agua	NB 2	400153
006007	Filtro aceite a block	NB 1	400057
36866428	Bomba vacío a tapa distribución	NB 1	400062
006074	Bomba vacío a bomba combustible	NB 1	400165
36865543	Soporte bomba inyectora	NB 1	400066
	Kit arandelas (57)	VS 1	400175
	Arandelas A 14 x 20 x 1.25 C	CU 6	
	Arandelas A 10 x 14 x 1 A	AL 15	
	Arandelas A 13 x 20 x 1.25 A	AL 10	
	Arandelas A 17 x 22 x 1 A	AL 10	
	Arandelas A 19 x 27 x 2 A	AL 1	
	Arandelas A 8 x 12 x 1 A	AL 15	
	Kit de retenes completo		R410100
	Jgo. retén válvulas (12)	P 1	R400110P
	Jgo. retén válvulas (12)	P 1	R540210P
	Retén bancada 133.35 x 158.75 x 11/13	P 1	R400211V
	Retén distribución 60.32 x 79.36 x 9.5	V 1	R400012P

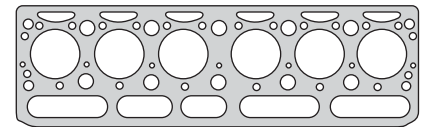

400307

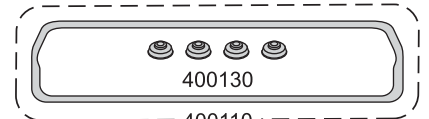

400130

400110

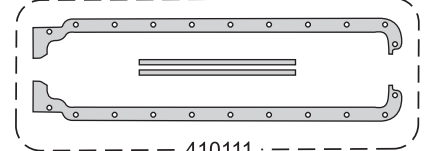

410111

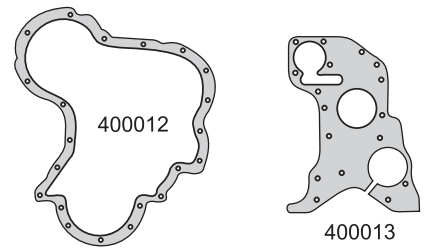

400012

400013



400015

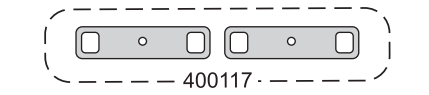

400117

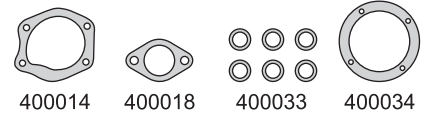

400014

400018

400033

400034

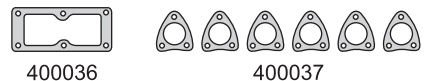

400036

400037

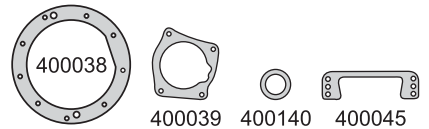

400038

400039

400140

400045

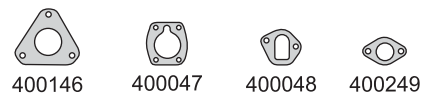

400146

400047

400048

400249

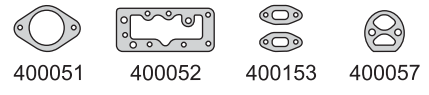

400051

400052

400153

400057



400062

400066

400165

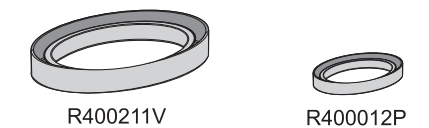

R400211V

R400012P



R540210P

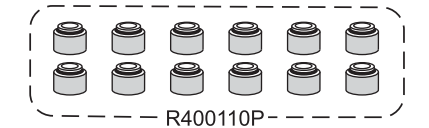

R400110P

PERKINS

PERKINS



Motor/Engine	Cm³	HP	Ø
P3 - 152	2502	42	91.44

Perkins: Tractor
Massey Ferguson: MF50 Tractor - MF50X/55X
 MF135/200/235/250



DIESEL

Nº OE	Descripción/Description	Mat.	Ref.
	Jgo. de juntas para motor		410200-R
368112122	Junta tapa cilindros Ø 93 ± 1.45	FCH 1	400508
	Jgo. tornillos tapa cilindros (HAS19038)		B400000
0490491	Conj. junta tapa válvulas superior (3)	CG 1	400510
003249	Jgo. junta para cárter (4)	NB 1	400511
	Tapa distribución	NB 1	410212
36814119	Placa distribución	NB 1	400513
36866417	Bomba de agua	NB 1	400014
006002	Múltiple escape	FCH 2	400015
0490032	Salida de escape	FCH 1	400018
	Arandela tapa válvulas	GS 2	400130
	Arandela pico inyector A 14 x 20 x 1.5 C	CU	400033
	Depósito cárter	NB 1	400533
0490482	Cuerpo salida agua	NB 1	400534
85014018	Bomba hidráulica a toma fuerza	CB 1	400535
006081	Tapa trasera cigüeñal	NB 1	400035
0490485	Tapa trasera tapa cilindros	NB 1	400036
0490738	Cuerpo salida agua tapa cilindros	NB 1	400536
006054	Precámara combustible	CU 3	400037
36862511	Tapa trasera árbol levas	NB 1	400537
006054	Precámara combustión	AL	410037
	Base filtro aceite c/ref.	NB 1	400237
0490686	Cuerpo toma aire	NB 2	400538
0490486	Tapa conexión entrada aire	NB 1	400539
0490687	Tapa trasera termoarranque	CG 1	400140
36862512	Tapa inspección carga aceite	NB 1	400540
36862165	Bomba alimentación	NB 1	400541
002478	Tapa inspección engranje distribución	NB 1	400542
36853105	Caja a tapa toma fuerza	NB 1	400045
0490685	Comando bomba combustible	NB 1	400146
36835411	Conexión salida agua	NB 1	400051
0490391	Cuerpo codo paso agua	NB 1	400153
006047	Filtro aceite a block	NB 1	400057
36883106	Jgo. juntas bancada cigüeñal (2)	SLA 1	400158
36851106	Soporte bomba vacío	NB 1	400163
006074	Bomba alimentación combustible	NB 1	400165
	Kit de retenes completo		R400500
	Jgo. retén válvulas (6)	P 1	R400010P
	Jgo. retén válvulas (6)	P 1	R400510P
	Retén bancada 133.35 x 158.75 x 11/13	P 1	R400211P
	Retén distribución 60.32 x 79.36 x 9.5	P 1	R400012P

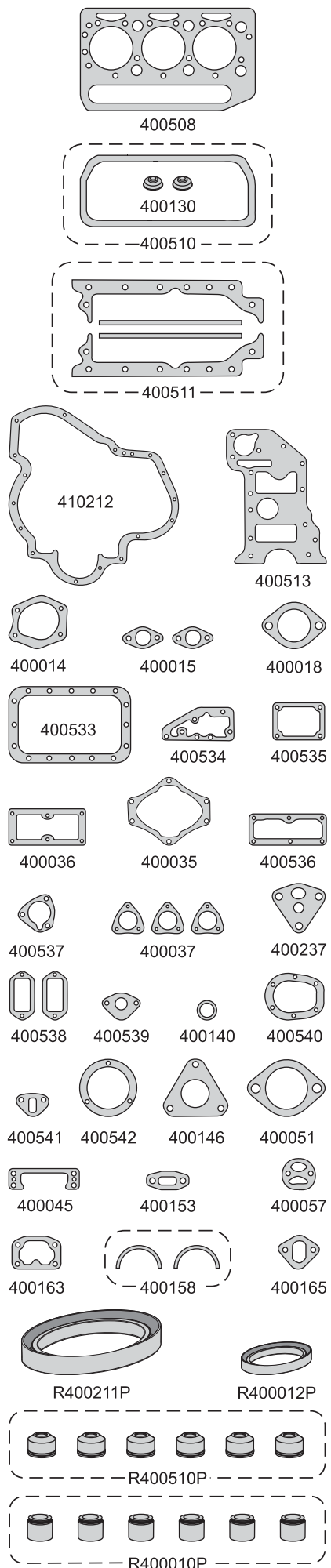

PERKINS

PERKINS



Motor/Engine	Cm³	HP	Ø
MF265 Potenciado	3336	71	91.44

Massey Ferguson: Potenciado



DIESEL

Nº OE	Descripción/Description	Mat.	Ref.
	Jgo. de juntas para motor		410300-R
36812125	Junta tapa cilindros Ø 92.5 ± 1.40	NFT	400005
	Junta tapa cilindros Ø 92.5 ± 1.40	NFT 1	400007
	Junta tapa cilindros Ø 92.5 ± 1.15	CNC	400008
	Jgo. tornillos tapa cilindros (HAS19038)		B400000
0490704	Conj. junta tapa válvulas superior (4)	CG 1	400010
	Jgo. junta para cárter (4)	NB 1	410311
006013	Tapa distribución	NB 1	400612
36814112	Block caja distribución	NB 1	400013
36866417	Bomba de agua	NB 1	400014
006002	Múltiple escape	FCH 2	400015
006061	Múltiple admisión	NFT 1	400017
0490032	Salida de escape	FCH 1	400018
	Arandela tapa válvulas	GS 3	400130
006020	Brida bomba hidráulica	NB 1	400631
0920113	Arandela base inyector A 14 x 20 x 1.5 C	CU 4	400033
33825409	Tapa frontal a tapa inspección	NB 1	400034
0490485	Tapa trasera tapa cilindros	NB 1	400036
006054	Tapa precámara combustión	CU 4	400037
006054	Precámara combustión	AL	410037
33826111	Porta retén bancada trasera	NB 1	400038
	Tapa trasera termoarranque	CG 1	400140
0490685	Comando bomba combustible	NB 1	400146
0490699	Tapa trasera árbol levas	NB 1	400047
0490692	Conexión entrada agua	NB 1	400048
36835411	Conexión salida agua	NB 1	400051
0490024	Salida agua a tapa	NB 1	400052
0490184	Termostato	NB	400053
0490391	Cuerpo codo paso agua	NB 1	400153
006007	Filtro aceite a block	NB 1	400057
006074	Bomba alimentación combustible	NB 1	400165
36865543	Soporte bomba inyectora	NB 1	400066
	O'ring G 18.77 x 1.78	GS 2	400767
	Kit arandelas (57)	VS	400075
	Arandela A 8 x 12.5 x 1 A	AL	
	Arandela A 10 x 14 x 1 A	AL	
	Arandela A 13 x 20 x 1 A	AL	
	Arandela A 17.5 x 22 x 1 A	AL	
	Arandela A 14.5 x 20.5 x 1.5 C	CU	
	Arandela A 19 x 27 x 2 A	AL	
	Kit de retenes completo		R400000-1
	Jgo. retén válvulas (8)	P 1	R400010P
	Jgo. retén válvulas (8)	P 1	R300310P
	Retén bancada 133.35 x 158.75 x 11/13	P 1	R400211V
	Retén distribución 60.32 x 79.36 x 9.5	V 1	R400012P

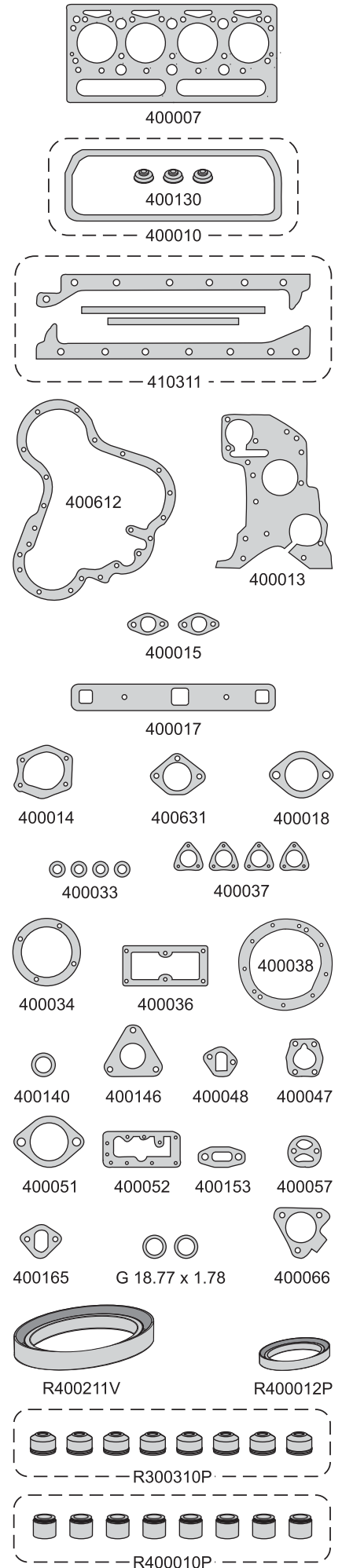

PERKINS

PERKINS



Motor/Engine	Cm³	HP	Ø
T6.354-4	5798	172	98.63

Perkins: Tractor 1215 - 1218



DIESEL

Nº OE	Descripción/Description	Mat.	Ref.
105784	Jgo. de juntas para motor		410400-R
	Junta tapa cilindros Ø 104 \pm 1.50	NFT	400407
368142607	Junta tapa cilindros Ø 104 \pm 1.45	CHA	400408
	Jgo. tornillos tapa cilindros (HAS19038)		B400200
006104	Conj. junta tapa válvulas (5)	CG	400410
006088	Junta para cárter	NB	400211
36814124	Caja distribución a block	NB	400212
36867173	Bomba de agua a block	NB	410414
	Jgo. múltiple escape (3)	AC	400416
	Jgo. múltiple admisión (4)	AC	400417
37481108	Salida de escape	AC	400418
36867174	Placa bomba de agua	NB	410419
36865532	Bomba de aceite a block	NB	400427
36833125	Bomba carga de aceite	CG	400429
36831122	Válvula reguladora aceite	NB	400430
36832133	Caño aceite turbo	NB	400431
36833148	Drenaje aceite turbo	NB	400432
36861448	Adaptador alimentación aceite	NB	400433
36862538	Base filtro aceite	NB	410433
36861745	Conexión salida agua	NB	400434
36834143	Bomba inyectora	NB	400435
0490485	Tapa trasera tapa cilindros	NB	400036
36817157	Porta retén trasero	NB	400236
36866739	Cabezal a block	NB	410437
36823132	Tapa múltiple codo a múltiple admisión	NB	400438
36821118	Entrada agua a block	NB	400439
0490474	Caño ventilación a tapa válvulas	NB	400440
0490053	Tapa cierre	NB	400441
32811408	Lateral puente a block	GS	400442
36826107	Tapa inspección engranaje árbol de levas	CG	400243
36866434	Tapa inspección engranaje codo auxiliar	NB	400244
36833139	Caño bomba de aceite	NB	400444
	Arandela tapa válvulas	GS	400446
36866426	Compresor a block	NB	400250
36846113	Cuerpo salida a agua	NB	400254
006090	Bomba alimentación a block	NB	400465
36822118	Placa adaptador a block	NB	400284
	Arandela inyector A 10 x 20 x 1 C	CU	6
	Arandelas A 7 x 10 x 1 A	AL	12
	Kit de retenes completo		R400200-1
	Jgo. retén válvulas (12)	P	R400210P
	Retén bancada 133.35 x 158.75 x 11/13	P	R400211P
	Retén distribución 60.32 x 79.36 x 9.5	P	R400012P
	Retén auxiliar 22.22 x 35.70 x 9.52	N	R400215N

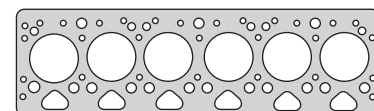

400408

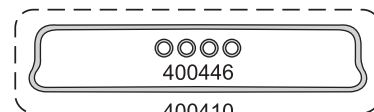

400446

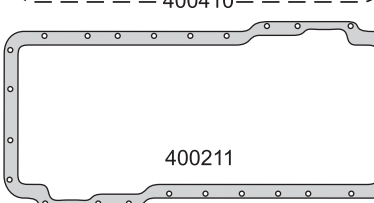

400410

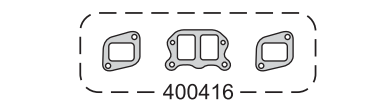

400211



400416

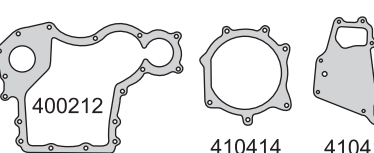

400212

410414

410419

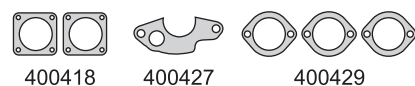

400418

400427

400429



400430

400431

400432

410433



400433

400434

400236

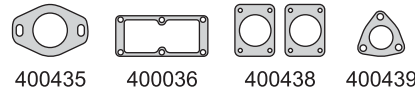

400435

400036

400438

400439

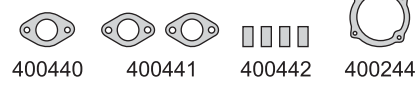

400440

400441

400442

400244



400243

400444

400254



400465

400250

400284

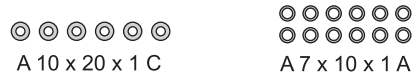

A 10 x 20 x 1 C

A 7 x 10 x 1 A

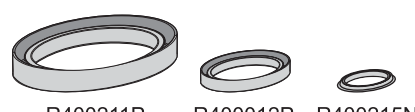

R400211P

R400012P

R400215N



R400210P

PERKINS

PERKINS



Motor/Engine	Cm³	HP	Ø
D4.203/AD4.203 Iny. Directa	3330	71	91.4

Massey Ferguson: Tractor MF65X - MF40B/65
MF155/158/165/260/155
MF164C - CBC1000



DIESEL

Nº OE	Descripción/Description	Mat.	Ref.
420311/309	Jgo. de juntas para motor		410500-R
	Junta tapa cilindros Ø 93 ± 1.40	NFT	410505
70490147	Junta tapa cilindros Ø 93 ± 1.40	NFT	1 410507
	Junta tapa cilindros Ø 93 ± 1.50	CNC	410508
36811112	Junta tapa válvulas	CG	1 410510
36884108	Jgo. junta para cárter (4)	NB	1 410511
70490031	Tapa distribución	NB	1 410512
70490030	Placa distribución	NB	1 410513
36866415	Tapa bomba de agua	NB	1 410514
36837409	Múltiple escape	NFT	2 410516
36867116	Múltiple admisión	NB	1 410517
80490032	Salida de escape	NFT	1 410518
70920081	Arandela inyector A 10 x 20 x 1.5 A	AL	410533
33817114	Arandela A 10 x 21 x 2 C	CU	410534
0490485	Tapa trasera tapa cilindro	NB	1 400036
70490014	Tubo salida de escape	NFT	1 410538
36817141	Superior	NB	1 410539
36812512	Tapa inspección delantera	NB	1 400540
70490063	Alojamiento bomba inyectora	NB	1 410546
0490699	Alojamiento comando	NB	1 400047
0490697	Tapa alojamiento engranaje	NB	2 410547
0490692	Entrada agua a block	NB	1 400048
36865108	Inspección caja distribución	NB	1 410548
0490702	Desvió lateral agua	NB	1 410549
0490707	Conexión superior bomba agua	NB	1 410551
0490701	Salida agua tapa cilindro	NB	1 400052
2415745	O'ring G 91.44 x 5.33	GS	1 410552
064144	O'ring G 21.82 x 3.53	GS	1 410553
0490514	Filtro aceite a block	NB	2 410557
	Jgo. empaquetadura cigüeñal (2)	SNA	410958
36812152	Soporte tapa alimentación	NB	1 400165
0490706	Soporte bomba inyectora	NB	1 410566
	Arandela A 14 x 20 x 1.5 C	CU	4
	Arandela A 10 x 20 x 2 C	CU	4
	Kit de retenes completo		R400000-1
	Jgo. retén válvulas (8)	P	1 R400010P
	Jgo. retén válvulas (8)	P	1 R300310P
	Retén bancada 133.35 x 158.75 x 11/13	P	1 R400211P
	Retén distribución 60.32 x 79.36 x 9.5	P	1 R400012P

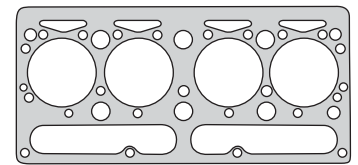

410507



410510

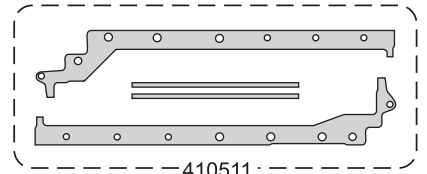

410511



410516

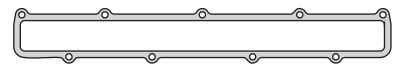

410517

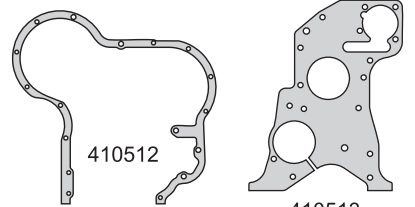

410512

410513



410514



410518

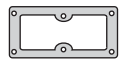

400036

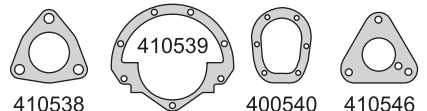

410538

410539

400540

410546



400047



410547



400048



410549



410548



410551



400052



410557



400165



410566



410958



R400211P



R400012P

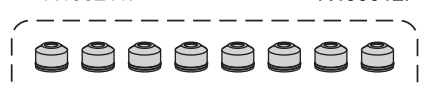

R300310P

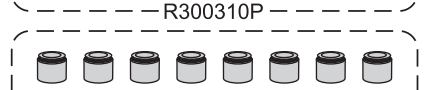

R400010P

PERKINS



Motor/Engine	Cm³	HP	Ø
Q20B4 - 4.236 4.248	3860 4070	70 70	98.4 101

GM Chevrolet: GM D10/20/40 Aspirado Turbo
Massey Ferguson: MF220 - F290 - MF85X
Maxion-Perkins: GM D10 - F350 - VW 6.80 Case 550



DIESEL

Nº OE	Descripción/Description	Mat.	Ref.
424801/423607	Jgo. de juntas para motor		410600-R
	Jgo. de juntas superior		410695
	Jta. tapa cilindros Ø 104 ±1.70	NFT	410605
36812338	Jta. tapa cilindros Ø 104 ±1.70	NFT	410607
70490149	Junta tapa válvulas	CG	410610
36815706	Junta para cárter	NB	410611
36813138	Tapa distribución	NB	410612
36814127	Placa distribución	NB	410613
36866724	Tapa bomba de agua trasera	NB	410614
36862134	Múltiple escape	FCH	410616
0490301	Salida de escape	FCH	400218
70490144	Bomba de agua a block	NB	410619
36866416	Adaptador bomba de vacío	NB	410630
70490146	Block a bomba de agua	NB	410631
36853514	Cuerpo salida agua	NB	410632
0921173	Arandela pico inyector A 10 x 20 x 1.5 C	CU	410533
36851409	Tapa trasera tapa cilindros	NB	410633
36862517	Filtro lubricación block y placa	NB	410634
36834143	Bomba inyectora	NB	400435
0490734	Carcasa termostato	NB	410635
36817157	Porta retén bancada trasera	NB	400236
36862133	Múltiple admisión central	NB	410636
36862151	Conexión superior salida de agua	NB	410637
002794	Base filtro aceite	NB	400238
36862131	Múltiple admisión trasera	NB	410638
36865511	Distribución a bomba de vacío	NB	400039
36866462	Múltiple admisión frontal	NB	410639
7049145	Cuerpo delantero y trasero bomba de agua	NB	410640
36835425	Carcasa a conexión superior	CG	410641
32811113	Bastón placa interior a block	GS	400442
36851113	Bomba alimentación a block	NB	410642
36832122	Tubo succión bomba aceite	NB	410643
	Junta succión a lubricación aceite	NB	410743
36825107	Cierre inspección distribución	NB	400244
0490355	Tubo succión a válvula alimentación	NB	410644
	Junta boca lubricación	NB	410744
36822111	Colector escape	NFT	410645
0490773	Comando bomba inyectora	NB	400146
70490100	Acoplamiento bomba inyectora	NB	410546
	Adaptador vacío	NB	410747
	Bomba de vacío a brida	NB	400062
36817136	Porta retén bancada trasera	NB	400283
36866416	Anillo lubricación tapa cilindros G 7.2 x 11 x 6	GS	
	Arandela A 10 x 20 x 2 C	CU	
	Kit de retenes completo		R410600
	Jgo. retén válvulas (8)	P	R300310P
	Jgo. retén válvulas (8)	P	R400210P
	Retén bancada 133.35 x 158.75 x 11/13	P	R400211P
	Retén distribución 60.32 x 79.36 x 9.5	P	R400012P

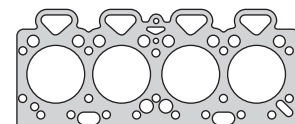

410607

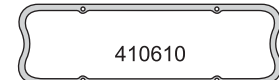

410610

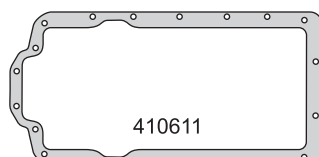

410611



410616

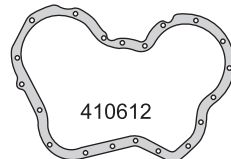

410612



410613



410614



410619



400218



410630

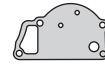

410631

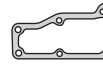

410632



410533

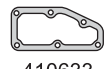

410633



410634



400435



410635

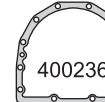

400236



410636



410637



400238



410638



400039



410639



410640



410641



410642



400442



410643



410743



410744



410644



400244



400146



410645



410546



410747



400062

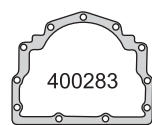

400283



R400211P



R400012P

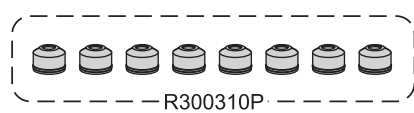

R300310P

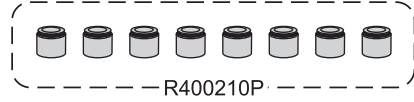

R400210P

PERKINS

PERKINS



Motor/Engine	Cm³	HP	Ø
A4 - 248	4070	75	100

Massey Ferguson: Agrícola - Case 580H - MF85
270 - 275 - 285 - 290
MF 220/220A - Hyster H110



DIESEL

Nº OE	Descripción/Description	Mat.	Ref.
424801/802	Jgo. de juntas para motor		410700-R
	Junta tapa cilindros Ø 104 ± 1.70	NFT 1	410605
36812338	Junta tapa cilindros Ø 104 ± 1.70	NFT	410607
70490149	Junta tapa válvulas	CG 1	410610
36815707	Junta para cárter	NB 1	401511
36813137	Tapa distribución	NB 1	410712
36814127	Placa distribución	NB 1	410613
36866724	Cuerpo bomba de agua	NB 1	410614
36862134	Múltiple escape	FCH 2	410616
0490301	Salida de escape	FCH 1	400218
70490144	Bomba de agua a block	NB 1	410719
36866416	Adaptador bomba vacío	NB 1	410630
36867156	Bomba agua a block	NB 1	410731
36853514	Cuerpo salida agua	NB 1	410632
0921173	Arandela pico inyector A 10 x 20 x 2 C	CU 4	410533
36851409	Tapa trasera tapa cilindros	NB 1	410633
36862517	Filtro lubricación a block	NB 2	410634
36834143	Adaptador bomba inyectora	NB 1	400435
0490734	Carcasa termostato	NB 1	410635
	Porta retén bancada trasera	NB 1	400236
36862133	Múltiple admisión central	NB 1	410636
36862151	Conexión superior salida agua	NB 1	410637
36862131	Múltiple admisión trasera	NB 1	410638
36865511	Distribución a bomba vacío	NB 1	400039
36866462	Múltiple admisión frontal	NB	410639
70490145	Cuerpo delantero y trasero bomba agua	NB 1	410640
36835428	Carcasa a conexión superior	CG 1	410641
	Bastón placa a block	GS 2	400442
36851113	Bomba alimentación a block	NB 1	410642
	Tubo succión bomba aceite	NB 1	410643
36832404	Bomba succión a lubricación aceite	NB 1	410743
0490355	Bomba succión a válvula alivio	NB 1	410644
36862138	Boca lubricación	NB 2	410744
36822111	Colector escape	NFT 2	410645
36866722	Trasera bomba	NB 1	410745
0490773	Comando bomba inyectora	NB 1	400146
33825414	Cubierta tapa trasera	CG 1	410746
7049083	Acople bomba inyectora	NB 1	410546
	Adaptador vacío	NB 1	410747
	Jgo. empaquetadura bancada cigüeñal (2)	SLA 1	400158
	Jgo. empaquetadura bancada cigüeñal	SNA	410958
36866428	Bomba vacío a brida	NB 1	400062
36817137	Carcasa a block	NB 1	400283
	Anillo lubricación tapa de cilindros G 7.2 x 11 x 6	GS 1	
	Kit de retenes completo		R410700
	Jgo. retén válvulas (8)	P 1	R300310P
	Jgo. retén válvulas (8)	P 1	R400210P
	Retén bancada 133.35 x 158.75 x 11/13	V 1	R400211V
	Retén distribución 60.32 x 79.36 x 9.5	P 1	R400012P

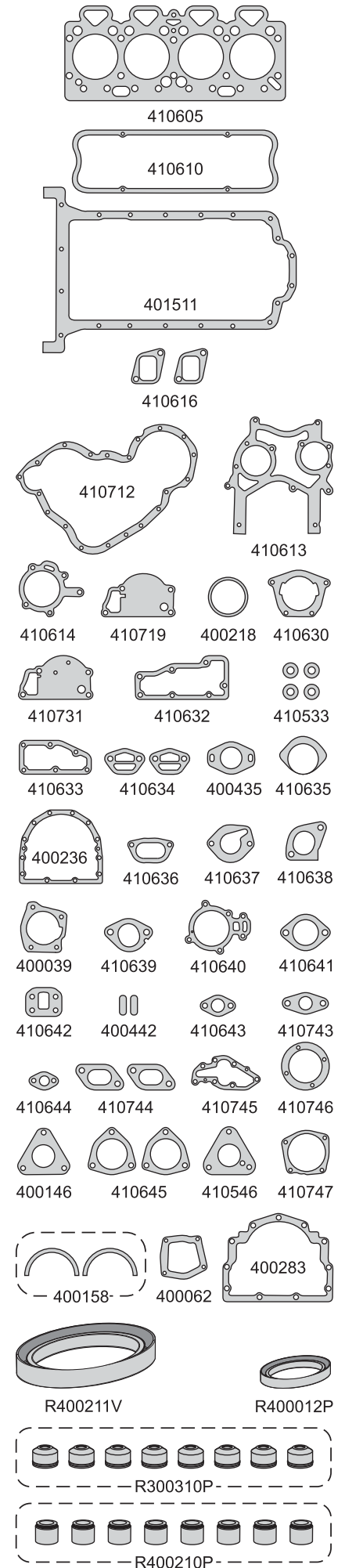

PERKINS

PERKINS



Motor/Engine	Cm³	HP	Ø
T 4.33 Turbo Iny. Directa	3330	91/95	91.46

Perkins: Pick Up - Camiones livianos



DIESEL

Nº OE	Descripción/Description	Mat.	Ref.
005967	Jgo. de juntas para motor	●	410800-R
006283	Junta tapa cilindros Ø 93 \pm 1.40	NFT	410807
	Junta tapa cilindros Ø 93 \pm 1.25	CNC	1 410808
0490704	Conj. junta tapa válvulas (4)	CG	1 400010
006076	Jgo. junta para cárter (4)	NB	1 410011
006072	Tapa distribución	NB	1 400012
36814112	Placa distribución	NB	1 400013
36866417	Tapa bomba de agua	NB	1 400014
006322	Múltiple escape	NFT	2 410816
006061	Múltiple admisión	NFT	1 400017
0490184	Conexión salida agua	CB	1 300019
	Arandelas tapa válvula	GS	3 400130
36833148	Drenaje aceite turbo	NB	1 400432
33825409	Tapa frontal	NB	1 400034
3686454	Turbo a descarga caño aceite	NB	1 410834
36832131	Entrada aceite turbo	NB	1 410835
0490485	Tapa trasera	NB	1 400036
006319	Múltiple admisión a codo admisión	NB	1 410836
006320	Turbo a codo salida de escape	NFT	1 410837
338261111	Porta retén bancada	NB	1 400038
36866416	Caja distribución bomba vacío	NB	1 400039
36822111	Codo a salida de escape	NFT	1 410645
006323	Comando bomba combustible	NB	1 400246
0490699	Tapa trasera árbol levas	NB	1 400047
0490692	Conexión entrada agua	NB	1 400048
3683211	Succión aceite	NB	1 400249
0490024	Salida agua a tapa cilindros	NB	1 400052
006007	Filtro aceite a block	NB	1 400057
36885008	Turbo a múltiple escape	AC	1 350462
006074	Bomba alimentación	NB	1 400165
L 311 FF 02	Arandela inyector A 15.1 x 18 x 1.5 C	CU	4
	Kit de retenes completo		R400000-1
	Jgo. retén válvulas (8)	P	1 R400010P
	Jgo. retén válvulas (8)	P	1 R300310P
	Retén bancada 133.35 x 158.75 x 11/13	P	1 R400211P
	Retén distribución 60.32 x 79.36 x 9.5	P	1 R400012P

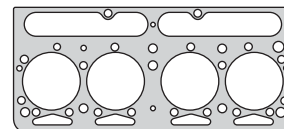

410808

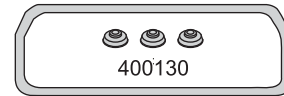

400130

400010

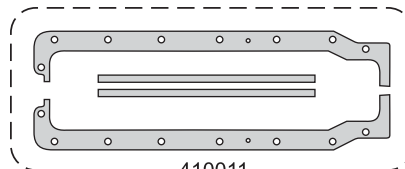

410011

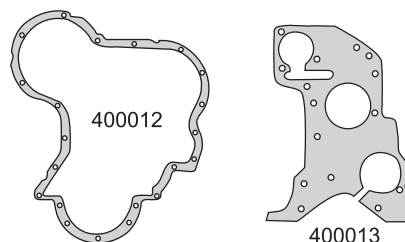

400012

400013

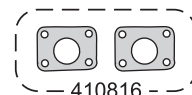

410816



400017

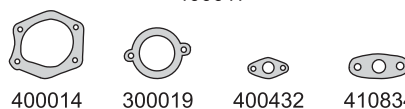

400014

300019

400432

410834

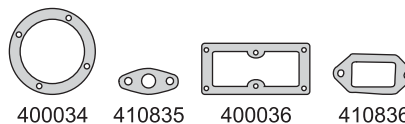

400034

410835

400036

410836

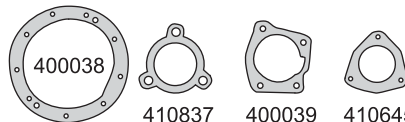

400038

410837

400039

410645

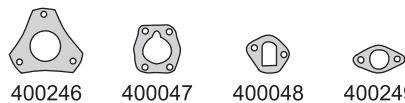

400246

400047

400048

400249

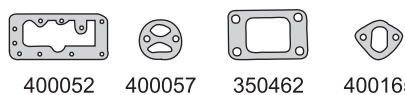

400052

400057

350462

400165



R400211P



R400012P



R300310P



R400010P

PERKINS



Motor/Engine	Cm³	HP	Ø
6-357 Vehicular	5840	120	104.1
6-357 Agrícola	5840	91	104.1
6-357 Industrial	5840	108	104.1

Chevrolet: Brasil D60 - D70
Chrysler: P700D - P900
Ford: F600/750/1100 - MF3366 - F6000
 F7500/11000



DIESEL

Nº OE	Descripción/Description	Mat.	Ref.
635752/704	Jgo. de juntas para motor		410900-R
	Jgo. de juntas superior		410995
70490058	Junta tapa cilindros Ø 107 ± 1.50	NFT	1 1 410907
70490139	Junta tapa válvulas	CG	1 1 410910
70490132	Junta para cárter	CG	410911
70490132	Junta cárter versión agrícola	NB	1 420011
70490092	Tapa distribución	NB	1 410912
70490065	Inspección distribución	CG	2 410913
70490050	Tapa bomba de agua	NB	1 410914
0490675	Jgo. múltiple escape (3)	NFT	1 1 410916
70490087	Múltiple admisión	NB	1 1 410917
	Salida de escape	NB	1 1 400218
70490020	Tubo salida de escape	NFT	1 1 410918
70490071	Conexión salida agua	NB	1 1 410919
70490112	Placa adaptadora bomba alimentación	NB	1 410928
70490024	Accionamiento taquímetro	NB	1 410929
704900833	Adaptador distribución	NB	1 410630
70490136	Placa adaptadora bomba	NB	1 410930
70490135	Bomba alimentación a block	NB	2 410931
70490143	Filtro aceite	NB	2 410932
70490049	Succión bomba aceite	NB	2 410933
70490091	Succión bomba aceite	NB	1 410934
0490263	Porta retén trasero	NB	1 410936
70490101	Cámara de agua	NB	2 410937
0490300	Cámara de agua tapa cilindros	NB	1 1 410938
0490676	Carcasa termostato	NB	1 1 410939
0490307	Entrada admisión	NB	1 1 410941
70490093	Conexión superior salida agua	NB	1 1 410942
0490736	Entrada agua a block	NB	1 410943
0490288	Placa a block	NB	1 410944
049025	Tubo succión a block	NB	1 410945
70490100	Acople bomba inyectora	NB	1 410546
0490433	Tubo salida escape	NFT	1 1 410946
	Jgo. empaquetadura a cigüeñal (2)	SLA	1 400158
70730006	Jgo. empaquetadura a cigüeñal	SNA	410958
	Arandela A 10 x 16 x 1 C	CU	6
0921176	Arandela A 8 x 12 x 1 A	AL	7
	Arandela A 8 x 12 x 1 C	CU	6
0920113	Arandela A 14 x 20 x 1.5 C	CU	14
	Arandela A 14 x 20 x 1 C	CU	
	Arandela A 10 x 16 x 1 A	AL	8
	Arandela A 40 x 47 x 1 C	CU	
	Jgo. retén válvulas (12)	N	1 R410910N
	Retén distribución 50.9 x 69.8 x 9.5	N	1 R410912N

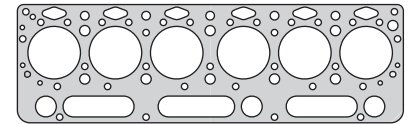

410907

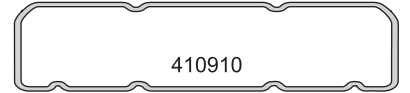

410910

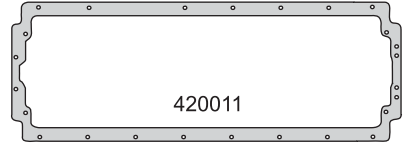

420011

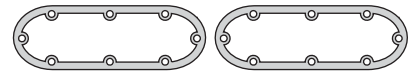

410937



410917

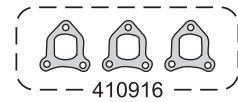

410916

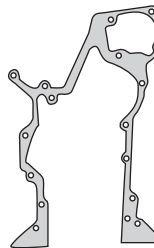

410912



410914

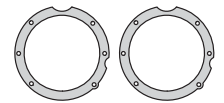

410913

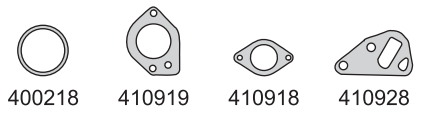

400218



410919



410918



410928



410929



410630



410931

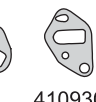

410930



410933



410932



410934

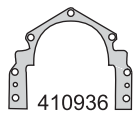

410936

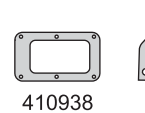

410938

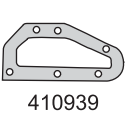

410939



410941



410942



410943



410944



410945



410546



410946



400158



R410912N

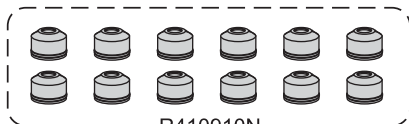

R410910N

PERKINS

PERKINS



Motor/Engine	Cm³	HP	Ø
6-357 Vehicular	5840	120	104.1
6-357 Agrícola	5840	91	104.1
6-357 Industrial	5840	108	104.1

Ford: F400/600/7000/11000/12000/13000
M. Ferguson: MF 400C



DIESEL

Nº OE	Descripción/Description	Mat.	Ref.
635801/802	Jgo. de juntas para motor		420000-R
	Jgo. de juntas superior		420095
3681601	Junta tapa cilindros Ø 109 \pm 1.50	NFT	1 1 420007
70490096	Junta tapa válvulas	CG	1 1 420010
	Junta para cárter versión agrícola	NB	1 1 420011
70490132	Junta para cárter	CG	1 1 410911
70490097	Tapa distribución	NB	1 1 420012
70490065	Inspección distribución	CG	2 2 410913
70490050	Tapa bomba de agua	NB	1 1 410914
	Jgo. múltiple escape (3)	NFT	1 1 420016
70490024	Accionamiento taquímetro	NB	1 1 410929
70490136	Placa adaptador bomba a block	NB	1 1 410930
	Adaptador	NB	1 1 410630
70490129	Bomba adaptador a block	NB	2 2 410931
70490143	Filtro aceite a block	NB	1 1 410932
70490049	Succión bomba aceite	NB	2 2 410933
70490091	Succión bomba aceite	NB	1 1 410934
70490128	Porta retén trasero	NB	1 1 420036
70490069	Respirador adaptador	NB	1 1 420037
70490116	Tapa carcasa termostato	NB	1 1 420038
70490083	Adaptador inspección a distribución	NB	1 1 420039
70490119	Conexión superior a carcasa	NB	1 1 420041
0490307	Colector admision filtro aire	NB	1 1 410941
7049114	Tapa trasera a tapa cilindros	NB	1 1 420042
7049118	Colector admisión central	NB	2 2 420043
0490736	Entrada agua a block	NB	1 1 410943
70490117	Colector	NB	2 2 420044
0490288	Placa a block	NB	1 1 410944
70490115	Lateral bomba de agua	NB	2 2 420045
0490275	Tubo a block	NB	1 1 410945
70490026	Tapa comando taquímetro	NB	1 1 420046
70490100	Acople bomba inyectora	NB	1 1 410546
0490433	Tubo salida de escape	NFT	1 1 410946
	Tubo acople	NFT	1 1 420047
	Arandela A 10 x 21 x 2 C	CU	6
	Arandela pico inyector A 10 x 20 x 2 C	CU	6
	Arandela A 14 x 20 x 1.5 C	CU	6
	Arandela A 41.3 x 45 x 1 C	CU	6
	Kit de retenes completo		R420000
	Jgo. retén válvulas (12)	P	1 1 R540210P
	Retén bancada 133.35 x 158.75 x 11/13	P	1 R400211P
	Retén distribución 60.32 x 79.36 x 9.5	P	1 R400012P

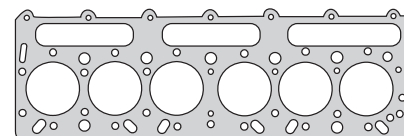

420007



420010

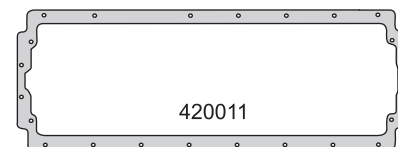

420011

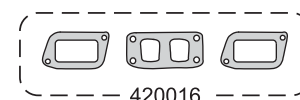

420012

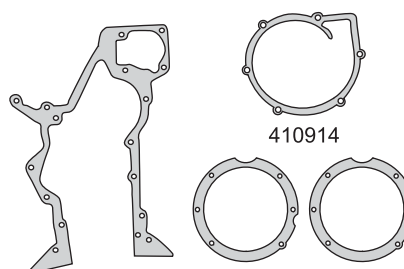

410914



410913

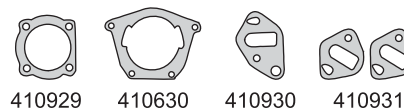

410929

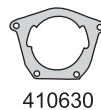

410630

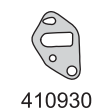

410930



410931

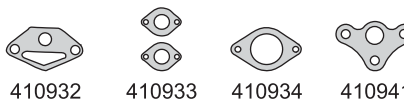

410932



410933



410934



410941

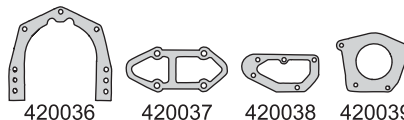

420036

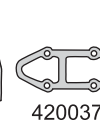

420037



420038

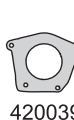

420039

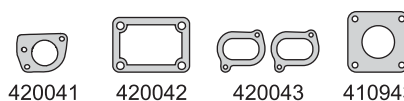

420041

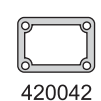

420042



420043

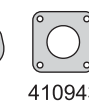

410943

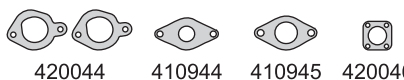

420044

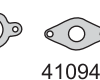

410944



410945



420046

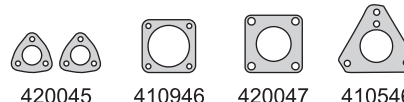

420045

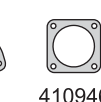

410946

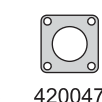

420047



410546

○ ○ ○ ○ ○ ○
A 10 x 21 x 2 C



R400211P



R400012P

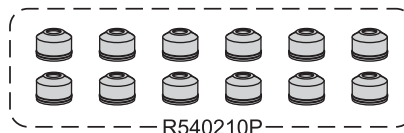

R540210P

PERKINS



Motor/Engine	Cm³	HP	Ø
4.203 - 8 BR Iny. Indirecta	3336	71	91.49
DIESEL			

Perkins: Tractor 8 BR



Nº OE	Descripción/Description	Mat.	Ref.
420302/420310	Jgo. de juntas para motor		420100-R
	Jta. tapa cilindros Ø 92.5 ± 1.40	NFT 1	400005
36812125	Jta. tapa cilindros Ø 92.5 ± 1.40	NFT	400007
36812125	Jta. tapa cilindros Ø 92.5 ± 1.15	CNC	400008
	Jgo. tornillos tapa cilindros (HAS19038)		B400000
0490704	Conj. junta tapa válvulas (4)	CG 1	400010
0999725	Jgo. junta para cárter (4)	NB 1	420111
36814112	Tapa distribución	NB 1	400012
38866615	Block caja distribución	NB 1	400013
006002	Bomba agua placa trasera	NB 1	410514
00490042	Múltiple escape	FCH 2	400015
80490032	Múltiple admisión	NFT 1	400017
	Salida de escape	FCH	400018
0920113	Salida de escape	NFT 1	410518
	Arandela tapa válvulas (3)	GS 3	400130
70190014	Tapa inferior cárter	NB 1	420133
066081	Tapa frontal a tapa inspección	NB 1	400034
0490485	Tapa trasera cigüeñal	NB 1	400035
36846409	Tapa trasera tapa cilindro	NB 1	400036
36864114	Inspección trasera	CG 1	420136
	Inspección delantera	CG 1	420137
70490109	Bomba aceite hidráulico	NB 1	420138
36866416	Salida de escape	NFT 1	410538
70490063	Caja distribución bomba vacío	NB 1	400039
	Caja distribución adaptador	NB 1	420139
006007	Cubierta cigüeñal	NB 1	410539
0490699	Comando bomba combustible	NB 1	400146
0490692	Tapa trasera árbol levas	NB 1	400047
36835411	Conexión entrada agua	NB 1	400048
	Desvío agua	NB 1	410549
0490701	Conexión salida agua	NB 1	400051
36817141	Salida agua a tapa	NB 1	400052
70730006	Filtro aceite a block	NB 1	400057
	Jgo. empaquetadura bancada cigüeñal (2)	SLA 1	400158
36866414	Jgo. empaquetadura bancada cigüeñal (2)	SNA	410958
36862152	Bomba vacío tapa brida	NB 1	400062
36865543	Bomba alimentación combustible	NB 1	400165
	Soporte bomba inyectora	NB 1	400066
0490702	Arandela A 40 x 47 x 0.85 C	CU 4	
33825409	Arandela base inyector A 14 x 20 x 1.5 C	CU 4	
	Arandela A 10 x 21 x 2 C	CU 4	
	O´ring G 21.82 x 3.53	GS 1	
	Kit de retenes completo		R420100
	Jgo. retén válvulas (8)	P 1	R420410P
	Retén distribución 57.30 x 76.20 x 12.70	N 1	R420112N
	Retén auxiliar 22.22 x 34.92 x 6.35	N 1	R400213N

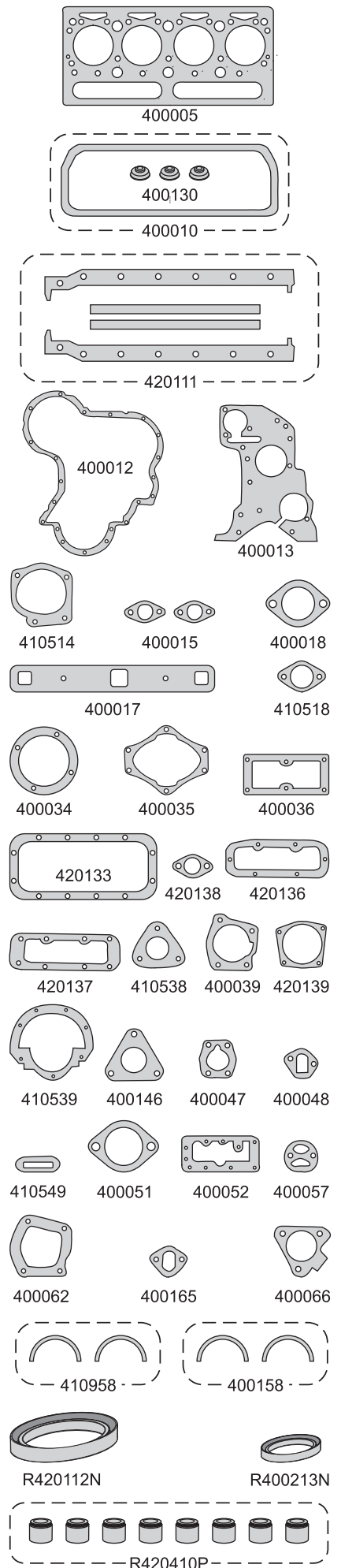

PERKINS

PERKINS



Motor/Engine	Cm³	HP	Ø
4.236	3860	70	98.4
4.248	4070	100	100
Iny. Directa			
DIESEL			

Perkins: Case 580H



Nº OE	Descripción/Description	Mat.	Ref.
	Jgo. de juntas para motor		420200-R
	Junta tapa de cilindros Ø 104 ±1.70	NFT	410605
36812338	Junta tapa de cilindros Ø 104 ±1.70	NFT	1 410607
70490149	Junta tapa válvulas	CG	1 410610
36815706	Junta para cárter	NB	1 410611
	Tapa distribución	NB	1 420212
36814127	Placa distribución	NB	1 410613
	Cuerpo bomba de agua	NB	1 420214
36866724	Tapa bomba de agua trasera	NB	1 410614
36886007	Jgo. múltiple escape (2)	NFT	1 280316
	Jgo. múltiple admisión (3)	NFT	1 280317
0490301	Salida de escape	FCH	1 400218
	Conexión entrada de agua	NB	1 420219
	Base bomba nafta	NB	1 550628
C7NN-6659-A	Bomba aceite a block	NB	1 330030
70490146	Bomba de agua	NB	1 410731
36853514	Cuerpo salida de agua	NB	1 410632
0921173	Arandela inyector A 10 x 20 x 1.5 A	AL	410533
36851409	Tapa trasera tapa de cilindros	NB	1 410633
	Placa al block	NB	1 420234
36862517	Filtro de aceite	NB	1 410634
70490091	Succión bomba aceite	NB	1 410934
36834143	Bomba inyectora	NB	1 400435
0490734	Carcasa termostato	NB	1 410635
36817157	Porta retén trasero	NB	1 400236
	Filtro aceite lubricante	NB	2 420236
36862151	Conexión superior salida de agua	NB	1 410637
36865511	Caja distribución bomba vacío	NB	1 400039
7049145	Cuerpo delantero y trasero bomba de agua	NB	1 410640
36835425	Carcasa a conexión superior	CG	1 410641
	Turbina - entrada aceite	NB	1 420241
36851113	Bomba alimentación a block	NB	2 410642
	Block tomada de potencia	NB	1 420242
36832122	Tubo succión bomba de aceite	NB	1 410643
36832404	Succión bomba de aceite	NB	1 410743
	Filtro aceite lubricante	NB	1 420243
32811113	Basón tapa interior a block	GS	2 400442
0490355	Tubo succión a válvula alimentación	NB	1 410644
36862138	Boca lubricación	NB	1 410744
36825107	Inspección engranaje comando auxiliar	NB	1 400244
	Tapa tomada de fuerza	NB	1 420244
36822111	Múltiple de escape	NFT	1 410645
	Block balanceador dinámico	NB	1 420245
0490773	Comando bomba inyectora	NB	1 400146
70490100	Acoplamiento bomba inyectora	NB	1 410546
32811408	Anillo lubricación tapa cilindros G 6 x 10 x 5.2	GS	410646
	Adaptador vacío	NB	1 410747
	O´ring G 21 x 35 x 13	GS	4
	O´ring G 7.2 x 11 x 6	GS	1
	Arandela A 10 x 20 x 20 C	CU	4
	Jgo. retén válvulas (8)	P	1 R300310P
	Retén bancada 133.35 x 158.75 x 11/13	P	1 R400211P
	Retén distribución 60.32 x 79.36 x 9.5	P	1 R400012P

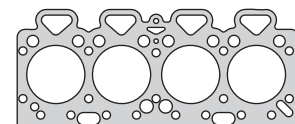

410607

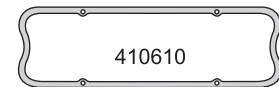

410610

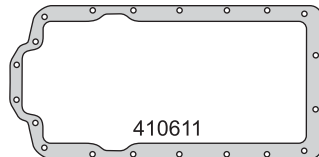

410611

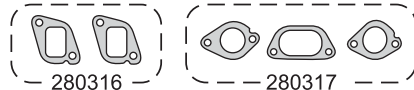

280316

280317



420212

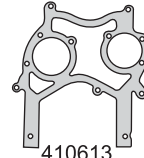

410613

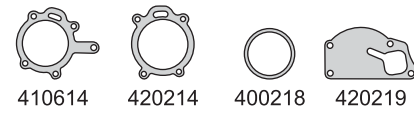

410614

420214

400218

420219

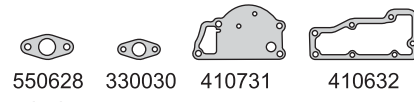

550628

330030

410731

410632



410533

410633

410634

400435

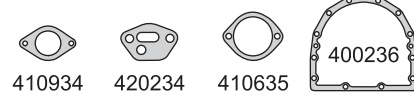

410934

420234

410635

400236

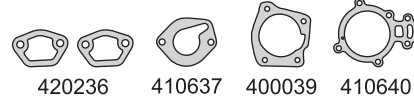

420236

410637

400039

410640

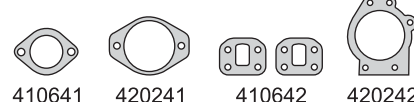

410641

420241

410642

420242

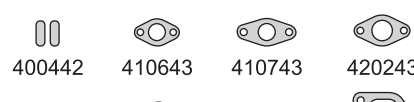

400442

410643

410743

420243



420244

410644

410646

410744



400244

410645

420245

400146

410546

410747



R400211P



R400012P

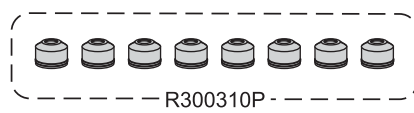

R300310P

PERKINS

PERKINS



Motor/Engine	Cm³	HP	Ø
3.152	2360	42	89
3.152	2502	42	91.44

Massey Ferguson: 50/50X/55X/135/200/235/250
MF 135/515



DIESEL

Nº OE	Descripción/Description	Mat.	Ref.
315202/315205	Jgo. de juntas para motor		420400-R
36812122	Junta tapa de cilindros Ø 93 \pm 1.45	NFT	400507
368112122	Junta tapa de cilindros Ø 93 \pm 1.45	FCH	400508
	Jgo. tornillos tapa cilindros (HAS19038)		B400000
0490491	Conj. junta tapa válvulas (3)	CG	400510
003249	Jgo. junta para cárter (3)	NB	400511
36813136	Tapa distribución	NB	420412
36814119	Placa distribución	NB	400513
0490484	Bomba agua a placa	NB	420414
0490481	Múltiple escape (2)	FCH	400015
0490184	Salida de agua	NB	200025
	Arandela tapa válvulas	GS	400130
0490251	Tapa filtro aceite	NB	420433
36837408	Tapa bomba hidráulica	NB	420434
0490482	Cuerpo salida agua	NB	400534
006081	Tapa trasera cigüeñal	NB	400035
70490034	Tapa trasera	NB	420435
0490485	Tapa trasera tapa cilindros	NB	400036
0490738	Cuerpo salida agua tapa cilindros	NB	400536
36862511	Tapa trasera árbol levas	NB	400537
70490014	Salida de escape	NFT	410538
0490486	Tapa conexión entrada aire	NB	400539
36862512	Tapa inspección carga aceite	NB	400540
36862165	Bomba alimentación	NB	400541
0490685	Comando bomba combustible	NB	400146
006047	Filtro aceite a block	NB	400057
70730006	Jgo. empaquetadura cigüeñal (2)	SNA	400158
	Arandela A 10 x 21 x 2 C	CU	
	Arandela A 14 x 20 x 1.5 C	CU	
	Arandela A 40 x 47 x 0.85 C	CU	
	O'ring G 44.17 x 1.78	GS	
	Kit de retenes completo		R420400
	Jgo. retén válvulas (6)	P	R420410P
	Retén distribución 57.30 x 76.2 x 12.70	N	R420112N
	Retén árbol levas 22.2 x 34.92 x 6.35	N	R400213N

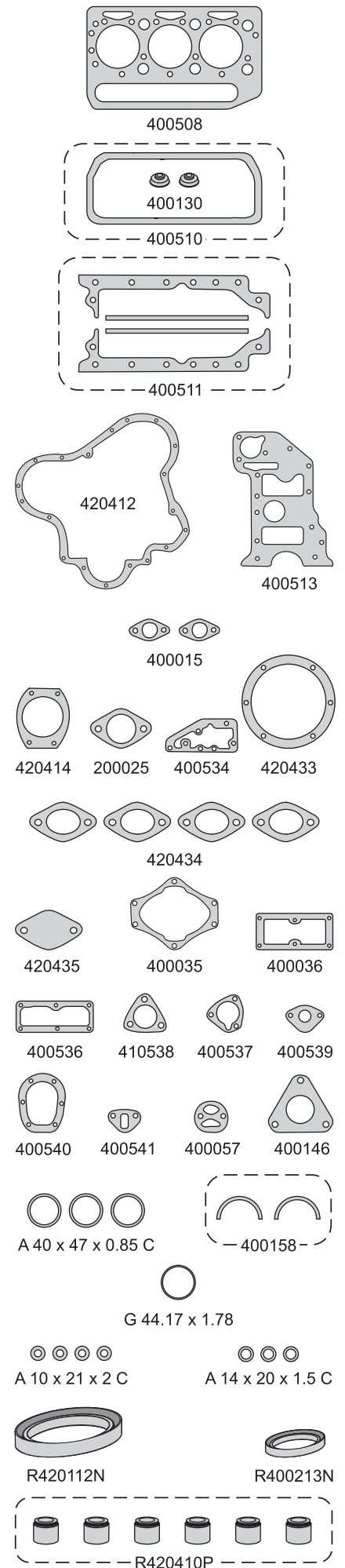

PERKINS

PERKINS



Motor/Engine	Cm³	HP	Ø
Prima 65/80T Leyland Prima 65 Daf TN 44	1994	64/80	84.45

Perkins: Rover - Maestro D/TD
Perkins - Marino 4.20 D/TD
Leyland Sherpa 185/200/215/220/230
240/255 1986/94
Daf Ka 200/ VS 200 1986/...



DIESEL

Nº OE	Descripción/Description	Mat.	Ref.
	Jgo. de juntas para motor		420600-R
L681EF06	Junta tapa de cilindro Ø 86 ±1.50	NFT	1 420607
L681KF03	Junta para cárter	NB	1 420611
L687YF02	Frente motor para bomba aceite a block	NB	1 420612
L681VF02	Múltiple admisión y escape	NFT	1 420615
006155	Salida de escape	AC	1 420618
L683NF02	Retorno agua termostato	NB	1 420619
L687MF03	Conexión salida de agua	NB	1 420621
L687MF13	Cuerpo salida agua a tapa de cilindros	NB	2 420622
L687MF05	Codo a múltiple admisión	NB	1 420623
006165	Caja drenaje aceite	NB	2 420624
L683NF02	Junta conexión salida agua	NB	2 420626
L683HF01	Junta carga aceite a block	NB	1 420627
L687MF14	Bomba aceite a cabezal	NB	1 420636
006167	Placa adaptador a block trasero	NB	1 420637
L683HF05	Tubo carga aceite a block	NB	1 420638
L688CF01	Turbo a salida escape	NFT	2 420639
	Entre múltiple turbo	AC	1 500546
36862126	Bomba combustible	NB	400165
	Arandela A 6.5 x 10 x 1 C	CU	8
	Arandela A 8 x 11 x 1 A	AL	8
	Arandela A 8 x 14 x 1.5 C	CU	4
	Arandela A 20 x 26 x 1 A	AL	2
	Arandela A 14 x 20 x 1.5 C	CU	1
	Arandela A 20 x 25 x 2 A	AL	1
	Arandela A 14 x 18 x 1.5 A	AL	1
	O´ring G 47.29 x 2.62	GS	1
	O´ring G 20 x 2	GS	1
	Kit de retenes completo		R420600
	Jgo. retén válvulas (8)	P	1 R420610P
	Retén bancada 88. 9 x 105 x 9.5	P	1 R420611P
	Retén distribución 35 x 45 x 7	P	1 R420612P
	Retén árbol de levas trasero 40 x 52 x 7	P	1 R420613P
	Retén árbol de levas trasero 45 x 60 x 7	P	1 R420614P

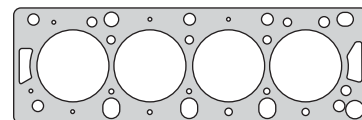

420607

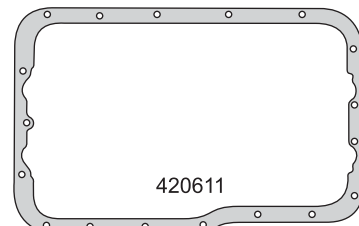

420611



420615

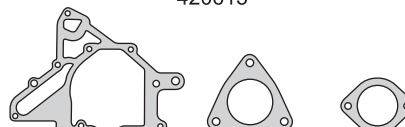

420612

420618

420619



420621

420622

420623



420624

420638

420626

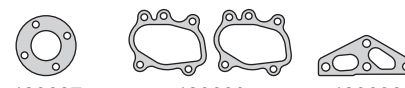

420627

420639

420636

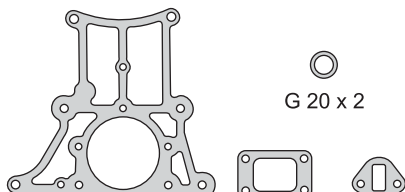

420637

500546

400165



A 20 x 25 x 2 A

A 20 x 26 x 1 A

A 8 x 14 x 1.5 C

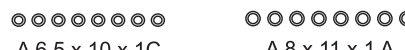

A 6.5 x 10 x 1 C

A 8 x 11 x 1 A

G 47.29 x 2.62

A 14 x 20 x 1.5 C

A 14 x 18 x 1.5 A



R420612P

R420611P

R420614P



R420610P

PERKINS

PERKINS



Motor/Engine	Cm³	HP	Ø
D3.152-D3.152/2 G3.152-D3.152/4 Iny. Directa	2500	100	91.40

Perkins: MF133/135/148/230/235/240/254/353
Industrial MF40 - Agrícola/Marino



DIESEL

Nº OE	Descripción/Description	Mat.	Ref.
	Jgo. de juntas para motor		● 422000-R
	Junta tapa cilindro Ø 93 ±1.40	NFT	1 420205
	Junta tapa válvulas	CG	1 422010
	Jgo. junta para cárter (4)	NB	1 422011
	Tapa distribución	NB	1 420412
	Placa distribución	NB	1 400513
	Bomba de agua	NB	1 420414
	Jgo. múltiple escape (3)	AC	1 400416
	Múltiple admisión	NB	1 422017
	Salida de agua	NB	1 200025
	Tapa filtro aceite		422033
	Cuerpo salida de agua	NB	1 400534
	Tapa trasera cigüeñal	NB	1 400035
	Tapa trasera a block	NB	1 422035
	Tapa trasera tapa cilindros	NB	1 400036
	Porta retén bancada trasero	NB	1 400038
	Tapa conexión entrada de aire	NB	1 400539
	Tapa inspección delantera	NB	1 400540
	Bomba alimentación	NB	1 400541
	Comando bomba combustible	NB	1 400146
	Filtro aceite a block	NB	1 400057
	Jgo. empaquetadura cigüeñal (2)	SLA	1 400158
	Arandela inyector A 10 x 20 x 2 C	CU	3
	Kit de retenes completo		R422000
	Jgo. retén válvulas (8)	P	1 R300310P
	Jgo. retén válvulas (8)	P	1 R400010P
	Retén bancada 133.35 x 158.75 x 11/13		P 1 R400211P
	Retén distribución 57.3 x 76.2 x 12.70		N 1 R420112N

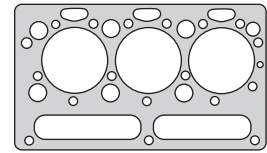

420205



422010

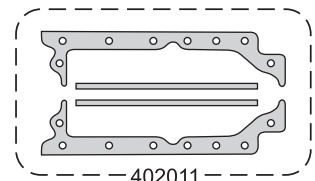

422011

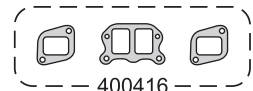

400416

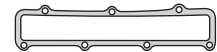

422017

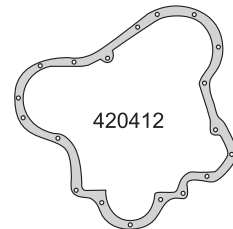

420412

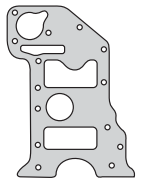

400513



420414



200025

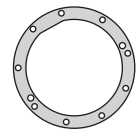

400038



422035



400534

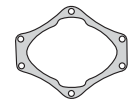

400035

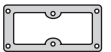

400036



400539



400541



400057



400540

A 10 x 20 x 2 C



400146



400158



R400211P



R420112N

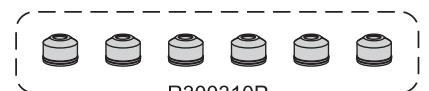

R300310P



R400010P

PERKINS



taranto

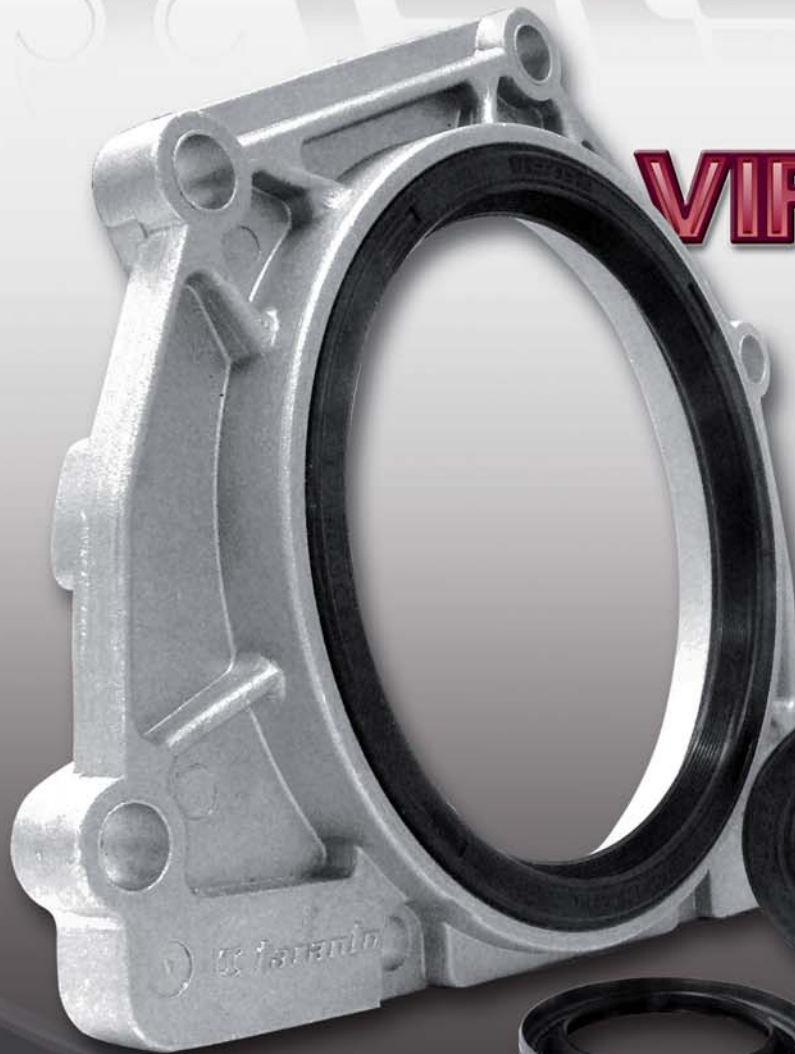

VIFLON®



Revolucionario diseño de labio en VIFLON® VF

Como resultado de la permanente búsqueda de mejores diseños y materiales para ofrecer al mercado productos más eficientes a costos razonables, Taranto ha desarrollado nuevos perfiles de labio con mejores características y costo más bajo que los retenes PTFE.

VENTAJAS DE ESTE NUEVO DISEÑO Y COMPUESTO

- ▶ Contacto más estrecho con el eje.
- ▶ Menor carga sobre el eje por su diseño sin resorte.
- ▶ Menor coeficiente de fricción respecto al compuesto fluoroelastómero FKM.
- ▶ Mejor flexibilidad del labio con una mejor adaptación a ejes usados.
- ▶ Menor costo respecto al PTFE.



SCANIA



Motor/Engine	Cm³	HP	Ø
D11 - DS11	11020	280/333	127

Scania: Camión - Omnibús L75- 76
L - LB - LBS 110 - L111 - LB111 - LS111
LT111 - LBS111 - LBT111 1974/...



DIESEL

Nº OE	Descripción/Description	Mat.	Ref.
	Jgo. de juntas para motor		810000-R
	Jgo. de juntas superior		810095
161870	Jta. tapa cilindros Ø 144 \pm 1.40	NFT 2 2	810007
161870	Jta. tapa cilindros Ø 144 \pm 1.80	FCH	810008
258459	Junta tapa válvulas superior	CG 2 2	810010
131144	Jgo. junta para cárter (4)	NH 1 1	810011
287553	Tapa distribución	NB 1 1	810012
287554	Placa distribución	NB 1 1	810013
231795	Tapa bomba de agua	NB 1 1	810014
	Jgo. múltiple escape (4)	GFT 1 1	810015
139108	Múltiple admisión	CB 2 2	810017
152667	Salida de escape	NFT 1 1	810018
139044	Base termostato	CB 2 2	810019
139274	Tapa inspección distribución	CB 1 1	810029
131305	Soporte dínamo	NB 1 1	810030
291826	Salida termostato	CB 2 2	810031
35309	Tapa inspección botadores	CB 1 1	810032
35161	Cañería bomba agua	NB 1 1	810033
278602	Unión múltiple cara agua	NB 1 1	810034
	Retén cigüeñal	FIE 1 1	810035
181333	Tapa válvulas lateral	NB 2 2	810036
302226	Tapa inspección distribución	CB 1 1	810037
287555	Carcaza volante	NB 1 1	810038
277632	Tapa colector admisión	NFT 2 2	810039
	Kit de retenes completo		R810000
	Jgo. retén válvulas (12)	P 1 1	R810010P
	Retén bancada 130 x 160 x 15	V 1 1	R810111V
	Retén distribución 80 x 100 x 12	V 1 1	R810115V
	Retén auxiliar 35 x 62 x 7	N 1 1	R810012N

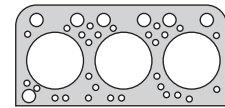

810007

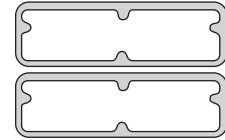
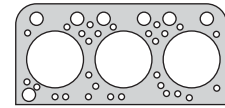

810010

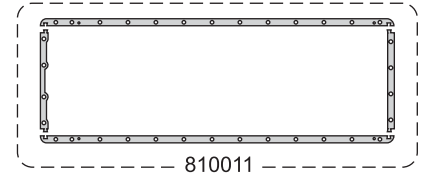

810011

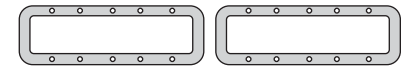

810036



810039

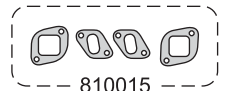

810015

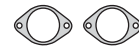

810017

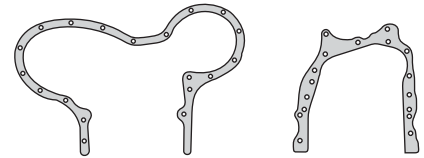

810012

810013

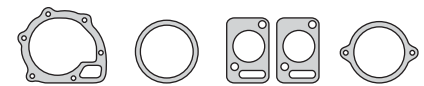

810014

810018

810019

810029

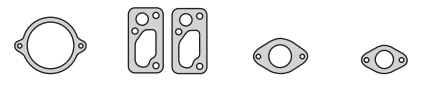

810030

810031

810032

810033

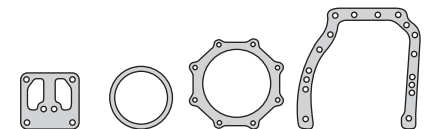

810034

810035

810037

810038



810012N

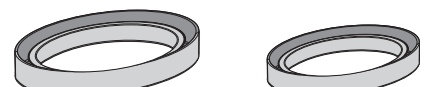

810111V

810115V

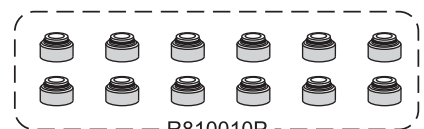

810010P

SCANIA



Motor/Engine	Cm³	HP	Ø
D11/DS11/DSC11 DN11/DTC11	11020	272/354	127

Scania: LB110 - LBS110 - L111 - LS111
 LT111 - LBS111 - LBT111 - G112 - L112
 R112 - T112 - P113 - P113HK - R113
 R113HK - T113 - K113CBL
 K113GLP - K113TLB
 K113TLP 1975/...



DIESEL

Nº OE	Descripción/Description	Mat.	Ref.
	Jgo. de juntas para motor		810100-R
	Jgo. de juntas para motor		810101-R
	Jgo. de juntas superior		810195
346143	Jta. tapa cilindros Ø 147 ± 1.25	ACG	2 810108
258459	Junta tapa válvulas superior	CG	2 2 810010
215242	Jgo. junta para cárter (4)	NH	1 810011
287553	Tapa distribución	NB	1 810012
1388680	Tapa distribución 112/113	NB	1 810312
287554	Placa de distribución	NB	1 810013
231795	Bomba de agua	NB	1 810014
	Jgo. múltiple escape (4)	GFT	1 1 810015
1384554/5	Jgo. múltiple escape (4)	GFT	1 1 810316
	Múltiple admisión	NFT	1 1 810117
1301628/29	Jgo. múltiple admisión (6) - 113	NFT	1 1 810317
	Salida de escape	NFT	1 1 810218
283148	Termostato	NB	1 810119
	Tapa termostato 112/113	NB	1 810219
	Bomba de agua	CB	1 810319
225835	Bomba de aceite	NB	1 810227
139274	Tapa inspección distribución	CB	1 810029
291826	Salida termostato	CB	2 2 810031
	Tapa termostato	NB	2 810231
35309	Tapa inspección botadores	CB	1 810032
	Anillo G 46 x 34 x 2	GS	1 810232
35161	Cañería bomba de agua	NB	1 810033
	Anillo G 42 x 57 x 3	GS	2 810233
278602	Unión múltiple a cámara agua	NB	1 1 810034
	Anillo G 29.5 x 17.5	GS	810234
181383	Junta tapa válvulas lateral	NB	2 810036
302226	Tapa inspección distribución	CB	1 810037
163142	Tapa inspección distribución	CB	1 810137
170765	Base filtro aceite	NB	1 810237
287555	Carcaza volante	NB	1 810038
238403	Soporte filtro aceite	NB	1 810238
277632	Tapa colector admisión	NFT	2 2 810039
232961	Soporte enfriador aceite	NB	1 810239
139123	Soporte balancines	CB	12 12 810140
	Jgo. juntas compresor KH2 Bus	VS	810240
384464	Entre múltiples	NFT	1 1 810243
	Brida	NB	1 810144
	Múltiple admisión	NFT	1 1 810244
	Retorno aceite a block	NB	1 810245
	Arandela tapón cárter	AL	810246
	Retén bomba aceite a block	NB	1 810247
	Jgo. juntas caja velocidades	VS	810150
	Jgo. juntas caja velocidades K112 Bus	VS	810250
	Jgo. juntas caja velocidades 113/114/124	VS	810350
	Jgo. juntas caja velocidades 113/114/124	VS	810351
	Jgo. juntas caja veloc. K113 Bus - P93/94	VS	810352
	Tapa diferencial 111/112	AL	810159
	Turbina turbocompresor	AC	1 1 810162
	Varilla medición aceite	NB	1 810262
	Turbina turbo	AC	1 1 810362

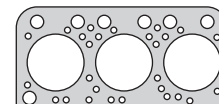

810108

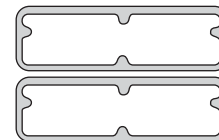
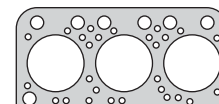

810010

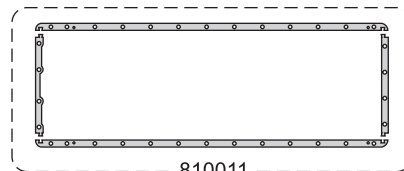

810011



810036



810039

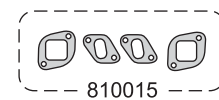

810015

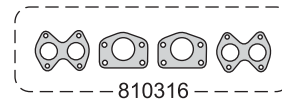

810316

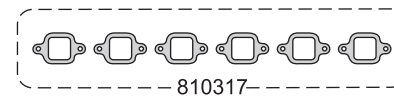

810317

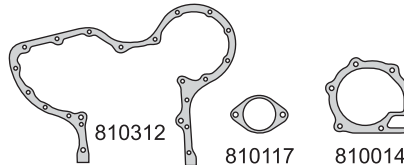

810312

810117

810014

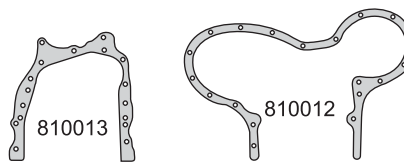

810013

810012

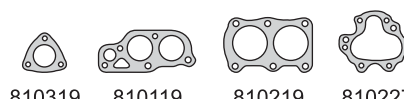

810319

810119

810219

810227

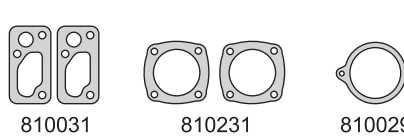

810031

810231

810029

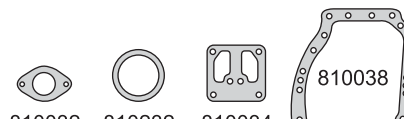

810032

810232

810034

810038



810233

810033

810237

810037

SCANIA



Motor/Engine	Cm³	HP	Ø
D11/DS11/DSC11 DN11/DTC11	11020	272/354	127
DIESEL			

Scania: LB110 - LBS110 - L111 - LS111
 LT111 - LBS111 - LBT111 - G112 - L112
 R112 - T112 - P113 - P113HK - R113
 R113HK - T113 - K113CBL
 K113GLP - K113TLB
 K113TLP 1975/...



Nº OE	Descripción/Description	Mat.	1	2	Ref.
	Base turbocompresor	AC	1	1	810163
	Base turbo	AC	1	1	810363
	Retorno turbo	NB	1	1	810364
	Entrada aceite a turbo	NB	1	1	810365
	Salida aceite a turbo	NB	1	1	810366
	Entrada turbo 112/113 1991/...	NB	1	1	810367
	O'ring G 10 x 2.5	GS		2	
	O'ring G 29.2 x 3	GS		2	
	O'ring G 126.67 x 2.62	GS			
	O'ring G 12.37 x 2.62	GS		2	
	O'ring G 122 x 5	GS			
	O'ring G 16 x 2.5	GS		1	
	O'ring G 19.25 x 2.9	GS		4	
	O'ring G 23.47 x 2.62	GS		2	
	O'ring G 26.2 x 3	GS		1	
	O'ring G 22.2 x 3.5	GS		2	
	O'ring G 20 x 4	GS		2	
	O'ring G 53.5 x 3	GS		1	
	O'ring G 45 x 3	GS		1	
	O'ring G 72.69 x 2.62	GS		1	
	O'ring G 102.5 x 94.5	GS			
	O'ring G 107.54 x 3.53	GS			
	O'ring G 110.72 x 3.53	GS			
	O'ring G 17.5 x 6	GS		4	
	Arandela A 10 x 14 x 1.5 A	AL	10	10	
	Arandela A 8 x 11 x 1 C	CU	20	20	
	Arandela A 14 x 20 x 1.5 A	CU	20	20	
	Arandela A 10 x 19 x 2 C	CU	6	6	
	Arandela A 24 x 38 x 1.25 A	AL		1	
	Kit de retenes completo				R810000
	Jgo. retén válvulas (12)	P		1	R810010P
	Retén bancada 130 x 160 x 15	V		1	R810111V
	Retén auxiliar 35 x 62 x 7	N		1	R810012N
	Retén distribución 80 x 100 x 12	V		1	R810115V

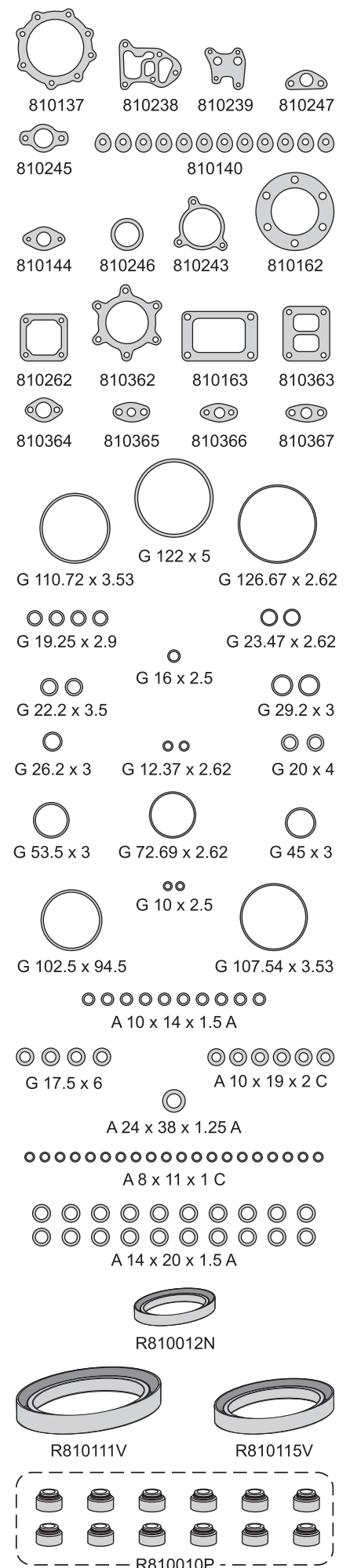

SCANIA



taranto



Sistemas de Embrague Taranto Premium

Diseñado para resistir las altas temperaturas generadas durante su funcionamiento, garantizando el óptimo desempeño en las más exigentes condiciones.

- Suavidad de acople en arranques y cambios de velocidades
- Transmisión de fuerza garantizada
- Óptima resistencia térmica
- Mayor confort y durabilidad
- Soporta altas exigencias
- Bajo esfuerzo operativo.



INCLUYE RODAMIENTOS

SKF

SHANGAI



Motor/Engine	Cm³	HP	Ø
495A Tracción Simple			
485A 18 Tracción Doble			

Shangai: Tractor



DIESEL

Nº OE	Descripción/Description	Mat.	Ref.
	Jgo. de juntas para motor		910900
	Junta tapa de cilindros Ø 101 \pm 1.40	NFT 1	910905
	Junta tapa válvulas	GS 1	910910
	Jgo. junta para carter (2)	NB 1	910911
	Tapa distribución	NB 1	910912
	Placa distribución	NB 1	910913
	Bomba de agua	NB 1	910914
	Múltiple escape	NFT 1	910916
	Jgo. múltiple admisión (2)	NB 1	910917
	Salida de escape	NFT 1	910918
	Base bomba de agua	NB 1	910919
	Bomba aceite	NB 1	910927
	Junta gaseador	CG 1	910928
	Junta bomba aceite	NB 1	910929
	Cámara de agua	NB 1	910932
	Cámara de agua trasera	NB 1	910933
	Junta	NB 1	910934
	Junta acople termostato	NB 2	910935
	Junta lateral block	NB	910936
	Junta superior distribución	NB 1	910937
	Cámara lateral	CG 1	910938
	Acople salida motor	NB 1	910939
	Bomba inyectora	NB 1	910940
	Bomba inyectora	NB 1	910942
	Junta acople distribución	NB 1	910943
	Bomba de aceite	NB 1	910944
	Tapa bomba de agua	NB 1	910945

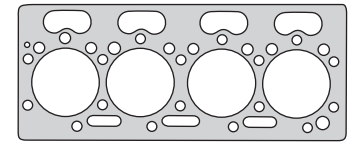

910905



910910

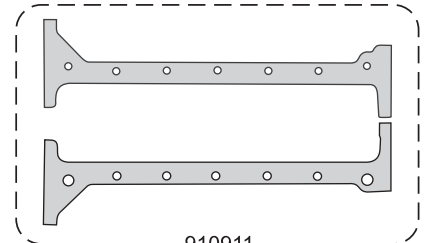

910911



910916

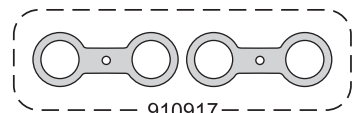

910917

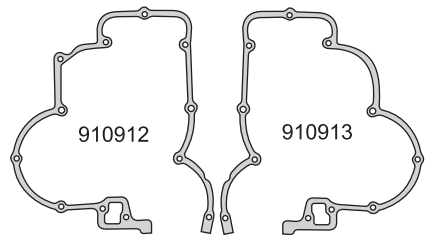

910912

910913

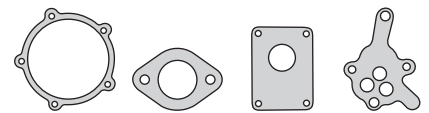

910914

910918

910919

910927

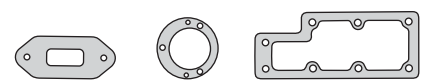

910928

910929

910932



910933

910934

910935

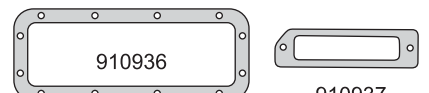

910936

910937



910938

910945

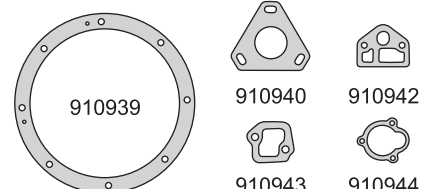

910939

910940

910942

910943

910944



taranto



HANC12130K

Kit Atornilladora Neumática - Encastre de 1/2"

- ▶ Atornilladora Trabajo Pesado en Aluminio Pulido, encastre 1/2" (12mm).
- ▶ Doble martillo.
- ▶ Torque Máximo 950ft/lbs (1288Nm).
- ▶ Material Composite Alta Resistencia, Ultra Liviano.
- ▶ Tubos Cromo-Molibdeno Alto Impacto Standart. (Medidas 17,19 y 21mm).
- ▶ Tubos Cromo-Molibdeno Alto Impacto largos, pared fina. (Medidas 17,19 y 21mm).



VOLVO



Motor/Engine	Cm³	HP	Ø
THD 101 KC	9600	273/310	120.6

Volvo: B58 - B10M 1987/...



DIESEL

Nº OE	Descripción/Description	Mat.	Ref.
	Jgo. de juntas para motor		880000-R
270.789	Junta tapa cilindros Ø 136.5 ± 1.40	ACG	6 880008
424693.0	Junta tapa válvulas superior	GS	6 880010
424607	Jgo. junta para cárter (4)	NB	1 880011
468116	Delantera distribución	NB	1 880012
468557	Placa de distribución	NB	1 880013
479107	Jgo. múltiple escape (6)	NFT	1 880015
424618	Junta admisión	NFT	1 880017
424694.8	Tapa válvulas inferior	GS	6 880031
	Tapa válvulas lateral	GS	3 880036
	Lateral cámara de agua	NB	880037
	Enfriador de aceite	NB	1 880038
	Guarnición goma (verde claro)	GS	6 880039
	Kit de turbina (bipartida) (4)	VS	1 880040
	Guarnición	GS	1 880043
	Guarnición	GS	1 880044
	Anillo G 24 x 30 x 6	GS	3 880045
	Anillo G 18 x 23 x 3	GS	6 880046
	Kit de arandelas (87)	VS	1 880047
	Kit de gomas (134)	VS	1 880048
	Turbina turbo	AC	1 810362
	Base turbo	AC	1 810363
	Entrada aceite a turbo	NB	1 810365
	Entrada turbo	NB	1 810367
	Arandela A 8 x 12 x 1 C	CU	17
	Arandela A 12 x 20 x 1.5 C	CU	11
	Arandela A 14 x 24 x 2 C	CU	21
	Arandela A 16 x 22 x 1.5 C	CU	3
	Arandela A 18 x 22 x 1.5 C	CU	4
	Arandela A 20 x 24 x 1.5 C	CU	1
	Arandela A 24 x 30 x 1.5 C	CU	3
	Arandela A 10 x 14 x 1.5 A	AL	2
	Arandela A 22 x 27 x 1.5 A	AL	1
	Arandela A 8 x 15 x 1.5 C	CU	24
	Anillo A 45 x 50 x 1.4 PL	PLAST	6
	Anillo A 38 x 43 x 1.5 PL	PLAST	12
	Anillo A 30 x 35 x 1 PL	PLAST	1
	O'ring G 23 x 32 x 5	GS	6
	O'ring G 22 x 28 x 3	GS	2
	O'ring G 65 x 7	GS	1
	O'ring G 58 x 7	GS	1
	O'ring G 44 x 56 x 10	GS	5
	O'ring G 35 x 45 x 7	GS	6
	O'ring G 20 x 27 x 4	GS	6
	Anillo G 20 x 28 x 13	GS	5
	Anillo G 95 x 100 x 3.5	GS	1
	Anillo G 21 x 28 x 3	GS	3
	Anillo G 35 x 45 x 6.6	GS	4
	Anillo G 34 x 39 x 3	GS	3
	Anillo múltiple de escape G 75 x 81.8 x 4.5	GS	6
	Anillo G 20 x 28 x 7.5	GS	4
	Anillo G 71 x 78 x 4	GS	1
	Anillo G 46 x 55 x 4.5	GS	1

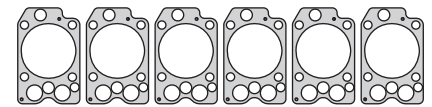

880008

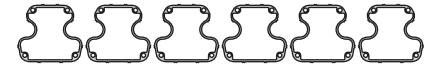

880010



880011



880012

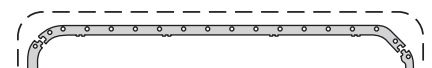

880013

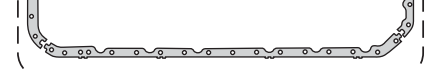

880015



880017



880031



880036

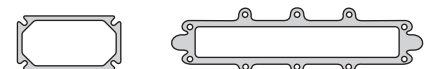

880037

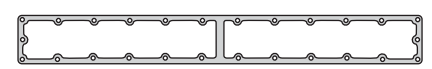

880038



880039



810362

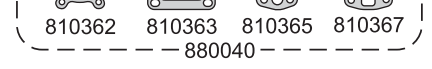

810363



810365



810367



880040



880043

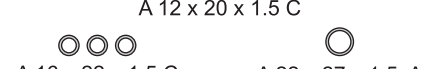

880044



880046

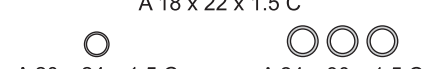

880045



A 14 x 24 x 2 C

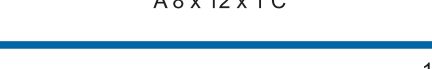

A 8 x 15 x 1.5 C



A 12 x 20 x 1.5 C

A 16 x 22 x 1.5 C

A 22 x 27 x 1.5 A

A 18 x 22 x 1.5 C

A 20 x 24 x 1.5 C

A 24 x 30 x 1.5 C

A 8 x 12 x 1 C

VOLVO



Motor/Engine	Cm³	HP	Ø
THD 101 KC	9600	273/310	120.6

Volvo: B58 - B10M 1987/...

DIESEL



Nº OE	Descripción/Description	Mat.	Ref.
	Anillo G 25 x 29 x 3	GS 2	
	Anillo G 18 x 24 x 8	GS 1	
	Anillo G 13 x 20 x 5	GS 2	
	Anillo G 27 x 20 x 3	GS 1	
	Anillo G 40 x 34 x 3	GS 1	
	O´ring G 34 x 3	GS 2	
	O´ring G 19 x 3	GS 5	
	O´ring G 64 x 3	GS 1	
	O´ring G 56 x 3.4	GS 2	
	O´ring G 38 x 5	GS 2	
	O´ring G 49 x 3	GS 4	
	O´ring G 17 x 2	GS 2	
	O´ring G 26 x 3	GS 1	
	O´ring G 43 x 3	GS 1	
	O´ring G 116 x 3	V 1	
	Kit de retenes completo		R880000
	Retén bancada 155 x 180 x 15	V 1	R880011V
	Retén distribución 85.72 x 114.33 x 13	V 1	R880012V
	Retén árbol de levas 30 x 50 x 7.5	V 1	R340312V

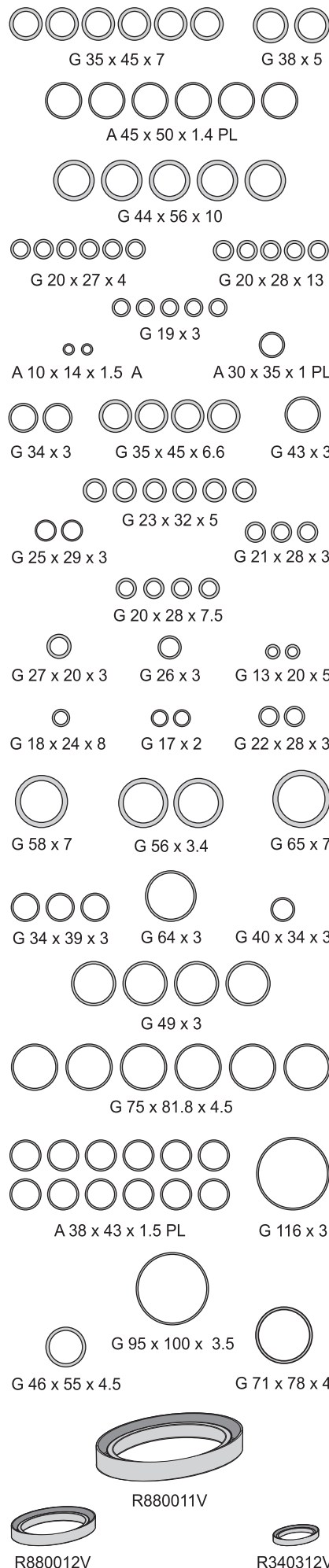

VOLVO



Motor/Engine	Cm³	HP	Ø
THD 100D	9600	230/260	120.6

Volvo: B58 1980/85



DIESEL

Nº OE	Descripción/Description	Mat.	Ref.
	Jgo. de juntas para motor		880100-R
275.551	Junta tapa cilindros Ø 130 \pm 1.40	ACG 6	880108
423145.2	Junta tapa de válvulas	GS 6	880110
424.607	Jgo. junta para cárter (4)	NB 1	880011
	Delantera de distribución	NB 1	880112
468.557	Placa de distribución	NB 1	880013
	Jgo. múltiple escape (6)	NFT 1	880115
422.616	Junta admisión	NFT 1	880117
423146.2	Junta tapa de válvulas	GS 6	880131
	Junta lateral tapa de válvulas	GS 3	880036
	Guarnición goma (verde claro)	GS 6	880039
	Kit de turbina (un agujero) (4)	VS 1	880140
	Guarnición goma	GS 1	880044
	Anillo G 18 x 23 x 3	GS 4	880046
	Anillo G 15 x 18 x 4	GS 1	880146
	Kit de arandelas (84)	VS 1	880147
	Kit de gomas (104)	VS 1	880148
	Turbina turbo	AC 1	810362
	Escape turbo	AC 1	880263
	Entrada de aceite a turbo	NB 1	810365
	Entrada turbo	NB 1	810367
	Anillo múltiple escape G 75 x 81.8 x 4.5	GS 6	
	Arandela A 8 x 12 x 1 C	CU 17	
	Arandela A 12 x 20 x 1.5 C	CU 11	
	Arandela A 14 x 24 x 2 C	CU 20	
	Arandela A 16 x 22 x 1.5 C	CU 3	
	Arandela A 18 x 22 x 1.5 C	CU 5	
	Arandela A 20 x 24 x 1.5 C	CU 1	
	Arandela A 22 x 28.5 x 2 C	CU 2	
	Arandela A 24 x 30 x 1.5 C	CU 1	
	Arandela A 26.5 x 31.5 x 1.5 C	CU 2	
	Arandela A 8 x 12 x 1.5 A	AL 1	
	Arandela A 8 x 13 x 1.5 A	AL 21	
	Anillo A 45 x 50 x 1.4 PL	PLAST 6	
	Anillo A 38 x 43 x 1.5 PL	PLAST 12	
	Anillo A 30 x 35 x 1 PL	PLAST 1	
	Guarnición goma G 23 x 32 x 5	GS 6	
	Anillo de goma G 65 x 7	GS 1	
	Anillo de goma G 58 x 7	GS 1	
	Anillo de goma G 20 x 27 x 4	GS 9	
	Anillo G 20 x 28 x 13	GS 2	
	Anillo G 95 x 100 x 3.5	GS 1	
	Anillo G 21 x 28 x 3	GS 1	
	Anillo G 35 x 45 x 6.6	GS 4	
	Anillo G 34 x 39 x 3	GS 3	
	Anillo G 46 x 55 x 4.5	GS 3	
	Anillo G 25 x 29 x 3	GS 2	
	Anillo G 20 x 27.5 x 13	GS	
	Anillo G 28 x 34 x 3	GS	
	Anillo G 36 x 45 x 6	GS	
	Anillo G 50 x 56.5 x 4	GS 1	
	Anillo G 24 x 30 x 3	GS 2	
	O´ring G 34 x 3	GS 4	

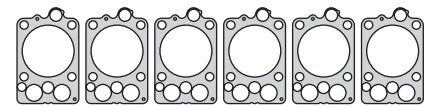

880108



880110



880112



880112

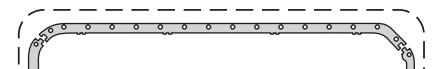

880013



880115



880117



880036



880039



810362

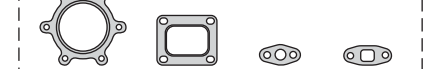

880263

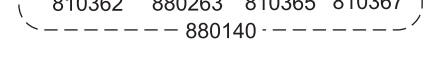

810365



810367



880140

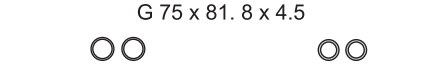

880044



880046



880146

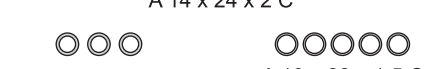

A 26.5 x 31.5 x 1.5 C



A 22 x 28.5 x 2 C

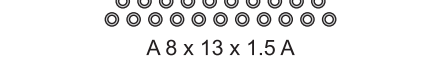

A 14 x 24 x 2 C



A 16 x 22 x 1.5 C



A 18 x 22 x 1.5 C

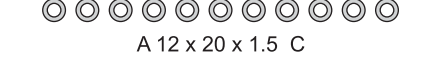

A 8 x 13 x 1.5 A

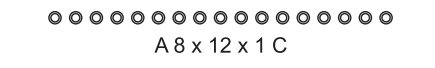

A 20 x 24 x 1.5 C

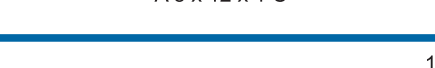

A 24 x 30 x 1.5 C



A 12 x 20 x 1.5 C

A 8 x 12 x 1 C

VOLVO



Motor/Engine	Cm³	HP	Ø
TD 100A	9600	230/260	120.6

Volvo: N10 1980/85



DIESEL

Nº OE	Descripción/Description	Mat.	Ref.
	Jgo. de juntas para motor		880200-R
275.551	Junta tapa cilindros Ø 130 \pm 1.40	ACG	6
423145.2	Junta tapa de válvulas	GS	6
424.607	Jgo. junta para cárter (4)	NB	1
467.177	Delantera de distribución	NB	1
468.557	Placa de distribución	NB	1
423.127	Bomba de agua	NB	1
	Jgo. múltiple escape (6)	NFT	1
422.616	Junta admisión	NFT	1
423146.2	Junta tapa de válvulas	GS	6
	Guarnición de goma grafitada	GFT	6
	Lateral tapa de válvulas	GS	3
	Guarnición goma (verde claro)	GS	6
	Kit de turbina (un agujero) (4)	VS	1
	Anillo fieltro	FIE	1
	Guarnición goma	GS	1
	Anillo G 18 x 23 x 3	GS	1
	Kit de arandelas (89)	VS	1
	Kit de gomas (91)	VS	1
	Turbina turbo	AC	1
	Escape turbo	AC	1
	Entrada de aceite a turbo	NB	1
	Entrada turbo	NB	1
	Anillo múltiple escape G 75 x 81.8 x 4.5	GS	6
	Arandela A 8 x 12 x 1 C	CU	1
	Arandela A 10 x 16.2 x 1.5 C	CU	5
	Arandela A 12 x 20 x 1.5 C	CU	9
	Arandela A 14 x 24 x 2 C	CU	16
	Arandela A 16.2 x 22.4 x 1.4 C	CU	4
	Arandela A 19 x 22.4 x 1.4 C	CU	2
	Arandela A 19 x 28.5 x 1.8 C	CU	2
	Arandela A 22.2 x 28.5 x 1.8 C	CU	2
	Arandela A 8 x 12.2 x 1.5 A	AL	15
	Arandela A 8.2 x 13 x 1.5 A	AL	24
	Arandela A 22 x 27 x 1.5 A	AL	2
	Anillo de goma G 41 x 50 x 3	GS	2
	Anillo A 45 x 50 x 1.4 PL	PLAST	6
	Anillo A 38 x 43 x 1.5 PL	PLAST	12
	Anillo A 30 x 35 x 1 PL	PLAST	2
	Anillo G 116 x 3.5	GS	1
	Guarnición goma G 23 x 32 x 5	GS	6
	Anillo de goma G 22 x 28 x 3	GS	2
	Anillo de goma G 28 x 4	GS	6
	Anillo de goma G 65 x 7	GS	1
	Anillo de goma G 58 x 7	GS	1
	Anillo G 95 x 100 x 3.5	GS	1
	Anillo G 15 x 20 x 3	GS	6
	Anillo G 71 x 78 x 4	GS	
	Anillo G 28 x 34 x 4.6	GS	1
	O´ring G 55 x 3	GS	2
	O´ring G 22 x 3	GS	1
	O´ring G 19 x 3	GS	2
	O´ring G 65 x 3	GS	1

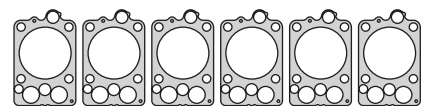

880108



880110



880131

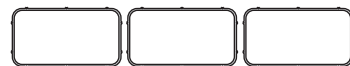

880036

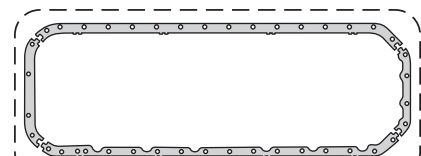

880214

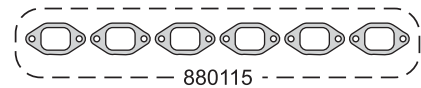

880115

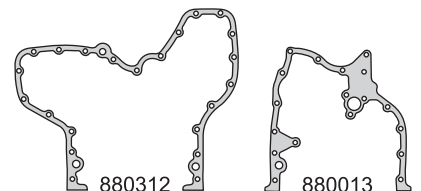

880312

880013



880214

880117

880233

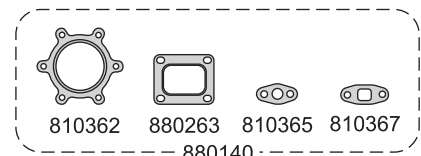

810362

880263

810365

810367

880140



880240

880046

880241



880039



G 75 x 81.8 x 4.5



A 16.2 x 22.4 x 1.4 C

A 19 x 22.4 x 1.4 C



A 14 x 24 x 2 C



A 22 x 27 x 1.5 A

A 22.2 x 28.5 x 1.8 C



A 8 x 12.2 x 1.5 A



A 19 x 28.5 x 1.8 C

A 10 x 16.2 x 1.5 C

VOLVO



Motor/Engine	Cm³	HP	Ø
TD 100G/101G 101F	9600	273/300	120.6

Volvo: N10 1985/89



DIESEL

Nº OE	Descripción/Description	Mat.	Ref.
	Jgo. de juntas para motor		880300-R
270.789	Junta tapa cilindros Ø 136.5 ± 1.40	ACG	6 880008
424693.0	Junta tapa válvulas superior	GS	6 880010
799.264	Jgo. junta para cárter (4)	NB	1 880311
468.116	Delantera de distribución	NB	880012
467.177	Delantera de distribución	NB	880312
468.557	Placa de distribución	NB	1 880013
	Bomba de agua	NB	1 880214
	Bomba de agua	NB	1 880314
479.107	Jgo. múltiple escape (6)	NFT	1 880015
424.618	Múltiple admisión	NFT	1 880017
423.352	Tapa bomba de agua	CB	1 880319
	Junta válvula termostato	CB	1 880431
424694.8	Tapa de válvulas inferior	GS	6 880031
	Guarnición goma grafitada	GFT	6 880233
	Lateral tapa de válvulas	GS	3 880036
	Guarnición goma (verde claro)	GS	6 880039
	Kit de turbina (bipartida) (4)	VS	1 880040
	Anillo fieltro	FIE	1 880240
	Guarnición goma	GS	1 880241
	Pico metálico	AC	1 880342
	Kit de arandelas (84)	VS	1 880347
	Kit de gomas (96)	VS	1 880348
	Turbina turbo	AC	1 810362
	Base turbo	AC	1 810363
	Entrada de aceite a turbo	NB	1 810365
	Entrada turbo	NB	1 810367
	Anillo múltiple de escape G 75 x 81 x 4.5	GS	6
	Arandela A 8 x 12 x 1 C	CU	16
	Arandela A 10 x 16 x 1.5 C	CU	5
	Arandela A 12 x 20 x 1.5 C	CU	9
	Arandela A 14 x 24 x 2 C	CU	18
	Arandela A 16 x 20 x 1.5 C	CU	4
	Arandela A 18 x 22 x 1.5 C	CU	4
	Arandela A 19 x 27 x 2 C	CU	2
	Arandela A 22 x 28 x 1.5 A	AL	2
	Arandela A 24.4 x 31 x 1.8 C	CU	
	Arandela A 10 x 14.5 x 1.5 A	AL	
	Arandela A 22 x 27 x 1.5 A	AL	
	Arandela A 8 x 15 x 1.5 C	CU	24
	Anillo de goma G 41 x 50 x 3	GS	1
	Anillo A 45 x 50 x 1.4 PL	PLAST	6
	Anillo A 38 x 43 x 1.5 PL	PLAST	12
	Anillo A 30 x 35 x 1 PL	PLAST	2
	Anillo G 116 x 3.5	GS	1
	Guarnición goma G 23 x 32 x 5	GS	6
	Guarnición goma G 22 x 28 x 3	GS	2
	Guarnición goma G 19 x 28 x 7	GS	1
	Guarnición goma G 58 x 7	GS	1
	Guarnición goma G 65 x 7	GS	1
	Anillo G 95 x 100 x 3.5	GS	1
	Anillo G 15 x 20 x 3	GS	6
	Anillo G 24 x 32 x 5	GS	2

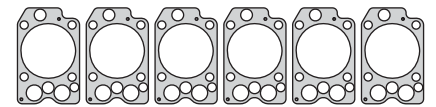

880008

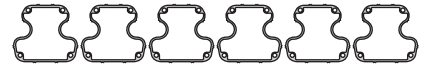

880010



880311



880012

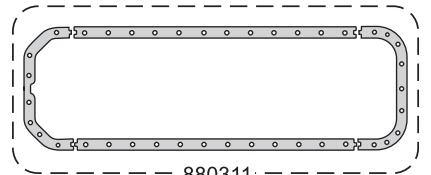

880312

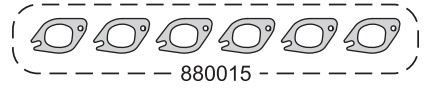

880013

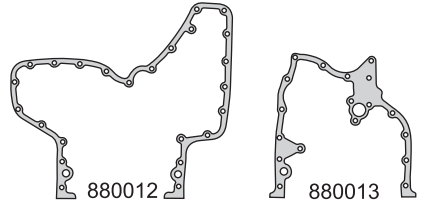

880015

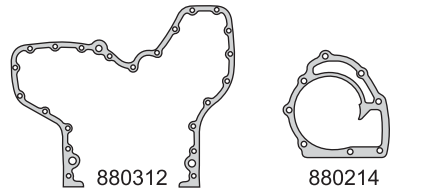

880314

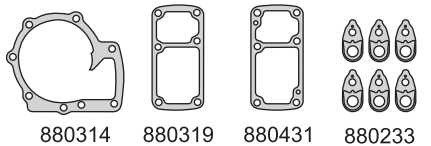

880431

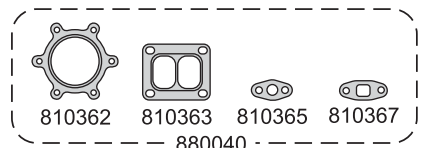

810362



810363



810365



810367



880040



880017



880039

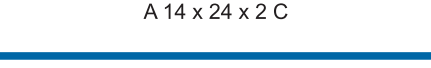

880240



880241

880342

G 56 x 3.4

G 75 x 81 x 4.5

A 16 x 20 x 1.5 C

A 10 x 16 x 1.5 C

A 14 x 24 x 2 C

VOLVO



Motor/Engine Cm³ HP Ø

TD 100G/101G 101F 9600 273/300 120.6

Volvo: N10 1985/89

DIESEL



Nº OE	Descripción/Description	Mat.	Ref.
	Anillo G 28 x 34 x 4.6	GS 1	
	Anillo G 25 x 29 x 3	GS 1	
	Anillo G 23 x 28 x 5	GS 2	
	Anillo G 18 x 28 x 7	GS 1	
	Anillo G 41 x 57 x 3	GS 1	
	Anillo G 71 x 78 x 4	GS 1	
	O´ring G 86 x 3	GS 1	
	O´ring G 55 x 3	GS 1	
	O´ring G 60 x 3	GS 2	
	O´ring G 34 x 3	GS 3	
	O´ring G 24 x 2.5	GS 1	
	O´ring G 64 x 3	GS 1	
	O´ring G 56 x 3.4	GS	
	Kit de retenes completo		R880000
	Retén bancada 155 x 180 x 15	V 1	R880011V
	Retén distribución 85.72 x 114.33 x 13	V 1	R880012V
	Retén árbol de levas 30 x 50 x 7.5	V 1	R340312V

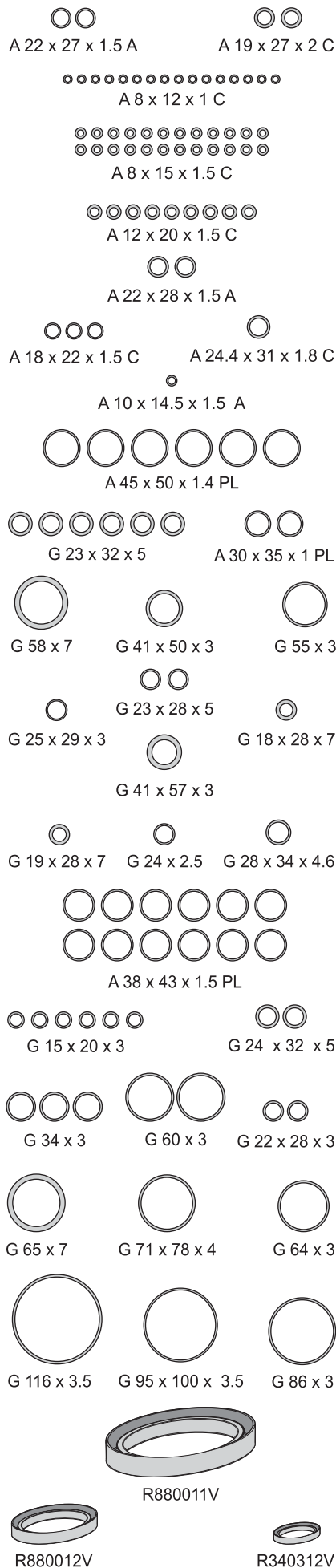

VOLVO



Motor/Engine	Cm³	HP	Ø
TD 121G/120GA 121F	11950 11950	295/360 328/385	130.2 130.2

Volvo: N12 1980/89



DIESEL

Nº OE	Descripción/Description	Mat.	Ref.
	Jgo. de juntas para motor		880400-R
270.548	Junta tapa cilindros Ø 147.5 ± 1.40	ACG 6	880308
	Jgo. tornillos tapa cilindros (HAS21038)		B880400
424692.2	Junta tapa válvulas	GS 6	880410
478.505	Jgo. junta para cárter (4)	NB 1	880411
468.116	Delantera de distribución	NB 1	880012
468.557	Placa de distribución	NB 1	880013
	Bomba de agua	NB 1	880314
479.107	Jgo. múltiple escape (6)	NFT 1	880015
422.616	Junta admisión	NFT 1	880117
423.352	Tapa bomba de agua	CB 1	880319
	Junta válvula termostato	CB 1	880419
1545244	Junta válvula termostato	CB 2	880431
	Lateral tapa de válvulas	GS 3	880036
	Guarnición goma (verde claro)	GS 6	880039
	Kit de turbina (un agujero) (4)	VS	880140
	Anillo de fieltro	FIE 1	880240
	Guarnición goma	GS 1	880741
	Anillo G 18 x 23 x 3	GS 2	880046
	Kit de arandelas (72)	VS 1	880447
	Kit de gomas (87)	VS 1	880448
	Turbina turbo	AC 1	810362
	Junta salida escape a turbo	AC	880263
	Entrada de aceite a turbo	NB 1	810365
	Entrada turbo	NB 1	810367
	Anillo múltiple de escape G 79 x 86 x 4.5	GS 6	
	Arandela A 8 x 12 x 1 C	CU 15	
	Arandela A 10 x 16 x 1.5 C	CU 5	
	Arandela A 12 x 20 x 1.5 C	CU 4	
	Arandela A 14 x 24 x 2 C	CU 21	
	Arandela A 16 x 22 x 1.5 C	CU 1	
	Arandela A 18 x 22 x 1.5 C	CU 2	
	Arandela A 20 x 24 x 1.5 C	CU 1	
	Arandela A 22 x 28 x 1.5 C	CU 4	
	Arandela A 24 x 30 x 2 C	CU 1	
	Arandela A 8 x 12 x 1.5 A	AL 14	
	Arandela A 10 x 14 x 1.5 A	AL 2	
	Arandela A 22 x 27 x 1.5 A	AL 2	
	Anillo de goma G 41 x 50 x 3	GS 1	
	Anillo A 30 x 35 x 1 PL	PLAST	
	Anillo A 45 x 50 x 1.5 PL	PLAST 6	
	Anillo A 38 x 43 x 1.4 PL	PLAST 12	
	Anillo G 116 x 3.5	GS 1	
	Guarnición goma G 23 x 32 x 5	GS 6	
	Anillo de goma G 22 x 28 x 3	GS 2	
	Anillo de goma G 19 x 28 x 7	GS 1	
	Anillo G 95 x 100 x 3.5	GS 1	
	Anillo G 15 x 20 x 3	GS 6	
	Anillo G 28 x 32 x 3.8	GS 6	
	Anillo G 24 x 32 x 5	GS 2	
	Anillo G 24 x 30 x 3	GS 2	
	Anillo G 71 x 78 x 4	GS 1	
	Anillo G 46 x 55 x 4.5	GS 1	

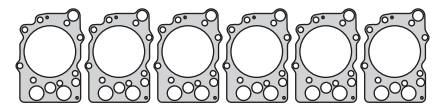

880308



880410



880036

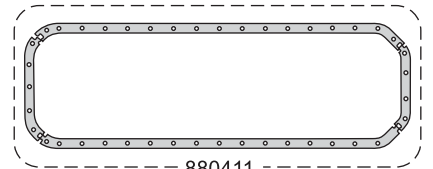

880411



880015

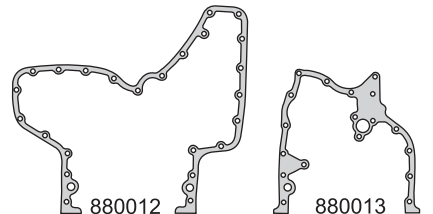

880012

880013

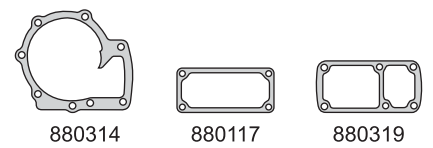

880314

880117

880319

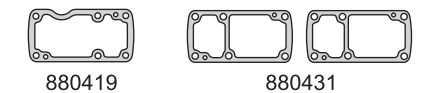

880419

880431

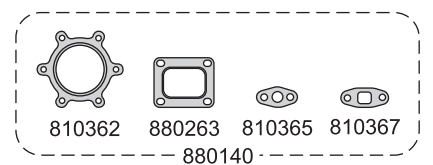

810362

880263

810365

810367

880140



880741

880039

880046



G 19 x 28 x 7

880240

G 22 x 28 x 3



G 79 x 86 x 4.5

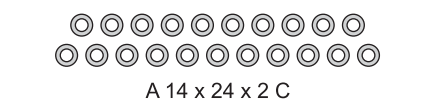

A 14 x 24 x 2 C



A 12 x 20 x 1.5 C

A 10 x 16 x 1.5 C

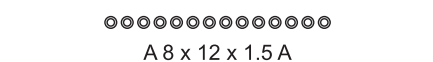

A 8 x 12 x 1.5 A



A 22 x 27 x 1.5 A

A 18 x 22 x 1.5 C

VOLVO



Motor/Engine	Cm³	HP	Ø
TD 121G/120GA 121F	11950 11950	295/360 328/385	130.2 130.2

Volvo: N12 1980/89

DIESEL



Nº OE	Descripción/Description	Mat.	Ref.
	Anillo G 28 x 34 x 4.6	GS 1	
	Anillo G 25 x 29 x 3	GS 1	
	Anillo G 41 x 57 x 3	GS 1	
	O´ring G 86 x 3	GS 1	
	O´ring G 55 x 3	GS 2	
	O´ring G 60 x 3	GS 1	
	O´ring G 22 x 3	GS 1	
	O´ring G 24 x 2.5	GS 2	
	O´ring G 19 x 3	GS 1	
	O´ring G 34 x 3	GS 3	
	Kit de retenes completo		R880000
	Retén bancada 155 x 180 x 15	V 1	R880011V
	Retén distribución 85.72 x 114.33 x 13	V 1	R880012V
	Retén árbol de levas 30 x 50 x 7.5	V 1	R340312V

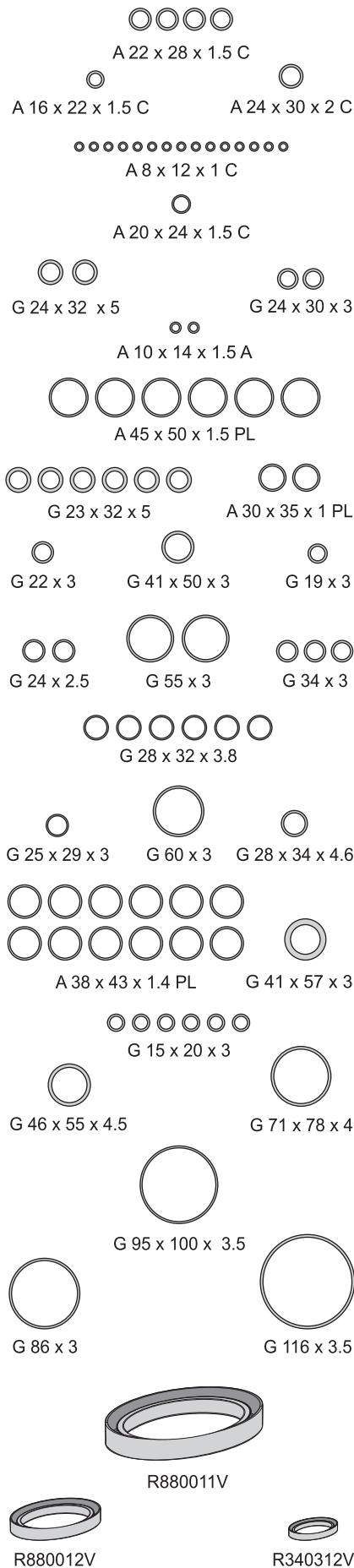

VOLVO



Motor/Engine	Cm³	HP	Ø
EDC	9600		120.6

Volvo: NL10 1998/...



DIESEL

Nº OE	Descripción/Description	Mat.	Ref.
	Jgo. de juntas para motor		880500-R
270.789	Junta tapa cilindros Ø 136.5 ± 1.40	ACG 6	880008
423145.2	Junta tapa válvulas	GS 6	880010
479.264	Jgo. junta para cárter (4)	NB 1	880311
468.116	Delantera de distribución	NB 1	880012
468.557	Placa de distribución	NB 1	880013
423.127	Bomba de agua	NB 1	880214
479.107	Jgo. múltiple escape (6)	NFT 1	880015
424.618	Junta admisión	NFT 1	880017
424694.8	Junta tapa de válvulas	GS 6	880031
	Guarnición goma grafitada	GFT 6	880233
	Lateral tapa de válvulas	GS 3	880036
	Guarnición goma (verde claro)	GS 6	880039
	Kit de turbina (Bipartida) (4)	VS 1	880040
	Guarnición goma	GS 1	880241
	Anillo G 16 x 22 x 3	GS 6	880542
	Kit de arandelas (85)	VS 1	880547
	Kit de borracha (89)	VS 1	880548
	Turbina turbo	AC 1	810362
	Base turbo	AC 1	810363
	Entrada de aceite a turbo	NB 1	810365
	Entrada turbo	NB 1	810367
	Anillo múltiple escape G 75 x 81.8 x 4.5	GS 6	
	Arandela A 8 x 12 x 1 C	CU 27	
	Arandela A 10 x 16 x 1 C	CU 1	
	Arandela A 10 x 16 x 1.5 C	CU 1	
	Arandela A 12 x 20 x 1.5 C	CU 6	
	Arandela A 14 x 24 x 2 C	CU 20	
	Arandela A 16 x 22 x 1.5 C	CU 1	
	Arandela A 18 x 22 x 1.5 C	CU	
	Arandela A 18 x 27 x 2 A	AL 2	
	Arandela A 20 x 24 x 1.5 C	CU 1	
	Arandela A 22 x 28 x 2 C	CU	
	Arandela A 24 x 31 x 1.8 C	CU	
	Arandela A 22 x 27 x 1.5 A	AL 2	
	Arandela A 8 x 15 x 1.5 C	CU 24	
	Anillo de goma G 41 x 50 x 3	GS 1	
	Anillo A 45 x 50 x 1.4 PL	PLAST 6	
	Anillo A 38 x 43 x 1.5 PL	PLAST 12	
	Anillo A 30 x 35 x 1 PL	PLAST 1	
	Anillo G 116 x 3.5	GS 1	
	Guarnición goma G 23 x 32 x 5	GS 6	
	Anillo de goma G 22 x 28 x 3	GS 2	
	Anillo de goma G 19 x 28 x 7	GS 1	
	Anillo G 95 x 100 x 3.5	GS 1	
	Anillo G 15 x 20 x 3	GS 6	
	Anillo G 24 x 32 x 5	GS 2	
	Anillo G 71 x 78 x 4	GS 1	
	Anillo G 28 x 34 x 4.6	GS 1	
	Anillo G 25 x 29 x 3	GS 1	
	Anillo G 41 x 57 x 3	GS 1	
	O´ring G 86 x 3	GS 1	
	O´ring G 55 x 3	GS 2	

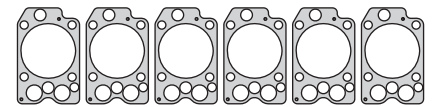

880008

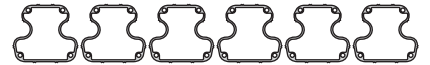

880010

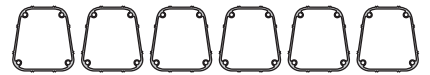

880031



880036

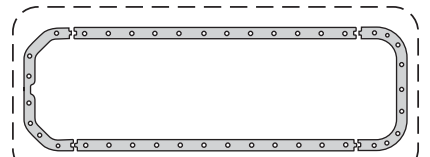

880031



880015

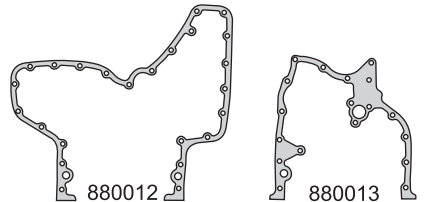

880012

880013

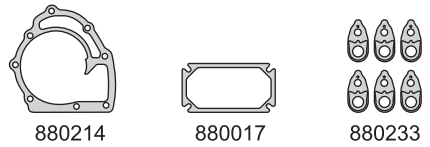

880214

880017

880233

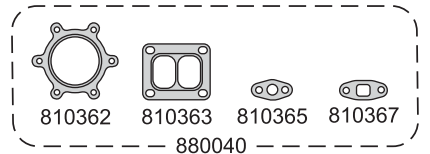

810362

810363

810365

810367

880040



880542

880039



880241

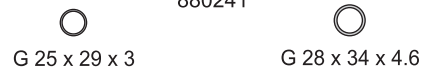

G 25 x 29 x 3

G 28 x 34 x 4.6



G 75 x 81.8 x 4.5



A 22 x 28.5 x 2 C

A 24 x 31 x 1.8 C



A 14 x 24 x 2 C



A 22 x 27 x 1.5 A

A 18 x 27 x 2 A



A 8 x 15 x 1.5 C

VOLVO**taranto**

Motor/Engine	Cm³	HP	Ø
TD 102F/102FS	9600	234/317	120.6

Volvo: NL10 1989/97

DIESEL



Nº OE	Descripción/Description	Mat.	Ref.
	Jgo. de juntas para motor		880600-R
270.789	Junta tapa cilindros Ø 136.5 ± 1.40	ACG 6	880008
424693.0	Junta tapa válvulas	GS 6	880010
479.264	Jgo. junta para cárter (4)	NB 1	880311
468.116	Delantera de distribución	NB 1	880012
468.557	Placa de distribución	NB 1	880013
423.127	Bomba de agua	NB 1	880214
479.107	Jgo. múltiple escape (6)	NFT 1	880015
424.618	Junta admisión	NFT 1	880017
424694.8	Junta tapa de válvulas	GS 6	880031
	Guarnición goma grafitada	GFT 6	880233
	Lateral tapa de válvulas	GS 3	880036
	Guarnición goma (verde claro)	GS 6	880639
	Kit turbina (Bipartida) (4)	VS 1	880040
	Guarnición goma	GS 1	880241
	Pico metálico	AL 1	880342
	Anillo G 76 x 82 x 4.5	GS 1	880742
	Anillo G 18 x 23 x 3	GS 1	880046
	Kit de arandelas (101)	VS 1	880647
	Kit de gomas (88)	VS 1	880648
	Turbina turbo	AC 1	810362
	Base turbo	AC 1	810363
	Entrada aceite a turbo	NB 1	810365
	Entrada turbo	NB 1	810367
	Anillo múltiple de escape G 75 x 81.8 x 4.5	GS 6	
	Arandela A 8 x 12 x 1 C	CU 28	
	Arandela A 10 x 16 x 1.5 C	CU 6	
	Arandela A 12 x 20 x 1.5 C	CU 5	
	Arandela A 14 x 24 x 2 C	CU 24	
	Arandela A 16 x 22 x 1.5 C	CU 2	
	Arandela A 18 x 22 x 1.5 C	CU 5	
	Arandela A 19 x 27 x 2 A	AL 2	
	Arandela A 20 x 24 x 1.5 C	CU	
	Arandela A 22 x 28 x 2 C	CU	
	Arandela A 24 x 30 x 1.5 C	CU 1	
	Arandela A 10 x 14 x 1.5 A	AL 2	
	Arandela A 22 x 26 x 1.5 C	CU 2	
	Arandela A 8 x 15 x 1.5 C	CU 24	
	Anillo de goma G 41 x 50 x 3	GS 1	
	Anillo A 45 x 50 x 1.5 PL	PLAST 6	
	Anillo A 30 x 35 x 1 PL	PLAST 2	
	Anillo A 38 x 43 x 1.4 PL	PLAST 12	
	Anillo G 116 x 3.5	GS 1	
	Guarnición goma G 23 x 32 x 5	GS 6	
	Anillo de goma G 22 x 28 x 3	GS 2	
	Anillo de goma G 19 x 28 x 7	GS 1	
	Anillo G 95 x 100 x 3.5	GS 1	
	Anillo G 15 x 20 x 3	GS 6	
	Anillo G 24 x 32 x 5	GS 2	
	Anillo G 28 x 34 x 4.6	GS 1	
	Anillo G 25 x 29 x 3	GS 1	
	Anillo G 41 x 57 x 3	GS 1	
	Anillo G 30 x 38 x 16.6	GS 1	

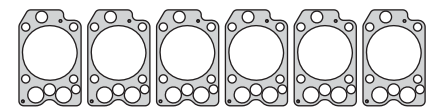

880008

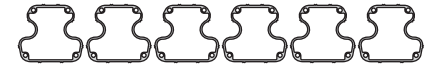

880010



880031



880036

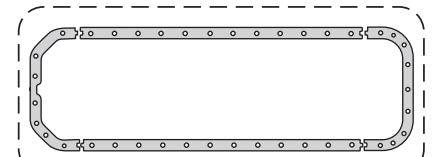

880311

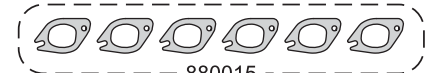

880015

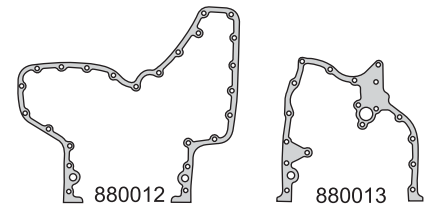

880012

880013

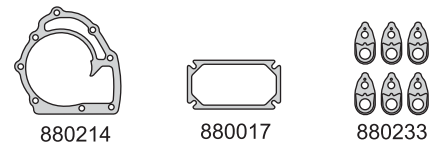

880214

880017

880233



880639

880241

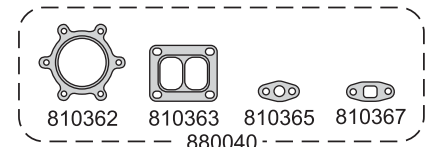

810362

810363

810365

810367

880040



880342

880742

880046



G 75 x 81.8 x 4.5



A 22 x 28 x 2 C



A 19 x 27 x 2 A



A 18 x 22 x 1.5 C



A 14 x 24 x 2 C



A 10 x 16 x 1.5 C



A 16 x 22 x 1.5 C



A 22 x 26 x 1.5 C

VOLVO



Motor/Engine	Cm³	HP	Ø
EDC	11950		120.6

Volvo: NL12 1997/...



DIESEL

Nº OE	Descripción/Description	Mat.	Ref.
	Jgo. de juntas para motor		880700-R
270.548	Junta tapa cilindros Ø 147.5 ± 1.40	ACG	6 880308
	Jgo. tornillos tapa cilindros (HAS21038)		B880400
424692.2	Junta tapa de válvulas	GS	6 880410
478.505	Jgo. junta para cárter (4)	NB	1 880411
468.116	Delantera distribución	NB	1 880012
468.557	Placa de distribución	NB	1 880013
	Bomba de agua	NB	1 880314
479.107	Jgo. múltiple escape (6)	NFT	1 880015
424.618	Junta admisión	NFT	1 880017
	Junta válvula termostato	CB	1 880419
	Lateral tapa de válvulas	GS	3 880036
	Guarnición goma (verde claro)	GS	6 880039
	Kit de turbina (un agujero) (4)	VS	880140
	Guarnición goma	GS	1 880741
	Anillo G 16 x 22 x 3	GS	880542
	Kit de arandelas (70)	VS	1 880747
	Kit de gomas (82)	VS	1 880748
	Turbina turbo	AC	1 810362
	Base turbo	AC	880263
	Entrada aceite a turbo	NB	1 810365
	Entrada turbo	NB	1 810367
	Anillo múltiple de escape G 79 x 86 x 4.5	GS	6
	Arandela A 8 x 12 x 1 C	CU	25
	Arandela A 10 x 16 x 1.5 C	CU	5
	Arandela A 12 x 20 x 1.5 C	CU	1
	Arandela A 14 x 24 x 2 C	CU	21
	Arandela A 16 x 22 x 1.5 C	CU	4
	Arandela A 18 x 22 x 1.5 C	CU	2
	Arandela A 19 x 27 x 2 C	CU	
	Arandela A 20 x 24 x 1.5 C	CU	2
	Arandela A 22 x 28 x 2 C	CU	2
	Arandela A 24 x 30 x 2 C	CU	2
	Arandela A 8 x 13 x 1.5 A	AL	
	Arandela A 10 x 14 x 1.5 A	AL	4
	Arandela A 22 x 27 x 1.5 A	AL	2
	Anillo de goma G 41 x 50 x 3	GS	1
	Anillo A 45 x 50 x 1.4 PL	PLAST	6
	Anillo A 38 x 43 x 1.5 PL	PLAST	12
	Anillo G 116 x 3.5	GS	1
	Guarnición goma G 26.5 x 32 x 3	GS	6
	Anillo de goma G 22 x 28 x 3	GS	2
	Anillo de goma G 19 x 28 x 7	GS	1
	Anillo G 95 x 100 x 3.5	GS	1
	Anillo G 15 x 20 x 3	GS	6
	Anillo G 28 x 32 x 3.8	GS	6
	Anillo G 24 x 32 x 5	GS	2
	Anillo G 24 x 30 x 3	GS	2
	Anillo G 71 x 78 x 4	GS	1
	Anillo G 28 x 34 x 4.6	GS	1
	Anillo G 25 x 29 x 3	GS	2
	Anillo G 41 x 57 x 3	GS	1
	O'ring G 86 x 3	GS	1

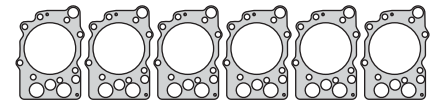

880308



880410



880036

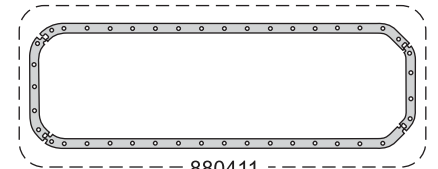

880411



880015

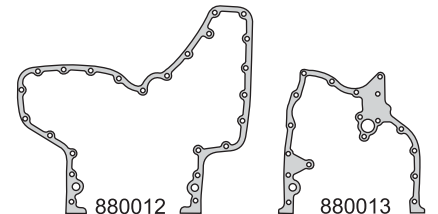

880012

880013

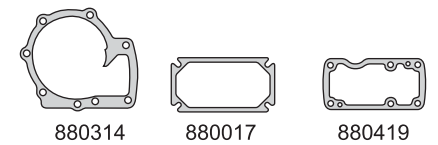

880314

880017

880419

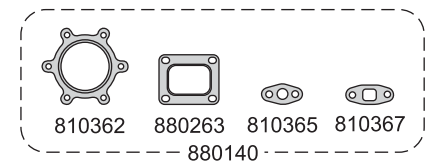

810362

880263

810365

810367

880140



880039

880741

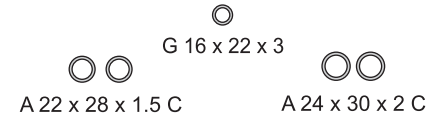

G 16 x 22 x 3

A 22 x 28 x 1.5 C

A 24 x 30 x 2 C



G 79 x 86 x 4.5



A 18 x 22 x 1.5 C

A 22 x 27 x 1.5 A

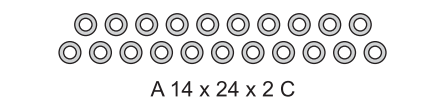

A 14 x 24 x 2 C



A 10 x 16 x 1.5 C

A 16 x 22 x 1.5 C

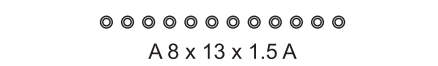

A 8 x 13 x 1.5 A



A 12 x 20 x 1.5 C

A 19 x 27 x 2 C

VOLVO



Motor/Engine	Cm³	HP	Ø
EDC	11950		120.6

Volvo: NL12 1997/...



DIESEL

Nº OE	Descripción/Description	Mat.	Ref.
	O´ring G 55 x 3	GS 1	
	O´ring G 22 x 3	GS 1	
	O´ring G 24 x 2.5	GS 1	
	O´ring G 65 x 3	GS 1	
	O´ring G 34 x 3	GS 3	
	O´ring G 21 x 3	GS 1	
	Kit de retenes completo		R880000
	Retén bancada 155 x 180 x 15	V 1	R880011V
	Retén distribución 85.72 x 114.33 x 13	V 1	R880012V
	Retén árbol de levas 30 x 50 x 7.5	V 1	R340312V

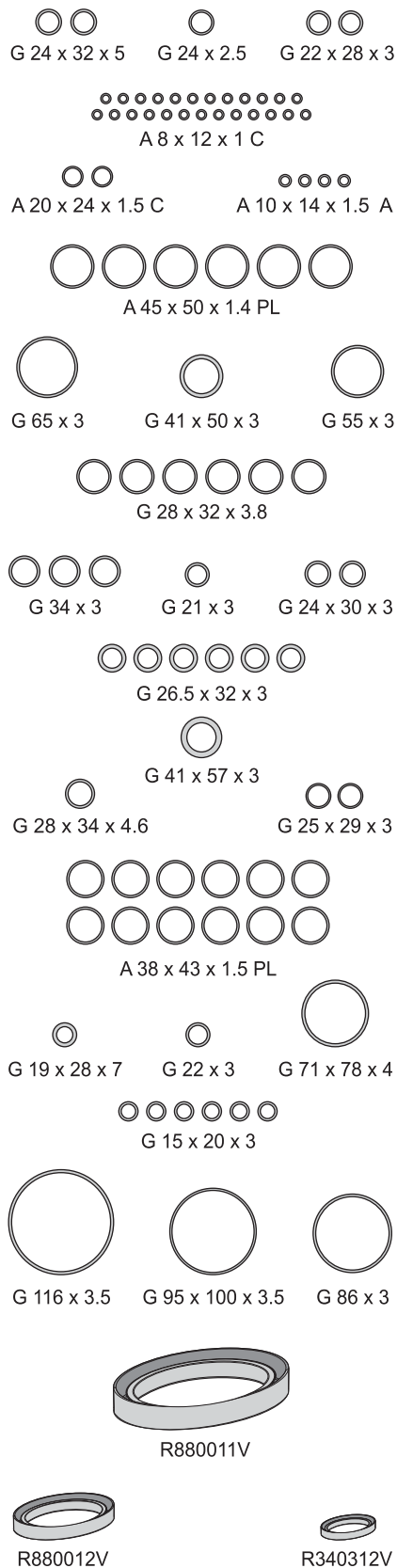

VOLVO**taranto**

Motor/Engine	Cm³	HP	Ø
TD 122FS	11950	396	130.2

Volvo: NL12 1989/96



DIESEL

Nº OE	Descripción/Description	Mat.	Ref.
	Jgo. de juntas para motor		880800-R
270.548	Junta tapa cilindros Ø 147.5 ± 1.40	ACG 6	880308
	Jgo. tornillos tapa cilindros (HAS21038)		B880400
424692.2	Junta tapa válvulas	GS 6	880410
478.505	Jgo. junta para cárter (4)	NB 1	880411
468.116	Delantera de distribución	NB 1	880012
468.557	Placa de distribución	NB 1	880013
	Bomba de agua	NB 1	880314
479.107	Jgo. múltiple escape (6)	NFT 1	880015
424.618	Junta admisión	NFT 1	880017
423.352	Junta válvula termostato	CB 1	880419
	Lateral tapa de válvulas	GS 3	880036
	Guarnición goma (verde claro)	GS 6	880039
	Kit de turbina (un agujero) (4)	VS	880140
	Anillo de fieltro	FIE 1	880240
	Guarnición goma	GS 1	880741
	Anillo G 16 x 22 x 3	GS 1	880542
	Kit de arandelas (74)	VS 1	880847
	Kit de gomas (93)	VS 1	880848
	Turbina turbo	AC 1	810362
	Base turbo	AC	880263
	Entrada aceite a turbo	NB 1	810365
	Entrada turbo	NB 1	810367
	Anillo múltiple de escape G 79 x 86 x 4.5	GS 6	
	Arandela A 8 x 12 x 1 C	CU 15	
	Arandela A 10 x 16 x 1.5 C	CU 5	
	Arandela A 12 x 20 x 1.5 C	CU 4	
	Arandela A 14 x 24 x 2 C	CU 21	
	Arandela A 16 x 22 x 1.5 C	CU 1	
	Arandela A 18 x 22 x 1.5 C	CU 2	
	Arandela A 19 x 27 x 2 A	AL 1	
	Arandela A 20 x 24 x 1.5 C	CU 1	
	Arandela A 22 x 28 x 1.5 C	CU 5	
	Arandela A 24 x 30 x 2 C	CU 1	
	Arandela A 8 x 12 x 1.5 A	AL 14	
	Arandela A 10 x 14 x 1.5 A	AL 2	
	Arandela A 22 x 27 x 1.5 A	AL 2	
	Anillo de goma G 41 x 50 x 3	GS	
	Anillo A 45 x 50 x 1.5 PL	PLAST 6	
	Anillo A 38 x 43 x 1.4 PL	PLAST 12	
	Anillo G 116 x 3.5	V 1	
	Guarnición goma G 23 x 32 x 5	GS 6	
	Anillo de goma G 22 x 28 x 3	GS 2	
	Anillo de goma G 19 x 28 x 7	GS 1	
	Anillo G 95 x 100 x 3.5	GS 1	
	Anillo G 15 x 20 x 3	GS 6	
	Anillo G 28 x 32 x 3.8	GS 6	
	Anillo G 24 x 32 x 5	GS 2	
	Anillo G 24 x 30 x 3	GS 2	
	Anillo G 71 x 78 x 4	GS 1	
	Anillo G 46 x 55 x 4.5	GS 1	
	Anillo G 28 x 34 x 4.6	GS 1	
	Anillo G 25 x 29 x 3	GS 1	

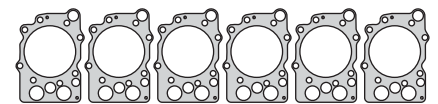

880308



880410



880036

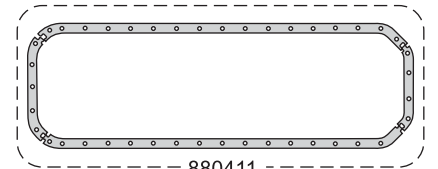

880411



880015

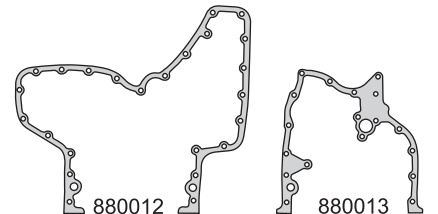

880012

880013

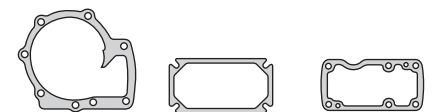

880314

880017

880419

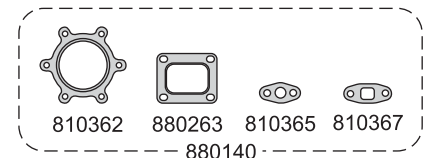

810362

880263

810365

810367

880140



880039

880741



880542

880240

G 22 x 3

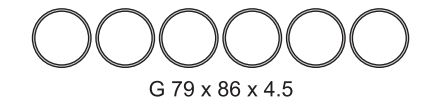

G 79 x 86 x 4.5



A 10 x 16 x 1.5 C

A 16 x 22 x 1.5 C

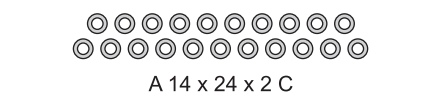

A 14 x 24 x 2 C

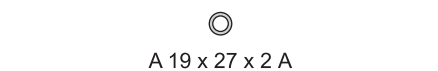

A 19 x 27 x 2 A



A 12 x 20 x 1.5 C

A 22 x 28 x 1.5 C



G 28 x 32 x 3.8

VOLVO



Motor/Engine	Cm³	HP	Ø
TD 122FS	11950	396	130.2

Volvo: NL12 1989/96

DIESEL



Nº OE	Descripción/Description	Mat.	Ref.
	Anillo G 41 x 57 x 3	GS	2
	Anillo G 12 x 20 x 5	GS	6
	O´ring G 86 x 3	GS	1
	O´ring G 55 x 3	GS	2
	O´ring G 60 x 3	GS	1
	O´ring G 34 x 3	GS	3
	O´ring G 22 x 3	GS	1
	O´ring G 24 x 2.5	GS	2
	O´ring G 19 x 3	GS	2
	Kit de retenes completo		R880000
	Retén bancada 155 x 180 x 15	V	1 R880011V
	Retén distribución 85.72 x 114.33 x 13	V	1 R880012V
	Retén árbol de levas 30 x 50 x 7.5	V	1 R340312V

